

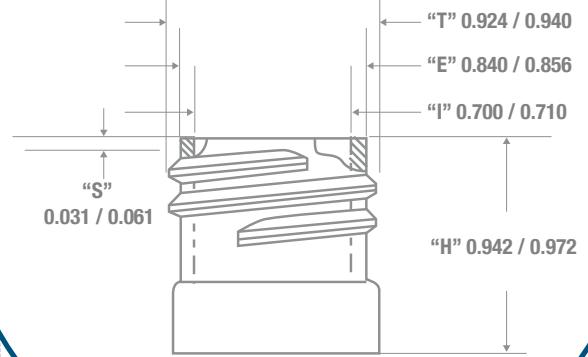

### NECK & THREAD DETAIL

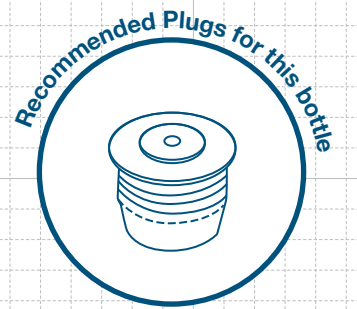

### FRONT VIEW

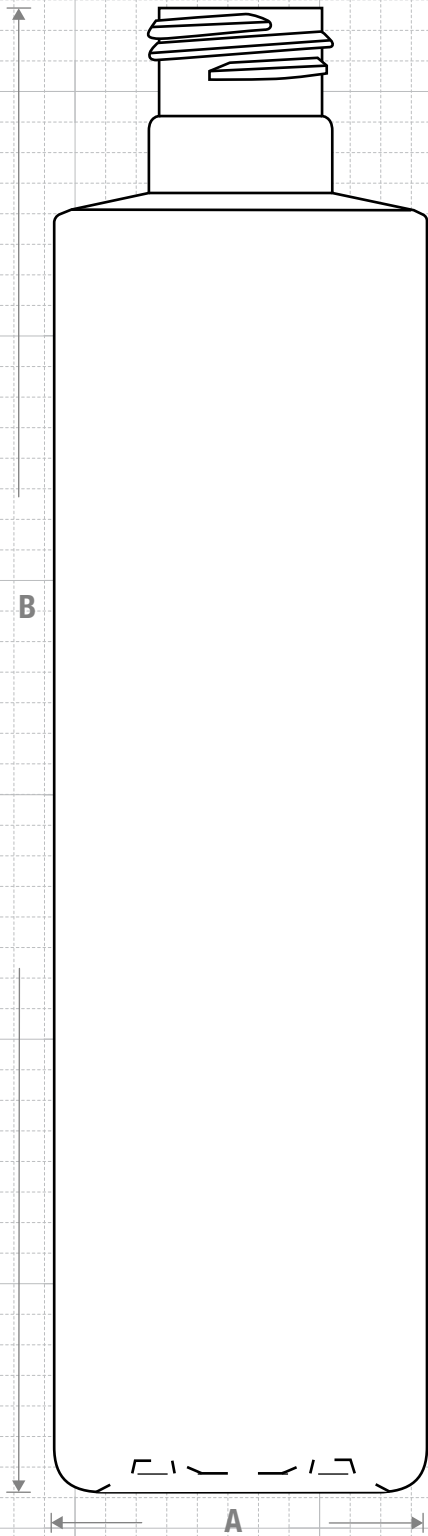

### FRICITION FIT

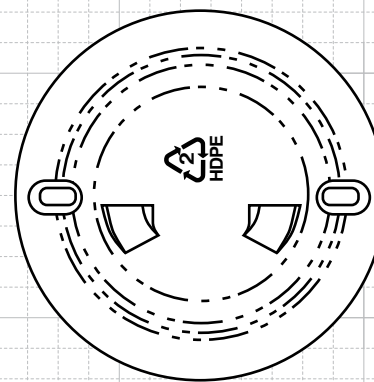

### BOTTOM VIEW



**CLASSIC CONTAINERS INC**  
 1700 S. Hellman Ave.  
 Ontario, CA 91761  
 Phone: 909-930-3610  
 e-mail: info@classiccontainers.com  
 www.classiccontainers.com

Drawing:  
**9 oz Sleek Cylinder 24/415**

Gram Weight:  
**30.0 ± 2**

Max Print Area (Height):  
**6.000"**

Cases Per Pallet: **16**

Stock Code:  
**000900490250000**

Neck Finish:  
**24/415**

Max Print Area (Width):  
**5.750"**

Box Dimensions:  
**24 7/16 x 18 1/2 x 23**

Manufacturing Process:  
**Extrusion Blow Molding**

Base Width (A):  
**1.925± 0.050**

Case Pack: **396**

Stock Material:



Overflow Capacity:  
**283 -301 ml (9.6 - 10.2 oz)**

Overall Height (B):  
**7.710 ± 0.050**

Case Weight (lb): **29.0 ± 1.7**

Rev #3 06/2016

Drawing not exactly to size.

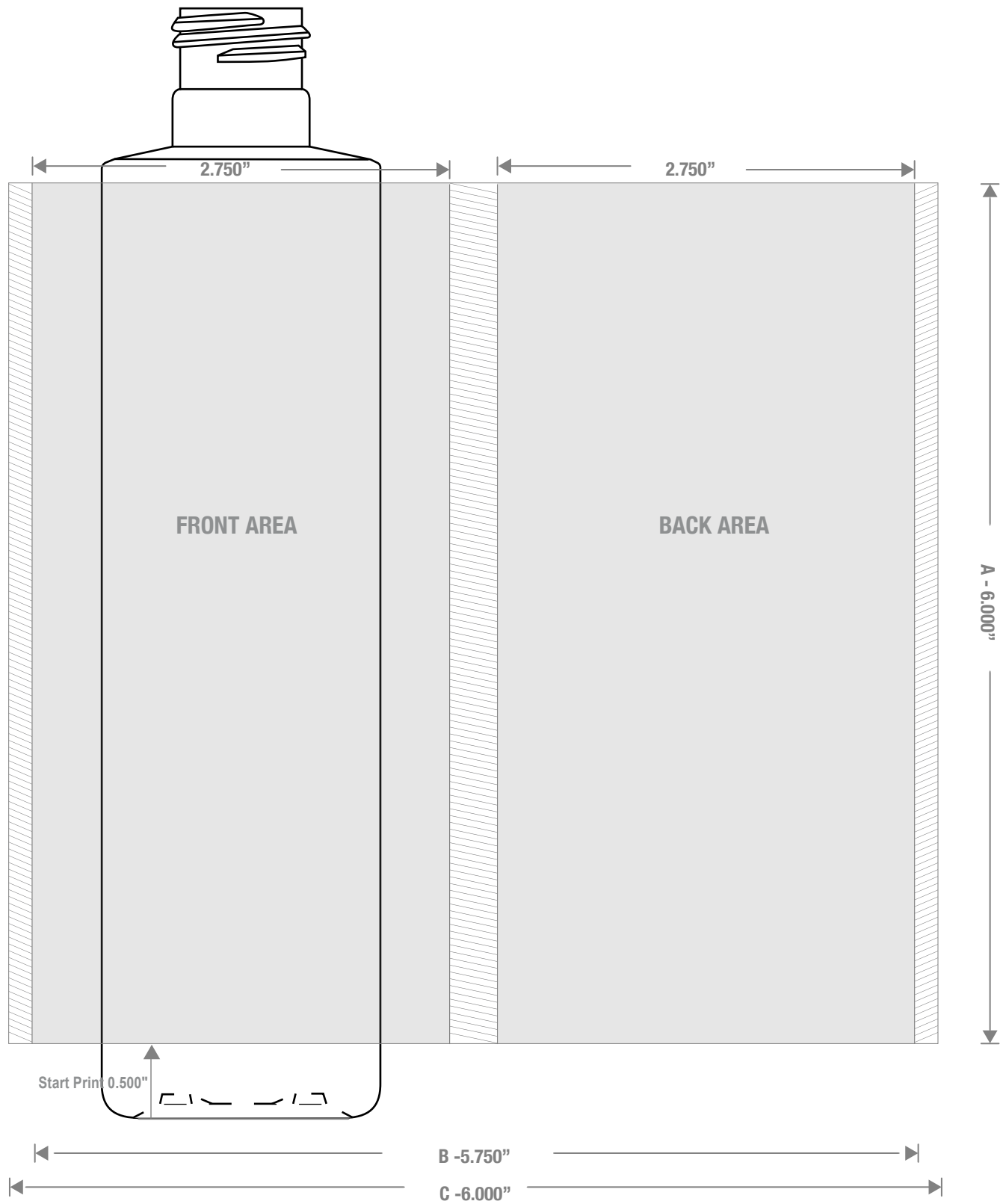

# LABELING SPECIFICATIONS (WRAP LABEL): 9 OZ SLEEK CYLINDER 24/415

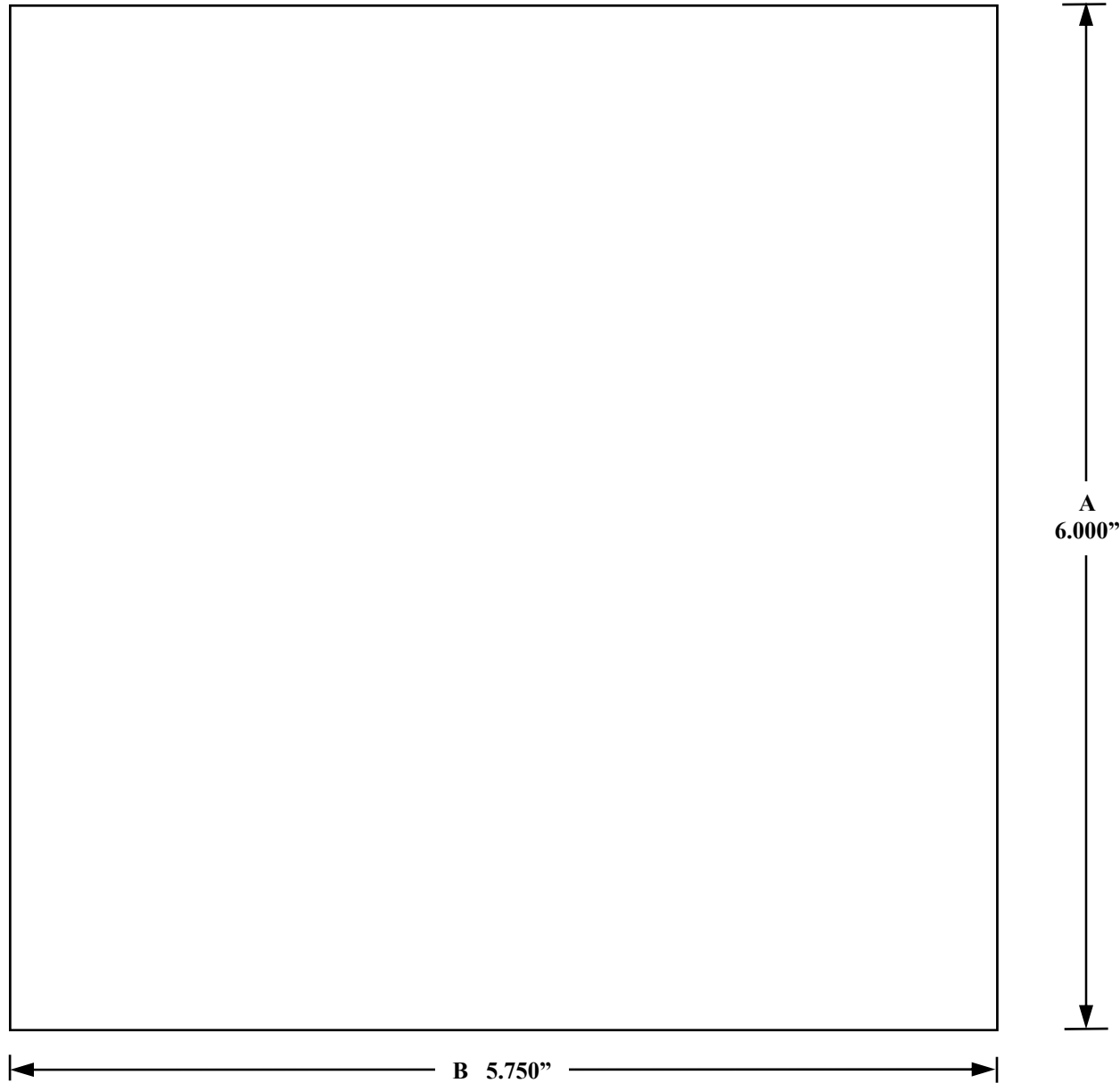

10/19/21



1700 S Hellman Ave, Ontario, California 91761  
Phone: (909) 930-3610 | Fax: (909) 930-3640  
e-mail: [info@classiccontainers.com](mailto:info@classiccontainers.com)  
[www.classiccontainers.com](http://www.classiccontainers.com)

A - Total Height.  
B - Max. Decorating Area.  
C - Total bottle circumference.  
☐ - Unprintable area.