

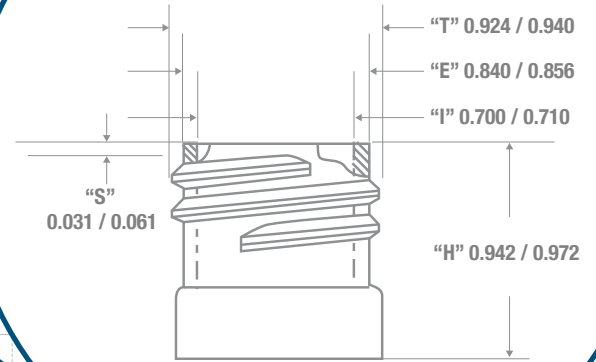

### NECK & THREAD DETAIL

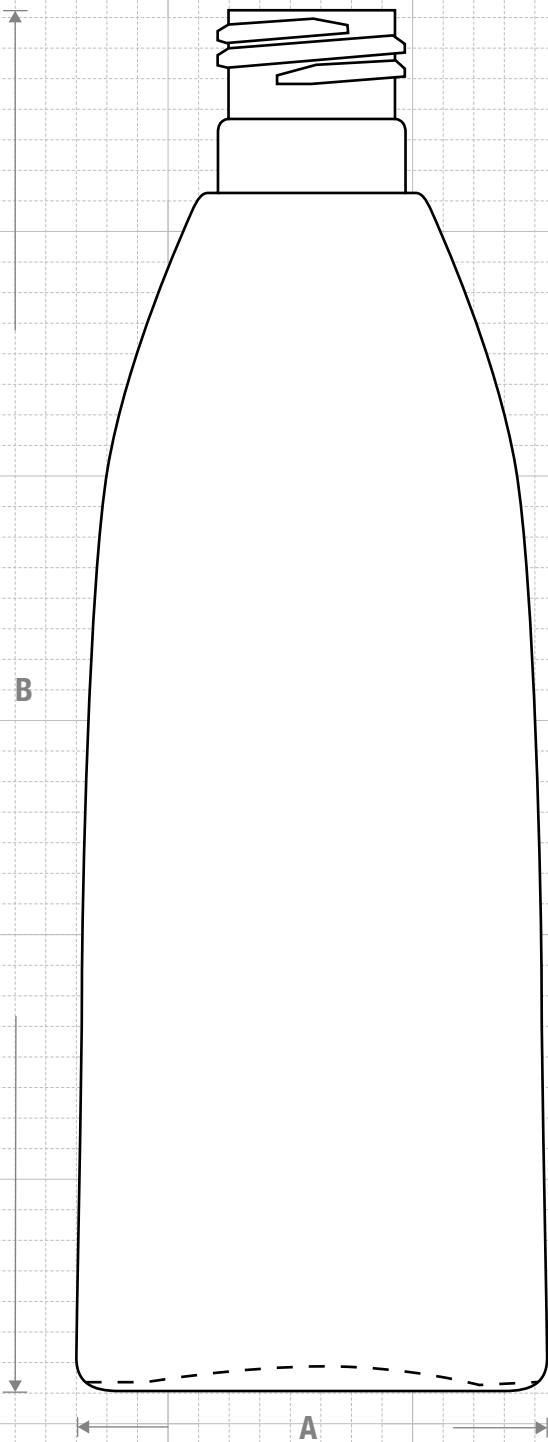

### FRONT VIEW



### SIDE VIEW

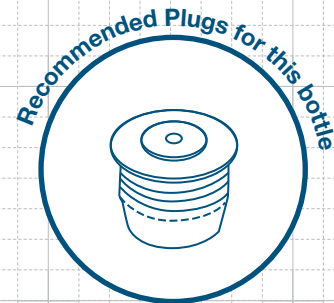
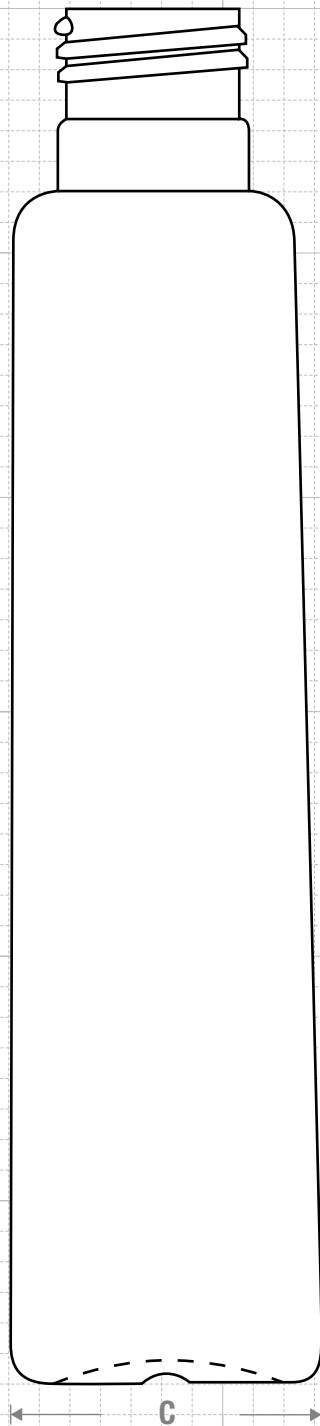

### FRICITION FIT

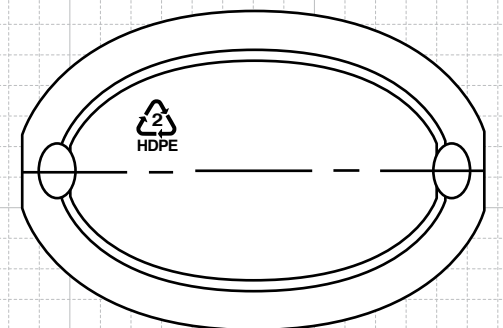

### BOTTOM VIEW



**CLASSIC CONTAINERS INC**  
 1700 S. Hellman Ave.  
 Ontario, CA 91761  
 Phone: 909-930-3610  
 e-mail: info@classiccontainers.com  
 www.classiccontainers.com

Drawing:  
**8 oz Teardrop 24/415**

Gram Weight:  
**24.5 ± 2**

Max Print Area (Height):  
**4.900"**

Cases Per Pallet: **16**

Stock Code:  
**000800350250000**

Neck Finish:  
**24/415**

Max Print Area (Width):  
 Shoulder: **1.000"** Base: **1.650"**

Box Dimensions:  
**24 7/16 x 18 1/2 x 23**

Manufacturing Process:  
**Extrusion Blow Molding**

Base Width (A) Base Deep (C):  
**2.489± 0.050 1.615± 0.050**

Case Pack: **378**

Stock Material:



Overflow Capacity:  
**251- 269 ml (8.5 - 9.1 oz)**

Overall Height (B):  
**7.202 ± 0.050**

Case Weight (lb): **23.3 ± 1.7**

Rev #3 06/2016

Drawing not exactly to size.

