



Drawing:
**8 oz Royalty Round 24/410
w/ Ring M-2**

Stock Code:
0008000424R00M2

Manufacturing Process:
Extrusion Blow Molding

Overflow Capacity:
257 - 274 ml (8.7 - 9.3 oz)

Gram Weight:
22 ± 2

Neck Finish:
24/410 W/R

Base Width (A):
2.025 ± 0.050

Overall Height (B):
6.430 ± 0.050

Max Print Area (Height):
4.375"

Max Print Area (Width):
6.125"

Case Pack: **414**

Case Weight (lb): **23.0 ± 1.8**

Cases Per Pallet: **16**

Box Dimensions:
24 7/16 x 18 1/2 x 23

Stock Material:



CLASSIC CONTAINERS INC
1700 S. Hellman Ave.
Ontario, CA 91761
Phone: 909-930-3610
e-mail: info@classiccontainers.com
www.classiccontainers.com

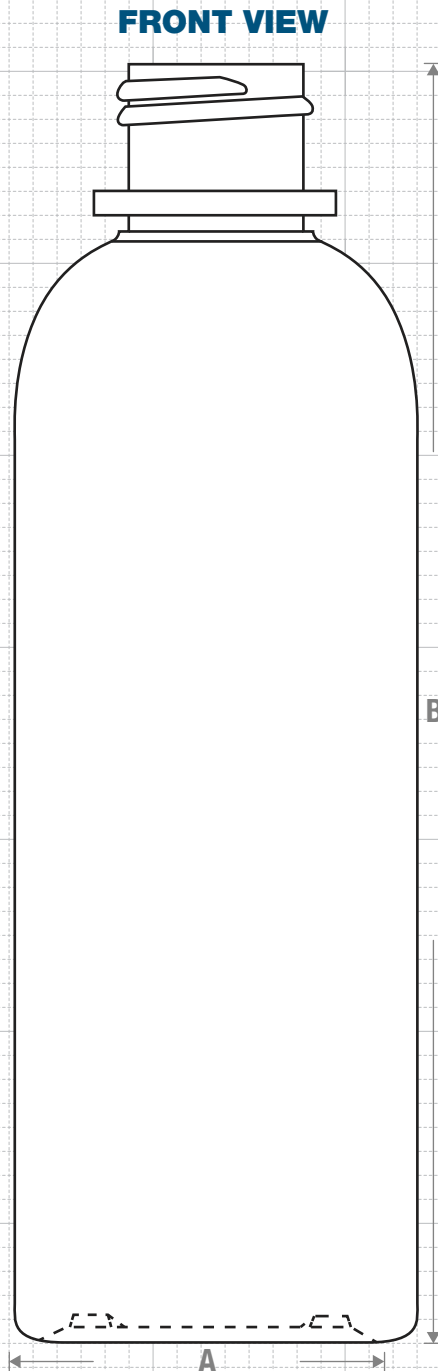

FRONT VIEW

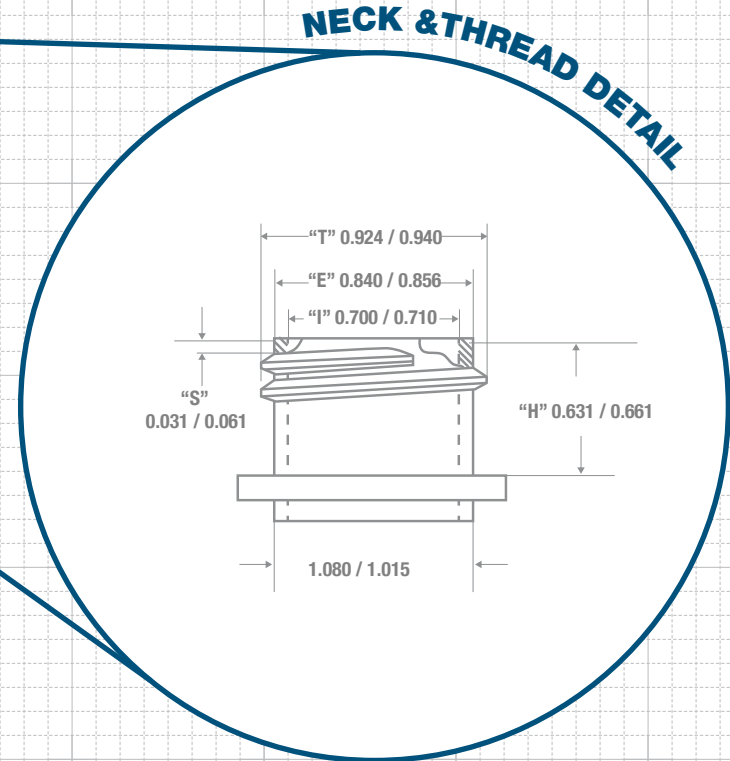
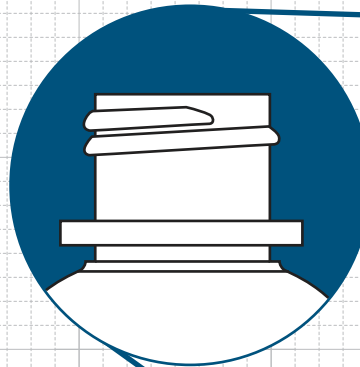

NECK & THREAD DETAIL

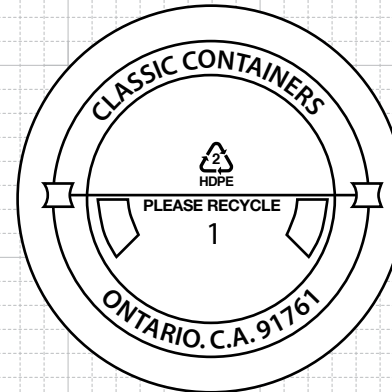

BOTTOM VIEW

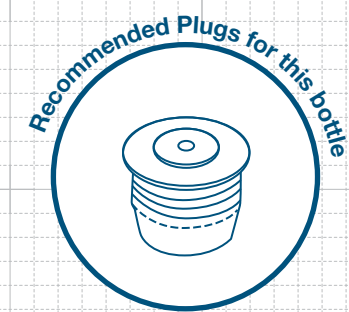

FRICITION FIT



PRINTING SPECIFICATIONS: 8 oz Royalty Round 24/410 W/Ring M2

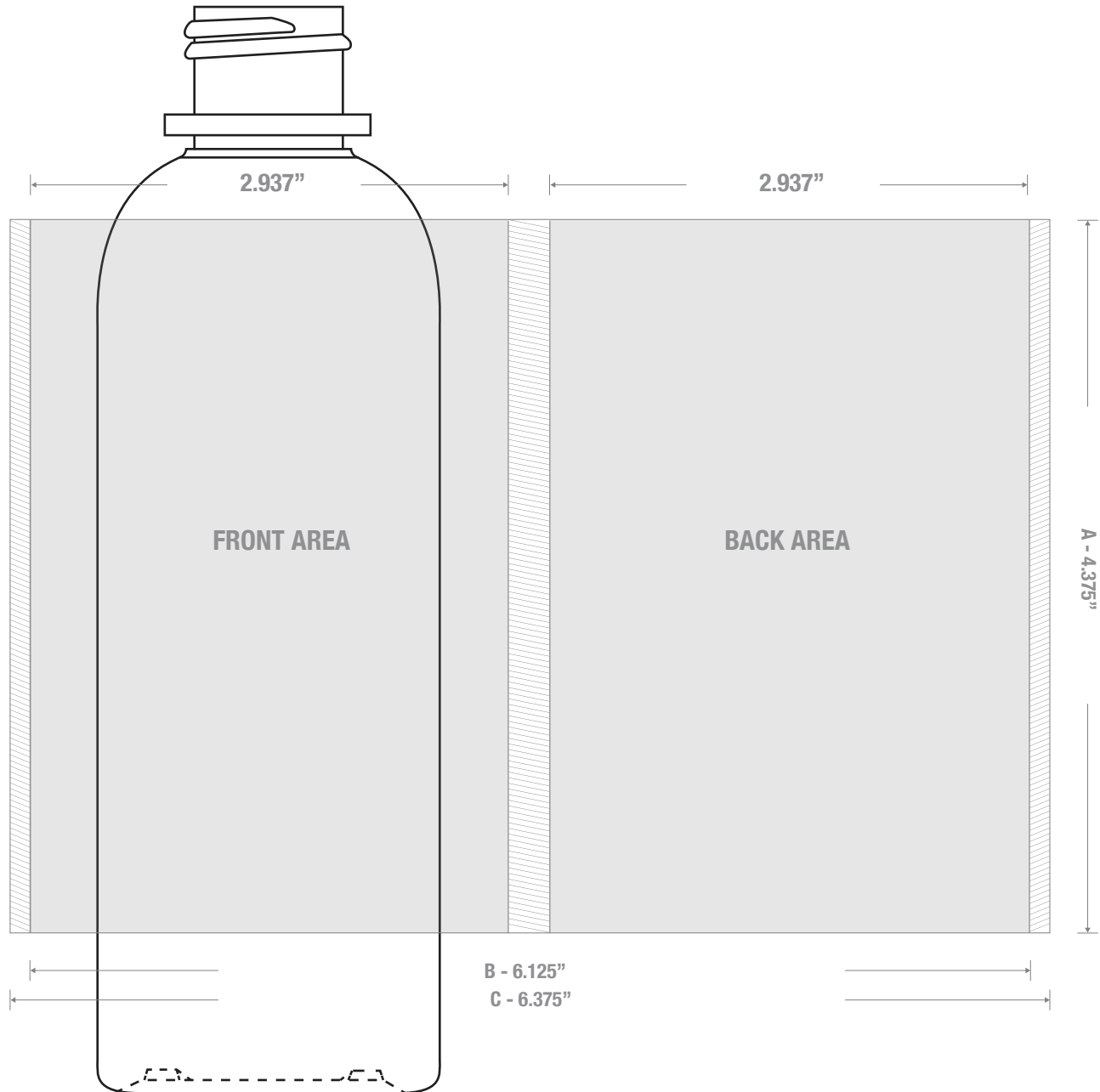

1700 S Hellman Ave, Ontario, California 91761
Phone: (909) 930-3610 | Fax: (909) 930-3640
e-mail: info@classiccontainers.com
www.classiccontainers.com

A - Total Height.
B - Max. Decorating Area.
C - Total bottle circumference.
▨ - Unprintable area.

LABELING SPECIFICATIONS: 8 oz Royalty Round 24/410 W/Ring M2

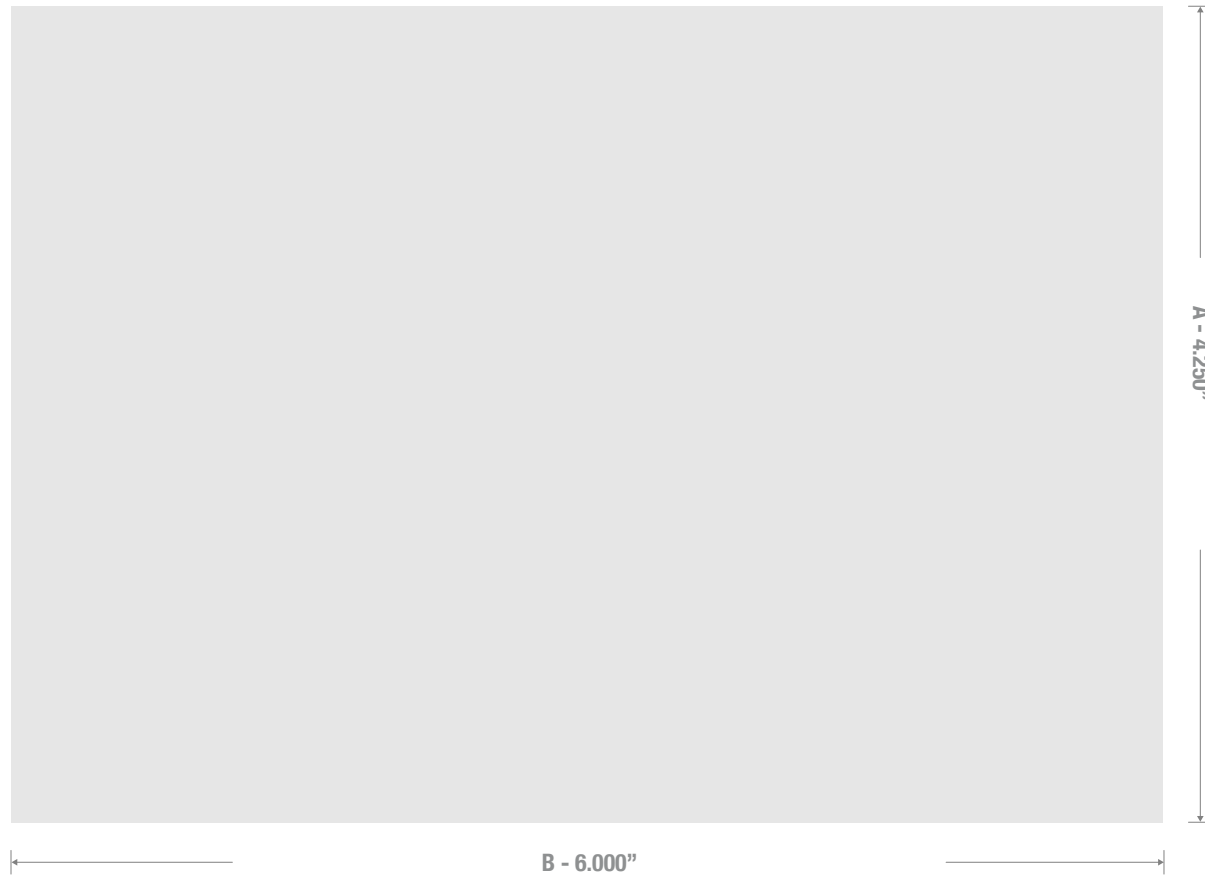

1700 S Hellman Ave, Ontario, California 91761
Phone: (909) 930-3610 | Fax: (909) 930-3640
e-mail: info@classiccontainers.com
www.classiccontainers.com

A - Total Height.
B - Total bottle circumference.