

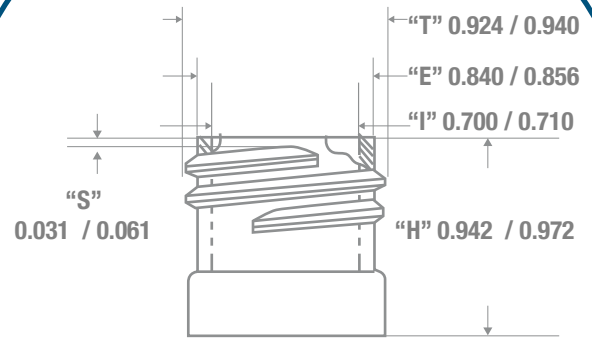

NECK & THREAD DETAIL

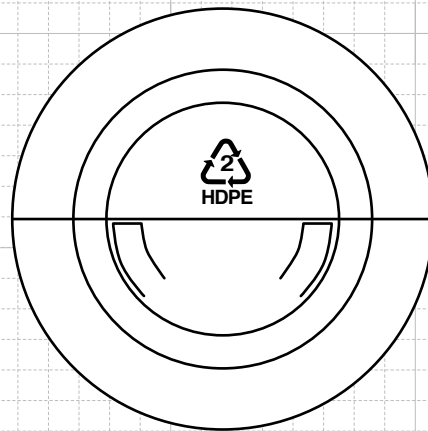

FRONT VIEW

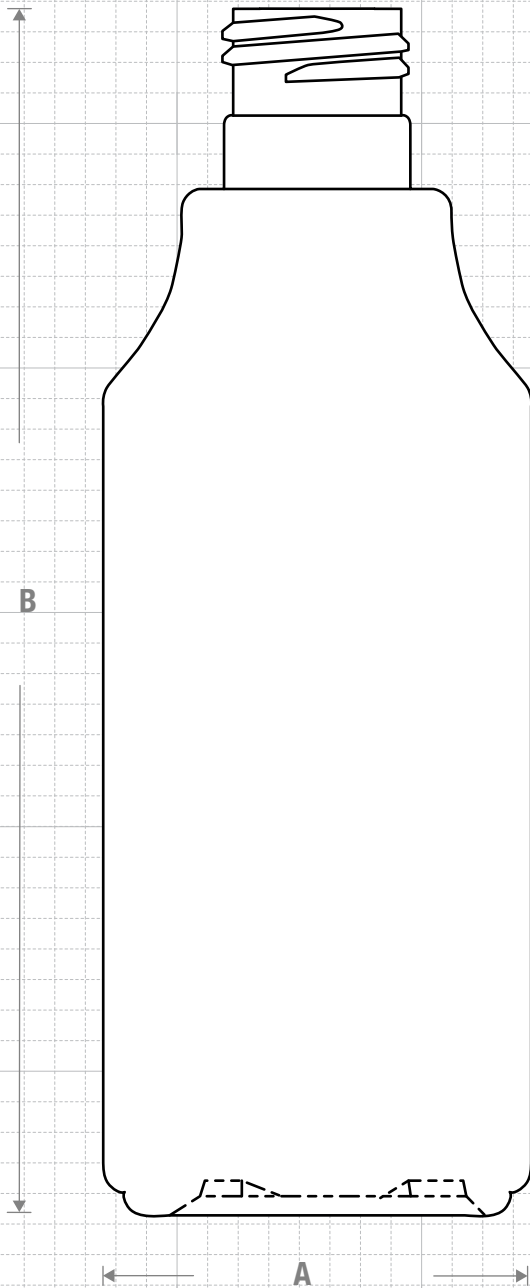

BOTTOM VIEW

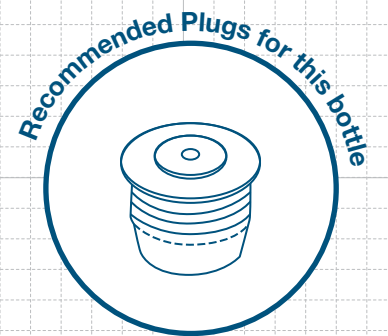

FRICTION FIT



CLASSIC CONTAINERS INC
 1700 S. Hellman Ave.
 Ontario, CA 91761
 Phone: 909-930-3610
 e-mail: info@classiccontainers.com
 www.classiccontainers.com

Drawing:
8 oz Queen Round 24/415

Stock Code:
000801260250000

Manufacturing Process:
Extrusion Blow Molding

Overflow Capacity:
271 - 289 ml (9.2 - 9.8 oz)

Gram Weight:
22 ± 2

Neck Finish:
24/415

Base Width (A):
2.200 ± 0.050

Overall Height (B):
6.277 ± 0.050

Max Print Area (Height):
3.625"

Max Print Area (Width):
6.687"

Case Pack: **378**

Case Weight (lb): **21.2 ± 1.7**

Cases Per Pallet: **16**

Box Dimensions:
24 7/16 x 18 1/2 x 23

Stock Material:



Rev #3 06/2016

Drawing not exactly to size.

