



Drawing:
8 oz Oblong Square 28/415

Stock Code:
000800880290000

Manufacturing Process:
Extrusion Blow Molding

Overflow Capacity:
242 - 260 ml (8.2 - 8.8 oz)

Gram Weight:
22 ± 2

Neck Finish:
28/415

Base Width (A):
2.030 ± 0.050

Overall Height (B):
5.268 ± 0.050

Max Print Area (Height):
3.250"

Max Print Area (Width):
1.250"

Case Pack: 432

Case Weight (lb): 23.8 ± 1.9

Cases Per Pallet: 16

Box Dimensions:
24 7/16 x 18 1/2 x 23

Stock Material:



CLASSIC CONTAINERS INC
1700 S. Hellman Ave.
Ontario, CA 91761
Phone: 909-930-3610
e-mail: info@classiccontainers.com
www.classiccontainers.com

FRONT VIEW

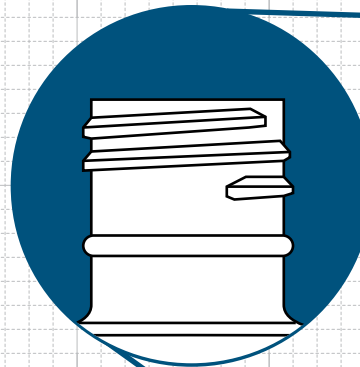
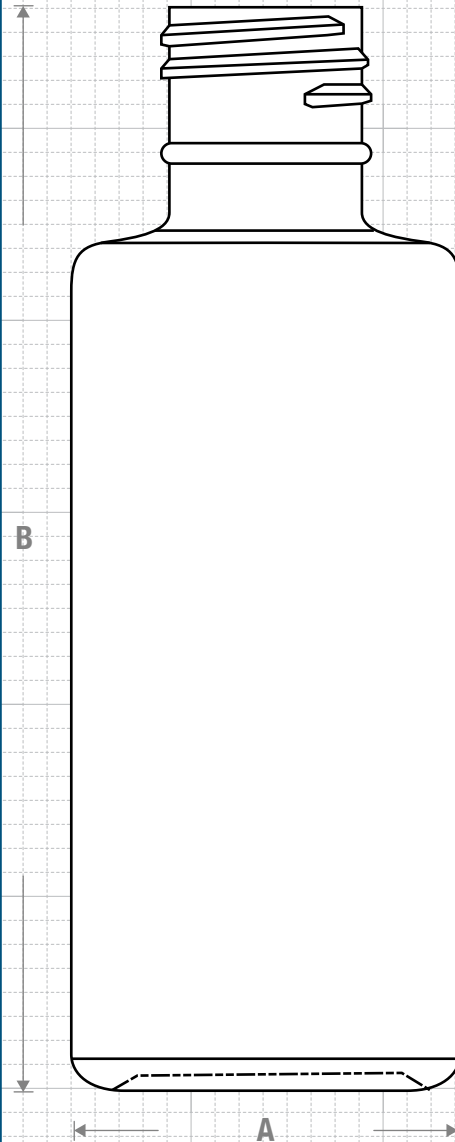

NECK & THREAD DETAIL

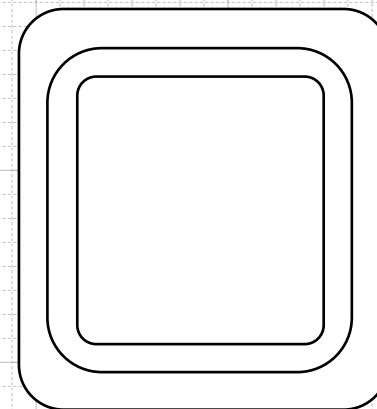
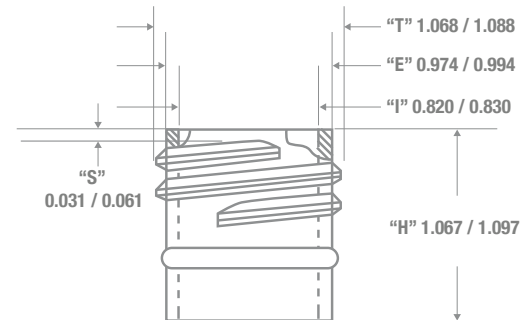

BOTTOM VIEW



PRINTING SPECIFICATIONS: 8 oz Oblong Square 28/415



1700 S Hellman Ave, Ontario, California 91761
Phone: (909) 930-3610 | Fax: (909) 930-3640
e-mail: info@classiccontainers.com
www.classiccontainers.com

A - Total Height.
B - Max. Decorating Area.
C - Total bottle circumference.
☐ - Unprintable area.