



Drawing:
8 oz Imperial Round 24/415
M2

Stock Code:
0008000502517M2

Manufacturing Process:
Stretch Blow Molding

Overflow Capacity:
254 - 271 ml (8.6 - 9.2 oz)

Gram Weight:
25 ± 1

Neck Finish:
24/415

Base Width (A):
1.885 ± 0.050

Overall Height (B):
7.074 ± 0.050

Max Print Area (Height):
4.968"

Max Print Area (Width):
5.750"

Case Pack: 396

Case Weight (lb): 24.7 ± 0.9

Cases Per Pallet: 16

Box Dimensions:
24 7/16 x 18 1/2 x 23

Stock Material:



CLASSIC CONTAINERS INC
1700 S. Hellman Ave.
Ontario, CA 91761
Phone: 909-930-3610
e-mail: info@classiccontainers.com
www.classiccontainers.com



FRONT VIEW

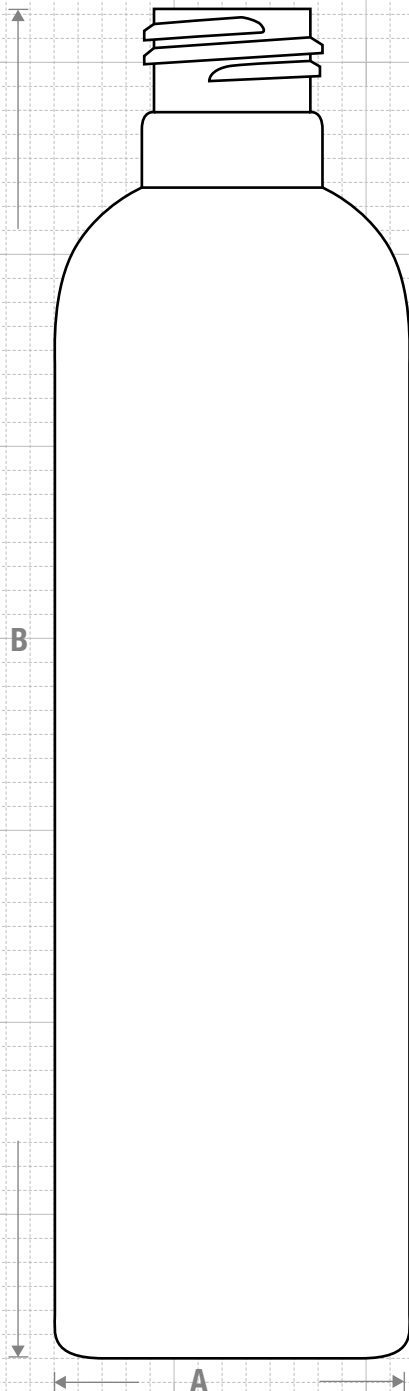

NECK & THREAD DETAIL

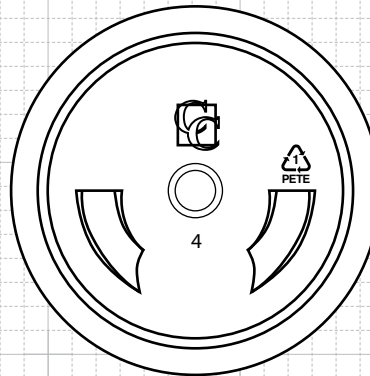
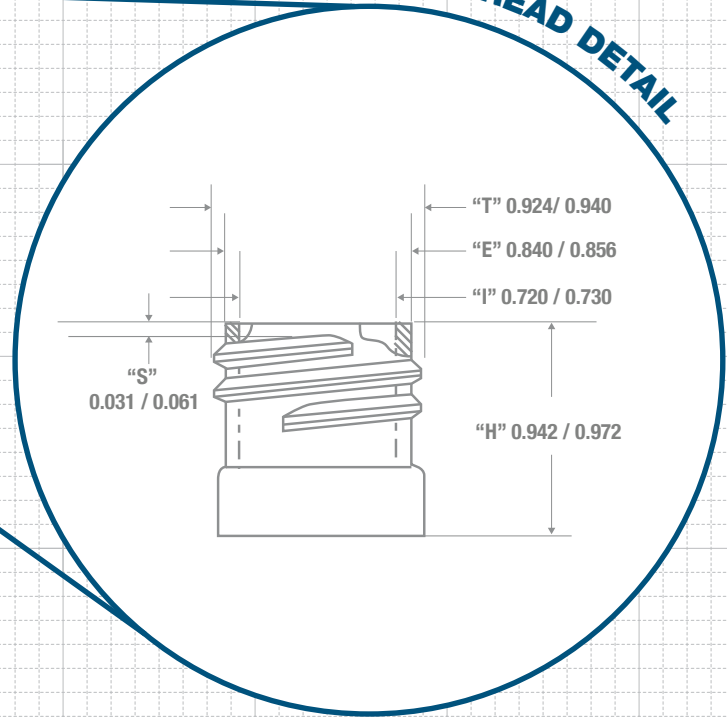
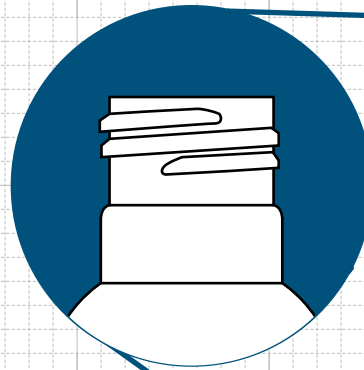

BOTTOM VIEW

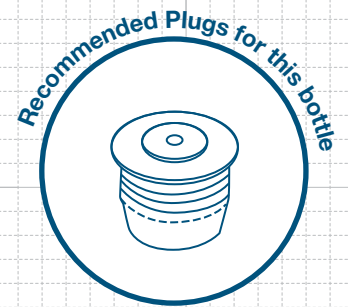

FRICITION FIT

PRINTING SPECIFICATIONS: 8 oz Imperial Round 24/415 M2

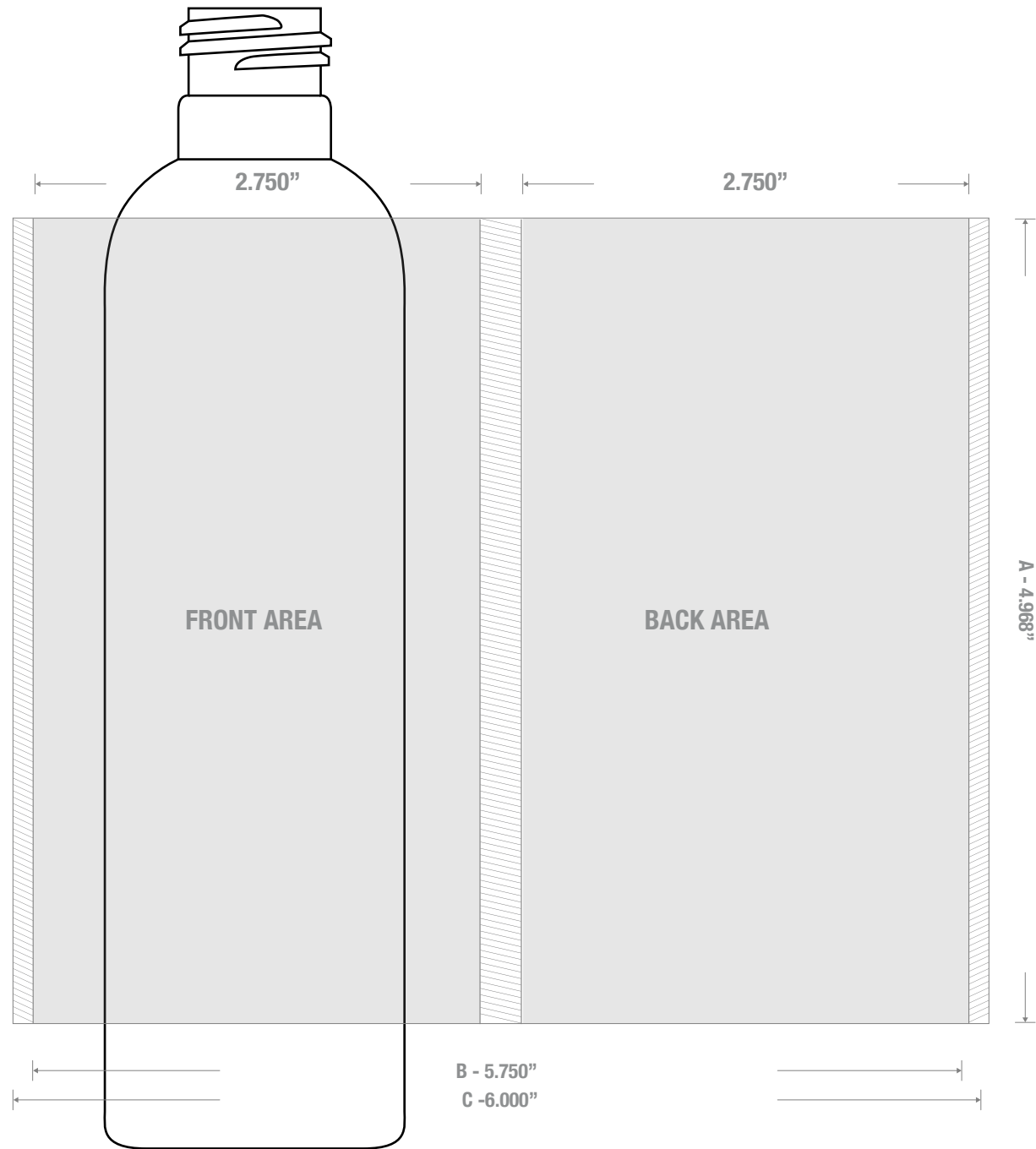

1700 S Hellman Ave, Ontario, California 91761
Phone: (909) 930-3610 | Fax: (909) 930-3640
e-mail: info@classiccontainers.com
www.classiccontainers.com

A - Total Height.
B - Max. Decorating Area.
C - Total bottle circumference.
▨ - Unprintable area.

LABELING SPECIFICATIONS: 8 oz Imperial Round 24/415 M2

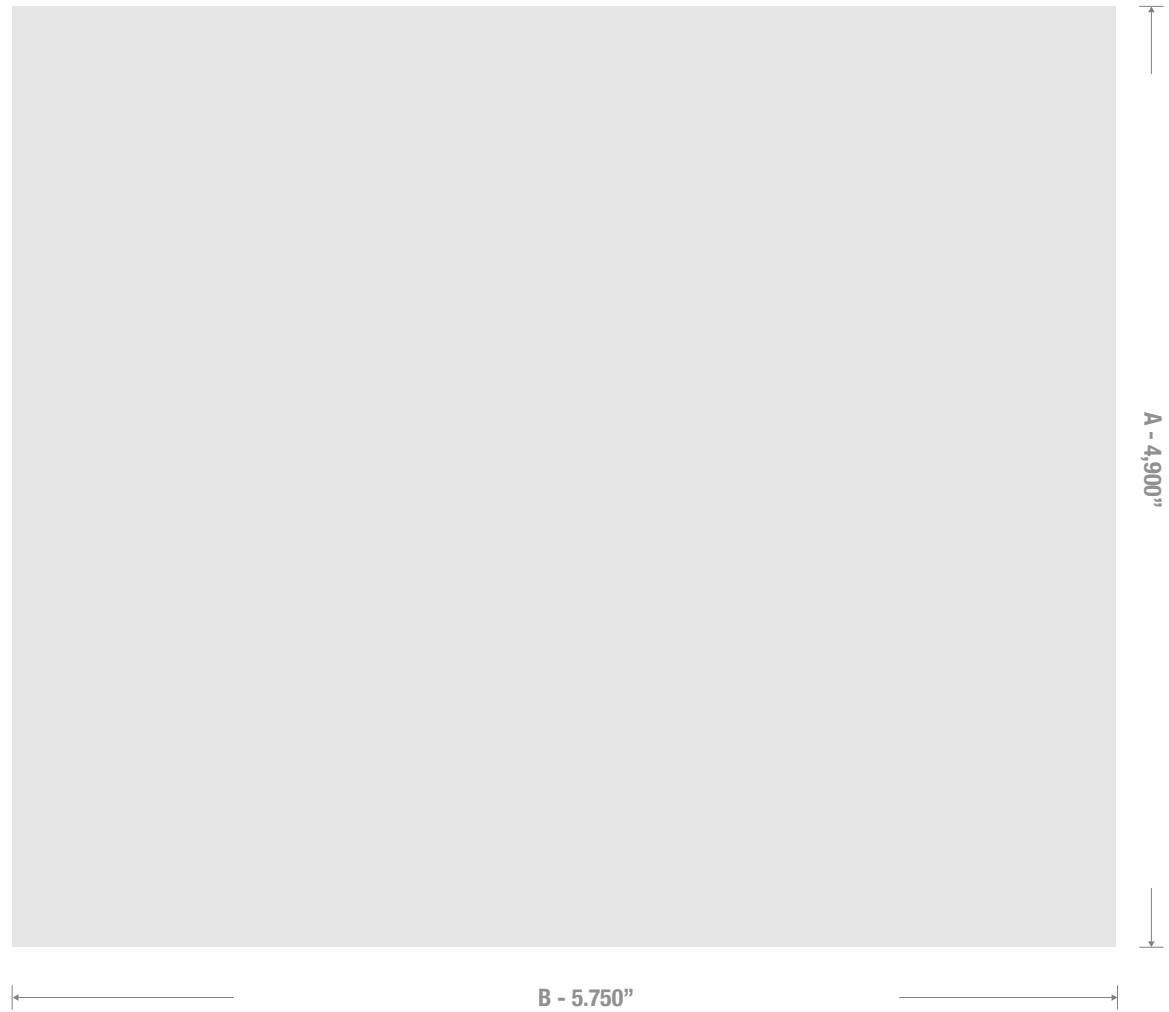

1700 S Hellman Ave, Ontario, California 91761
Phone: (909) 930-3610 | Fax: (909) 930-3640
e-mail: info@classiccontainers.com
www.classiccontainers.com

A - Total Height.
B - Max. Decorating Area.