

FRONT VIEW

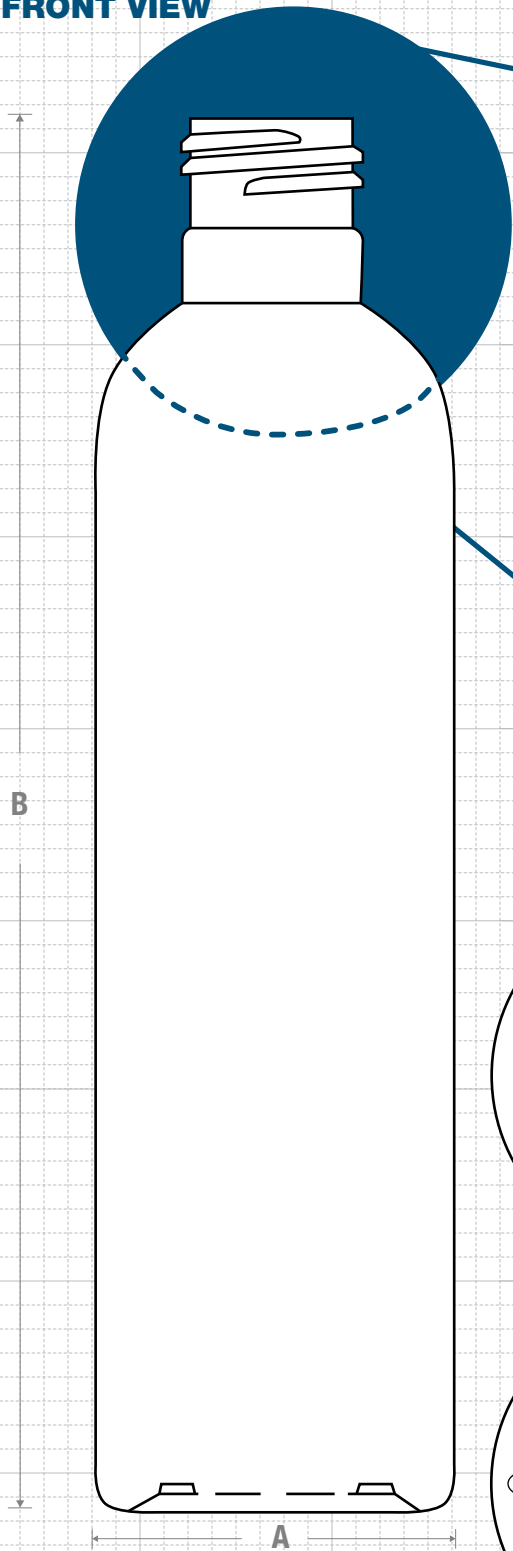

NECK & THREAD DETAIL

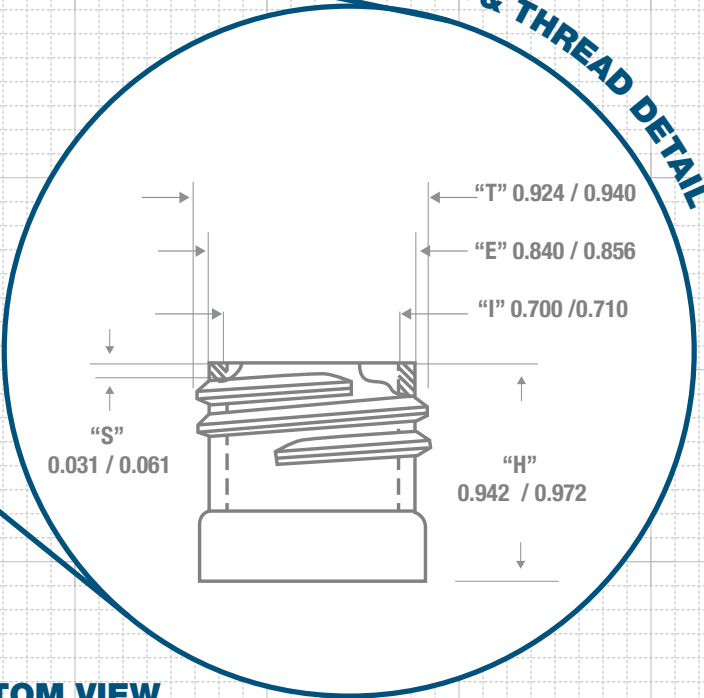

- HDPE
- LDPE
- PP
- OTHER

BOTTOM VIEW

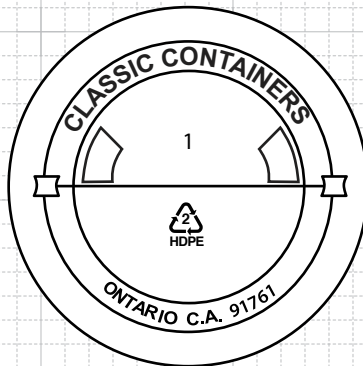

Option 1

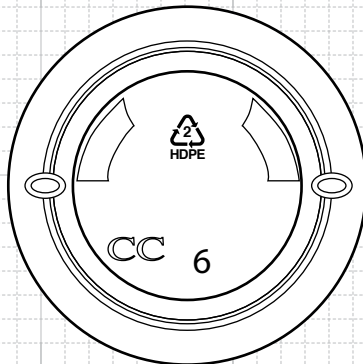

Option 2

Recommended Plugs for this bottle



FRICITION FIT



CLASSIC CONTAINERS INC
 1700 S. Hellman Ave.
 Ontario, CA 91761
 Phone: 909-930-3610
 e-mail: info@classiccontainers.com
 www.classiccontainers.com

Drawing: 8 oz Imperial Round 24/415	Gram Weight: 21. ± 2 grs	Max Print Area (Height): 5.125"	Cases Per Pallet: 16
Stock Code: 000800050250000	Neck Finish: 24/415	Max Print Area (Width): 5.625"	Box Dimensions: 24 7/16 x 18 1/2 x 23
Manufacturing Process: Extrusion Blow Molding	Base Width (A): 1.870 ± 0.050	Case Pack: 445	Stock Material: HDPE
Overflow Capacity: 251- 268 ml (8.5 - 9.1 oz)	Overall Height (B): 7.260 ± 0.050	Case Weight (lb): 23.5 ± 1.96	Rev #2 - 04/2015 Drawing not exactly to size.

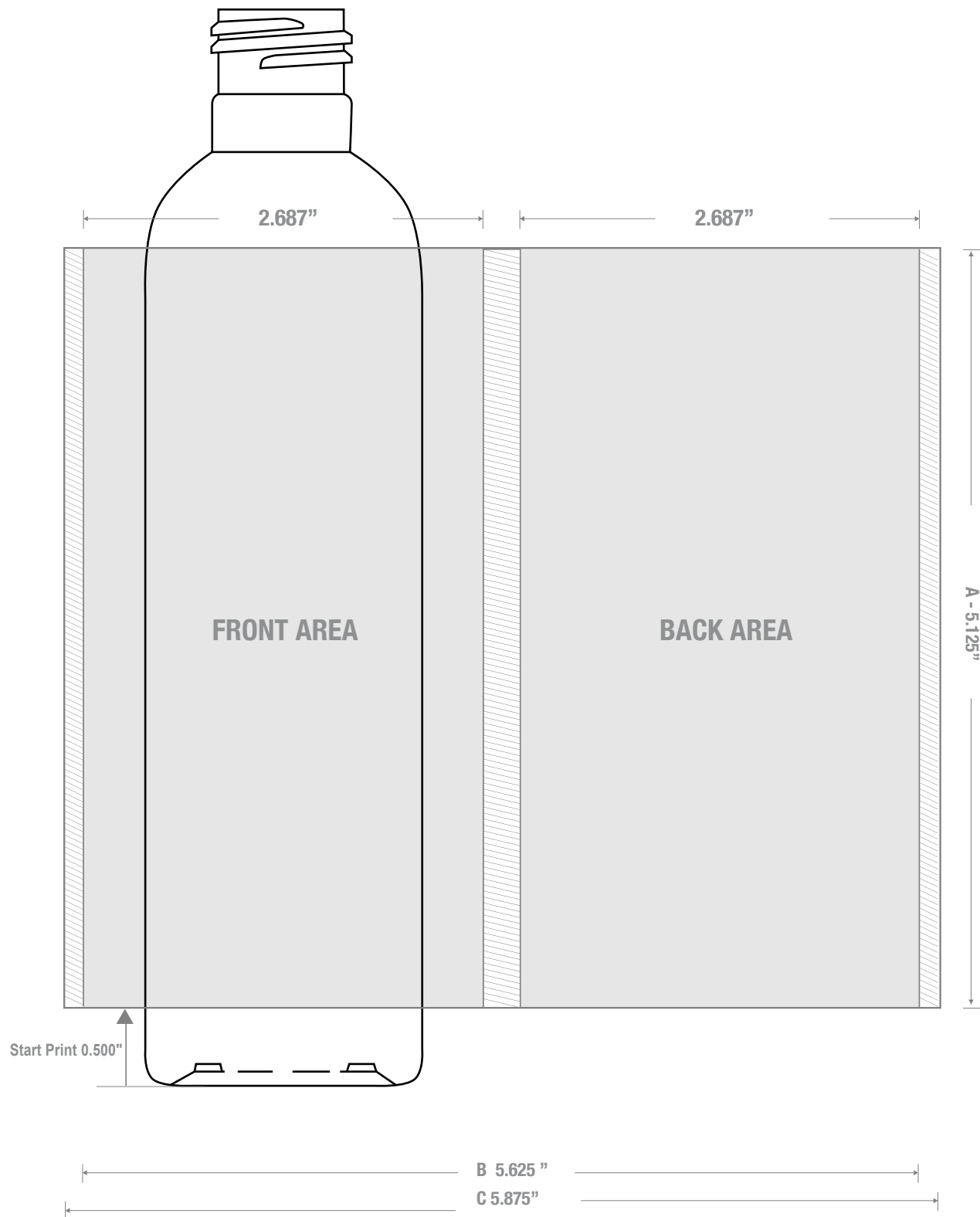

wrap label area



1700 S Hellman Ave, Ontario, California 91761
Phone: (909) 930-3610 | Fax: (909) 930-3640
e-mail: info@classiccontainers.com
www.classiccontainers.com

A - Total Height.
B - Max. Decorating Area.

Front & Back Label

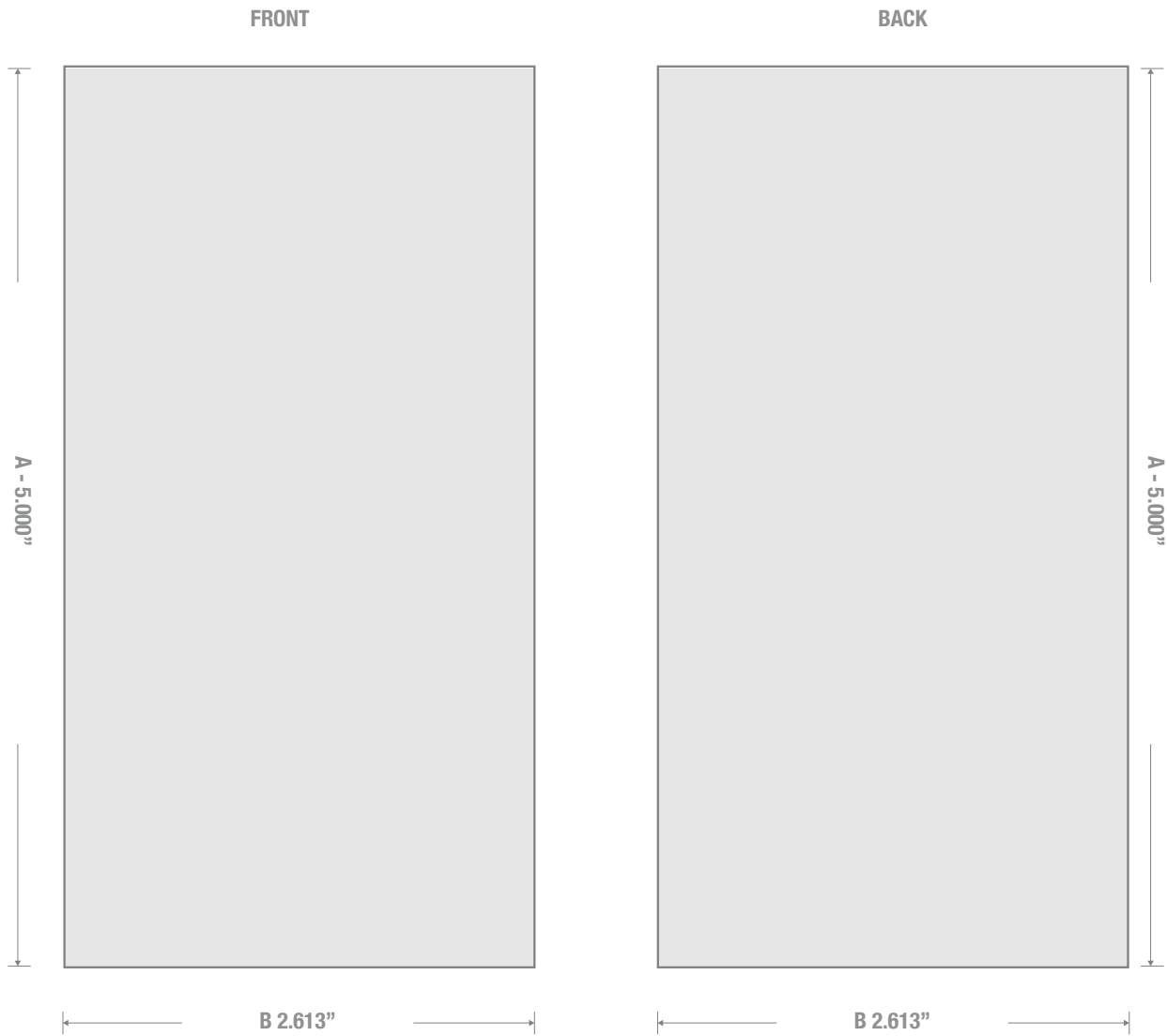

1700 S Hellman Ave, Ontario, California 91761
Phone: (909) 930-3610 | Fax: (909) 930-3640
e-mail: info@classiccontainers.com
www.classiccontainers.com

A - Total Height.
B - Max. Decorating Area.