

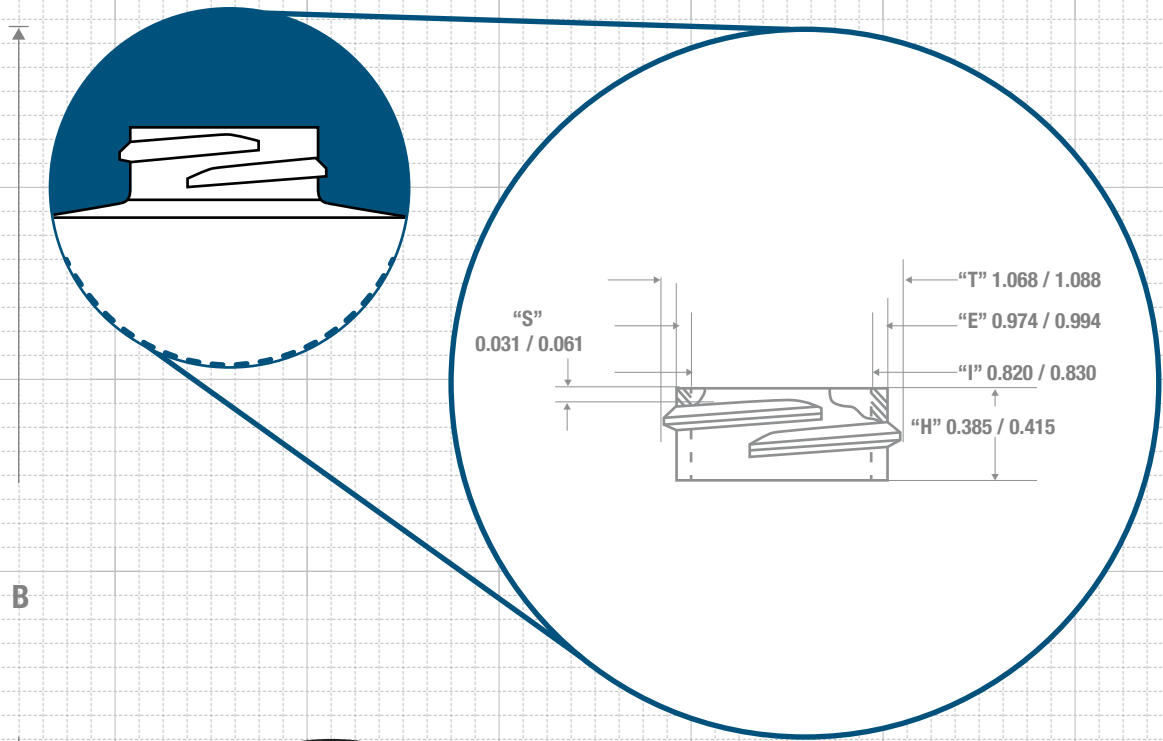

### FRONT VIEW

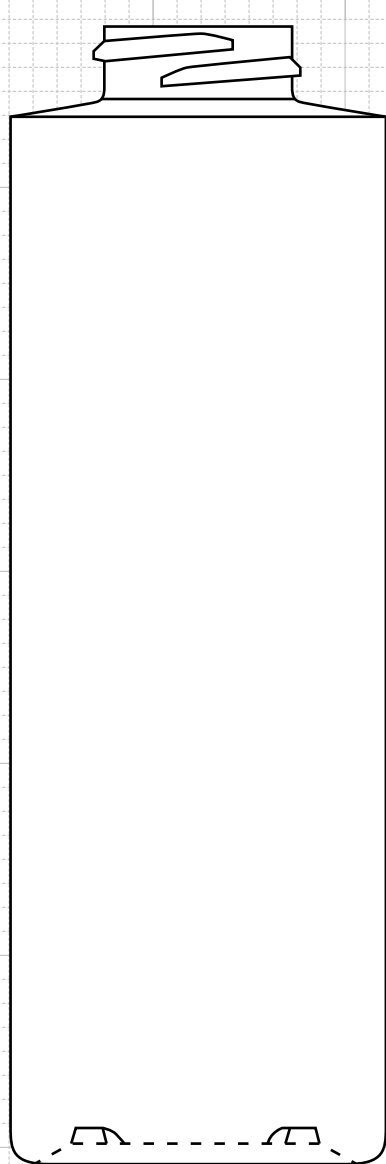

B

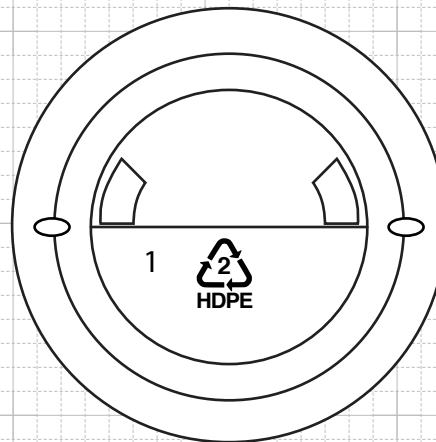

### BOTTOM VIEW

Drawing:  
8 oz Cylinder Round 28/400

Stock Code:  
000800010300000

Manufacturing Process:  
Extrusion Blow Molding

Overflow Capacity:  
245 - 263 ml (8.3 - 8.9 oz)

Gram Weight:  
22 ± 2

Neck Finish:  
28/400

Base Width (A):  
1.955 ± 0.050

Overall Height (B):  
5.925 ± 0.050

Max Print Area (Height):  
4.825"

Max Print Area (Width):  
5.938"

Case Pack: 450

Case Weight (lb): 24.7 ± 2.0

Cases Per Pallet: 16

Box Dimensions:  
24 7/16 x 18 1/2 x 23

Stock Material:



**CLASSIC CONTAINERS INC**  
1700 S. Hellman Ave.  
Ontario, CA 91761  
Phone: 909-930-3610  
e-mail: info@classiccontainers.com  
www.classiccontainers.com

# PRINTING SPECIFICATIONS: 8oz CYLINDER ROUND 28/400

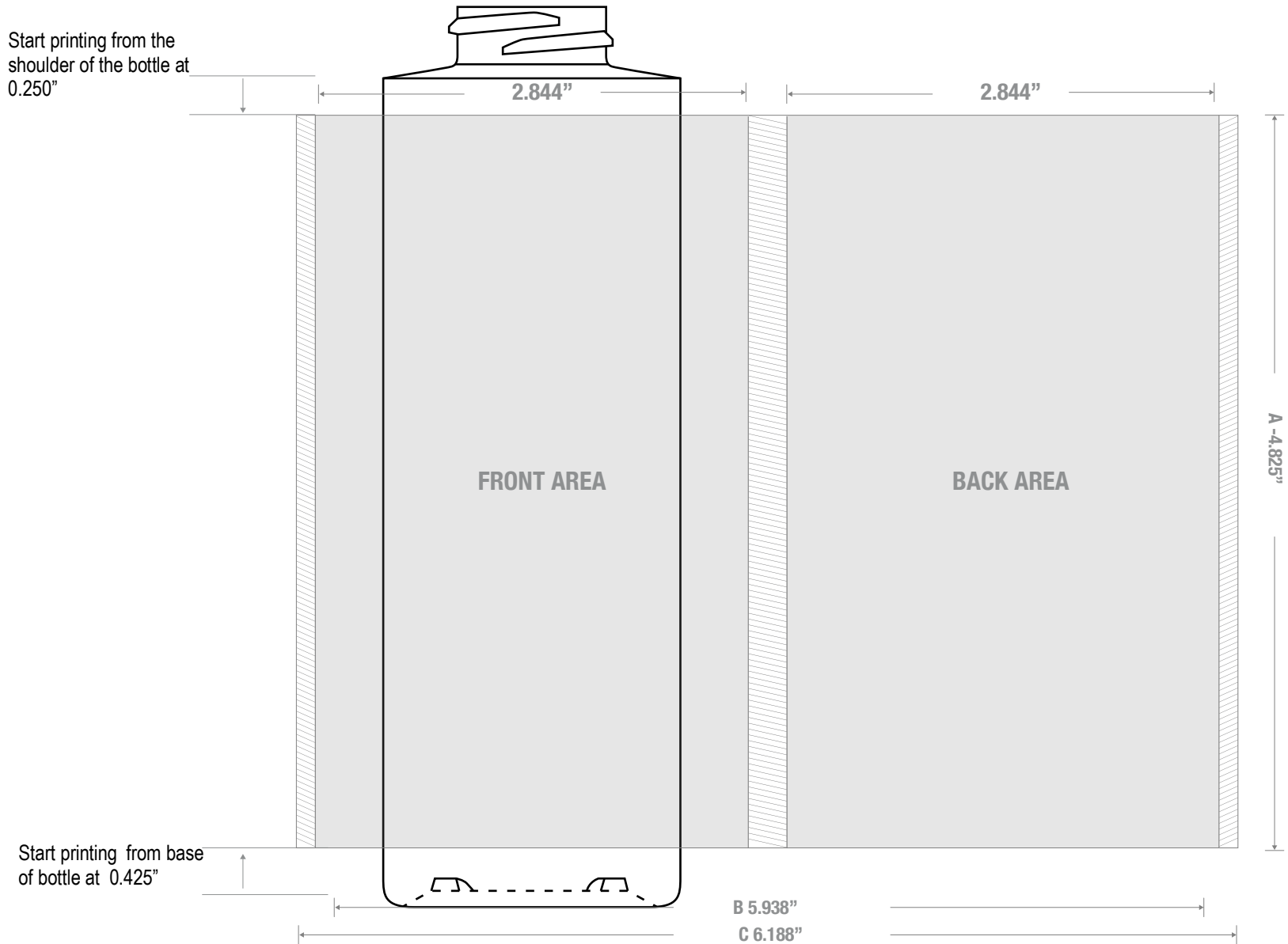

1700 S Hellman Ave, Ontario, California 91761  
 Phone: (909) 930-3610 | Fax: (909) 930-3640  
 e-mail: [info@classiccontainers.com](mailto:info@classiccontainers.com)  
[www.classiccontainers.com](http://www.classiccontainers.com)

**A - Total Height.**  
**B - Max. Decorating Area.**  
**C - Total bottle circumference.**  
 [Hatched Box] - Unprintable area.

# LABELING SPECIFICATIONS: 8oz CYLINDER ROUND 28/400



1700 S Hellman Ave, Ontario, California 91761  
Phone: (909) 930-3610 | Fax: (909) 930-3640  
e-mail: [info@classiccontainers.com](mailto:info@classiccontainers.com)  
[www.classiccontainers.com](http://www.classiccontainers.com)

**A - Total Height.**  
**B - Total bottle circumference.**