

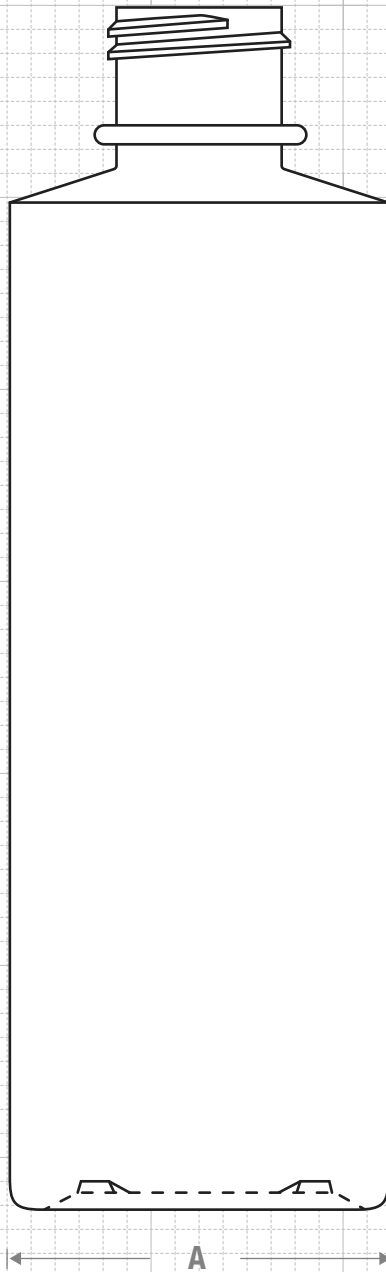

FRONT VIEW



B

A

NECK & THREAD DETAIL

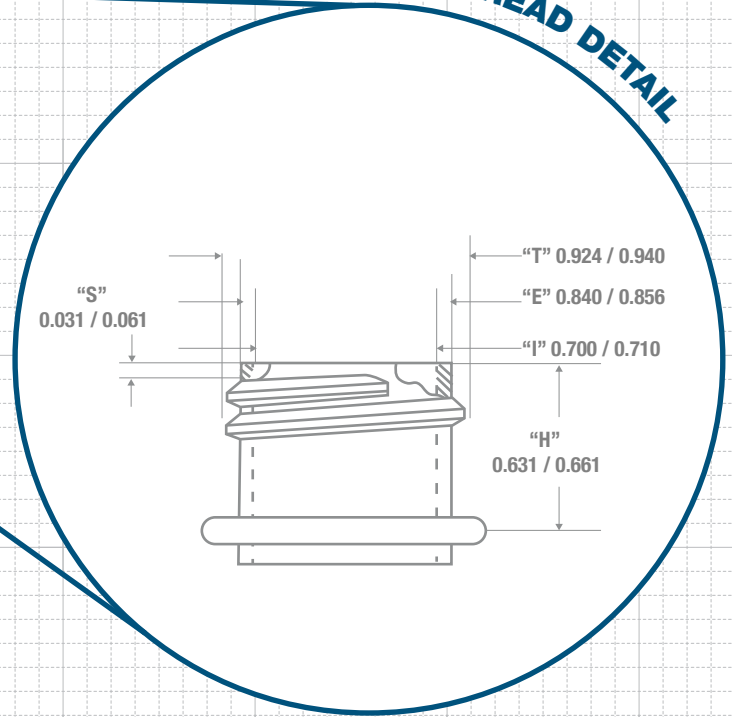
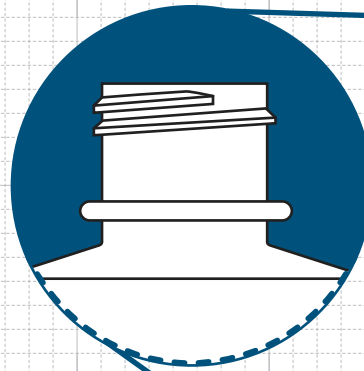

Drawing:
8 oz Cylinder Round 24/410
w/ Ring

Stock Code:
0008000124R0000

Manufacturing Process:
Extrusion Blow Molding

Overflow Capacity:
245 - 263 ml (8.3 - 8.9 oz)

Gram Weight:
22 ± 2

Neck Finish:
24/410 W/R

Base Width (A):
1.955 ± 0.050

Overall Height (B):
6.500 ± 0.050

Max Print Area (Height):
4.825"

Max Print Area (Width):
5.938"

Case Pack: 390

Case Weight (lb): 21.8 ± 1.7

Cases Per Pallet: 16

Box Dimensions:
24 7/16 x 18 1/2 x 23

Stock Material:



TOP VIEW

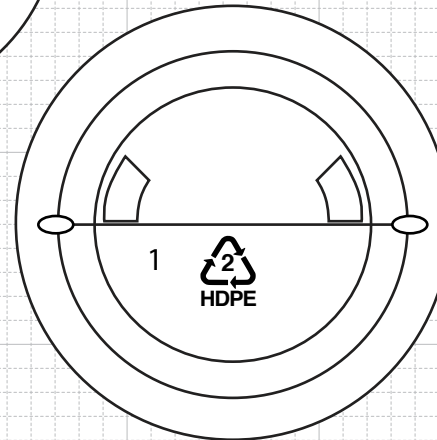
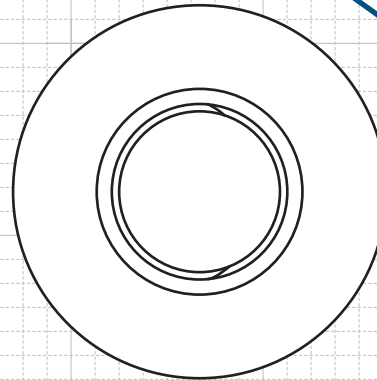

BOTTOM VIEW

Recommended Plugs for this bottle



FRICION FIT

CLASSIC CONTAINERS INC
1700 S. Hellman Ave.
Ontario, CA 91761
Phone: 909-930-3610
e-mail: info@classiccontainers.com
www.classiccontainers.com

PRINTING SPECIFICATIONS: 8oz CYLINDER ROUND 24/410 w/Ring

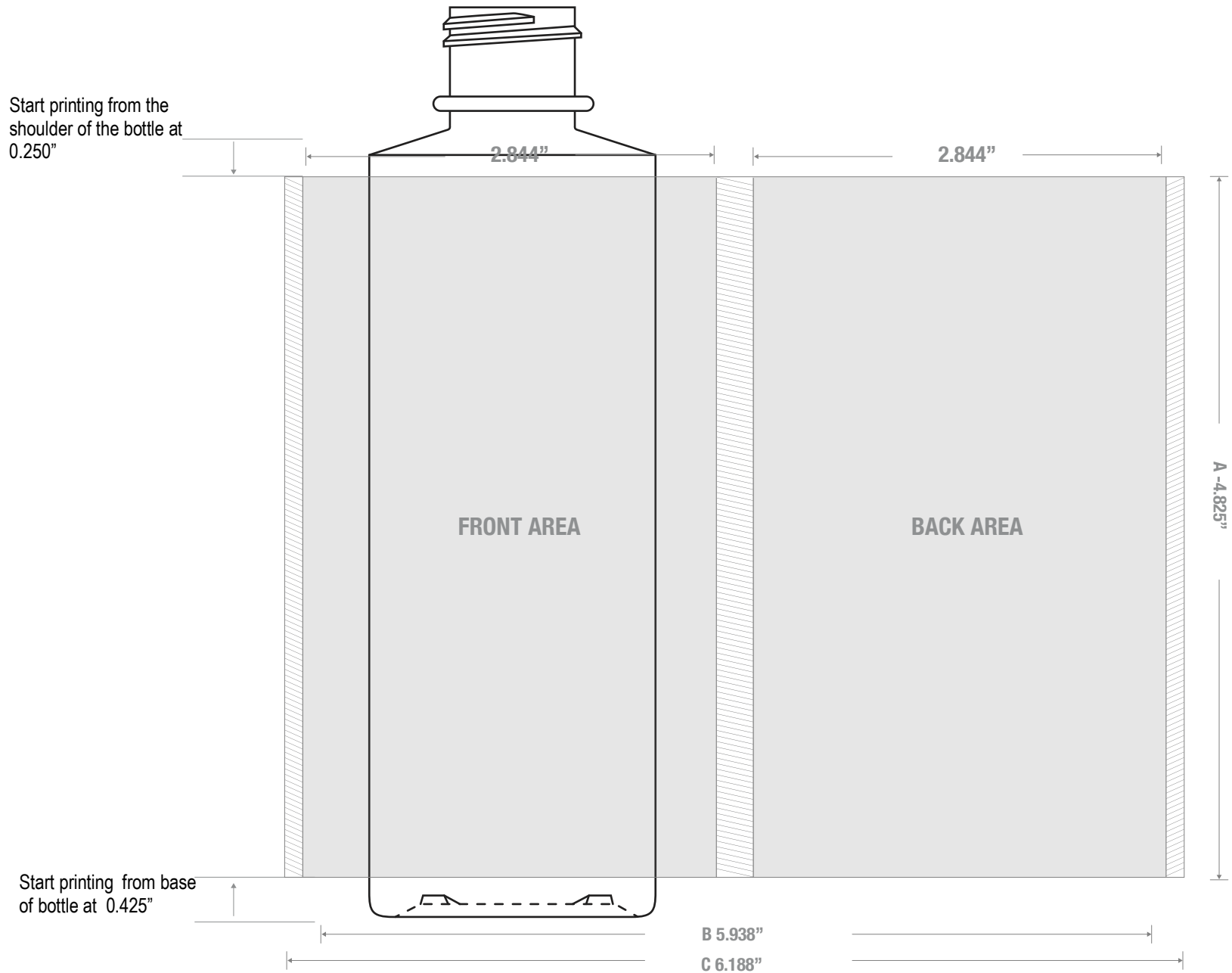

1700 S Hellman Ave, Ontario, California 91761
 Phone: (909) 930-3610 | Fax: (909) 930-3640
 e-mail: info@classiccontainers.com
www.classiccontainers.com

A - Total Height.
B - Max. Decorating Area.
C - Total bottle circumference.
 [Hatched Box] - Unprintable area.

LABELING SPECIFICATIONS: 8oz CYLINDER ROUND 24/410 w/Ring

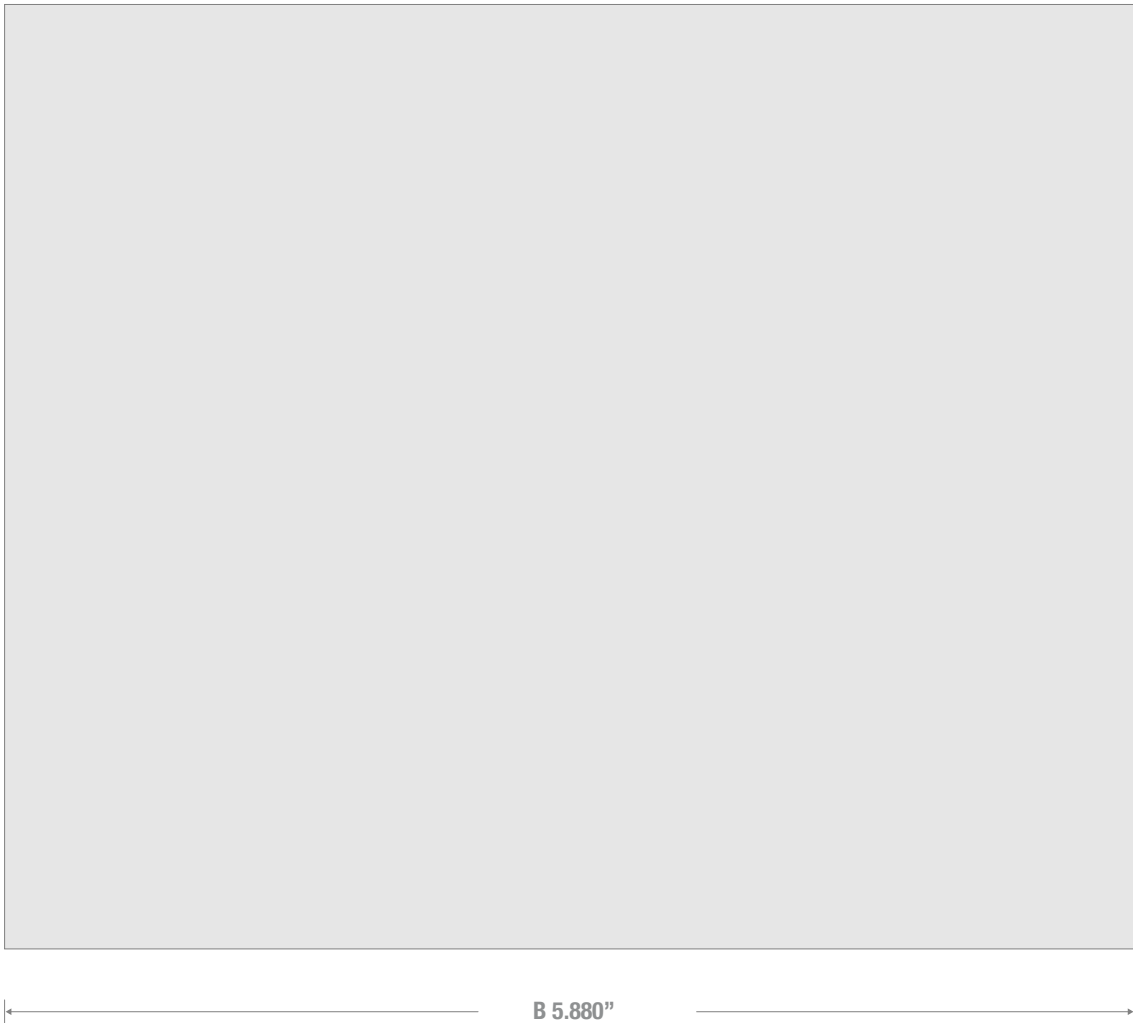

1700 S Hellman Ave, Ontario, California 91761
Phone: (909) 930-3610 | Fax: (909) 930-3640
e-mail: info@classiccontainers.com
www.classiccontainers.com

A - Total Height.
B - Total bottle circumference.

Printing over a mold part line is discouraged due to the fact that may lead to missing characters or un-printed.