

**FRONT VIEW**

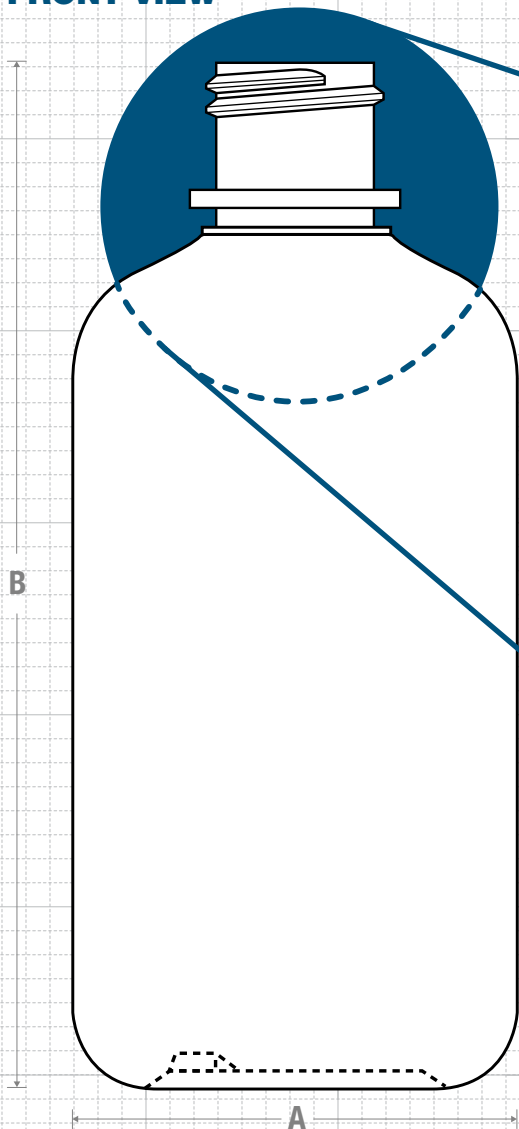

**NECK & THREAD DETAIL**

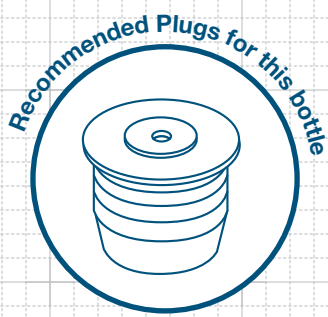
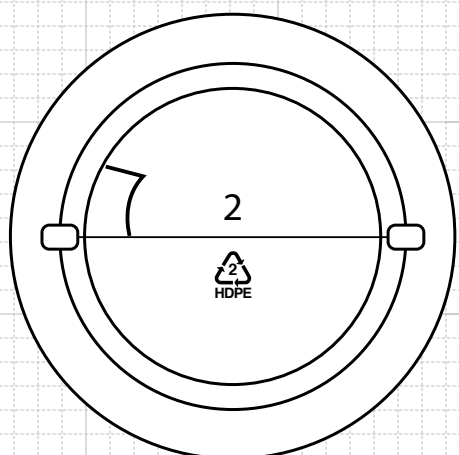
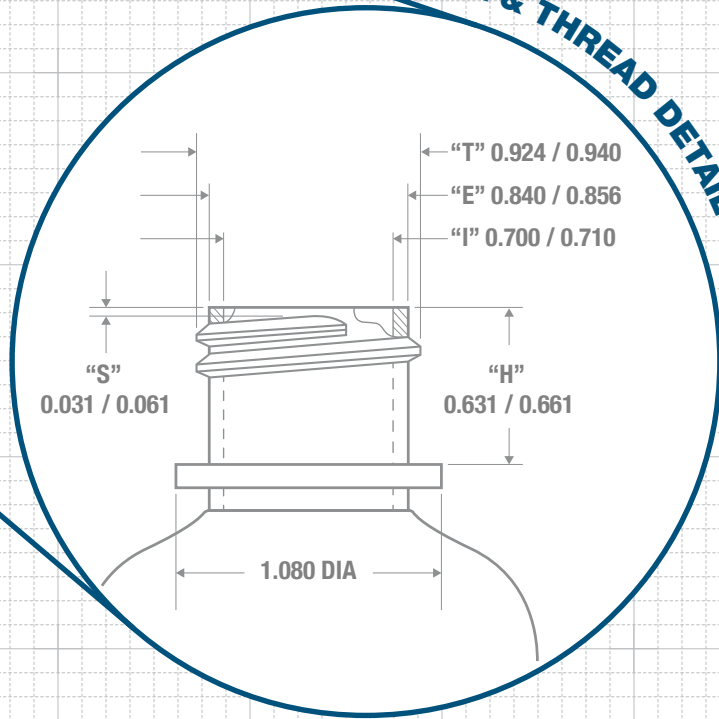

**FRICITION FIT**

**BOTTOM VIEW**



**CLASSIC CONTAINERS INC**  
 1700 S. Hellman Ave.  
 Ontario, CA 91761  
 Phone: 909-930-3610  
 e-mail: info@classiccontainers.com  
 www.classiccontainers.com

Drawing: <b>8 oz Boston Round 24/410 with Ring</b>	Gram Weight: <b>21.5 ± 2</b>	Max Print Area (Height): <b>3.063"</b>	Cases Per Pallet: <b>16</b>
Stock Code: <b>0008000624R0000</b>	Neck Finish: <b>24/410 W/Ring</b>	Max Print Area (Width): <b>7.000"</b>	Box Dimensions: <b>24 7/16 x 18 1/2 x 23</b>
Manufacturing Process: <b>Extrusion Blow Molding</b>	Base Width (A): <b>2.315 ± 0.050</b>	Case Pack: <b>394</b>	Stock Material:
Overflow Capacity: <b>260 - 280 ml (8.8 - 9.5 oz)</b>	Overall Height (B): <b>5.345 ± 0.050</b>	Case Weight (lb): <b>21.6 ± 1.7</b>	Rev #5 - 03/2020 Drawing not exactly to size.

# PRINTING SPECIFICATIONS: 8 oz BOSTON ROUND

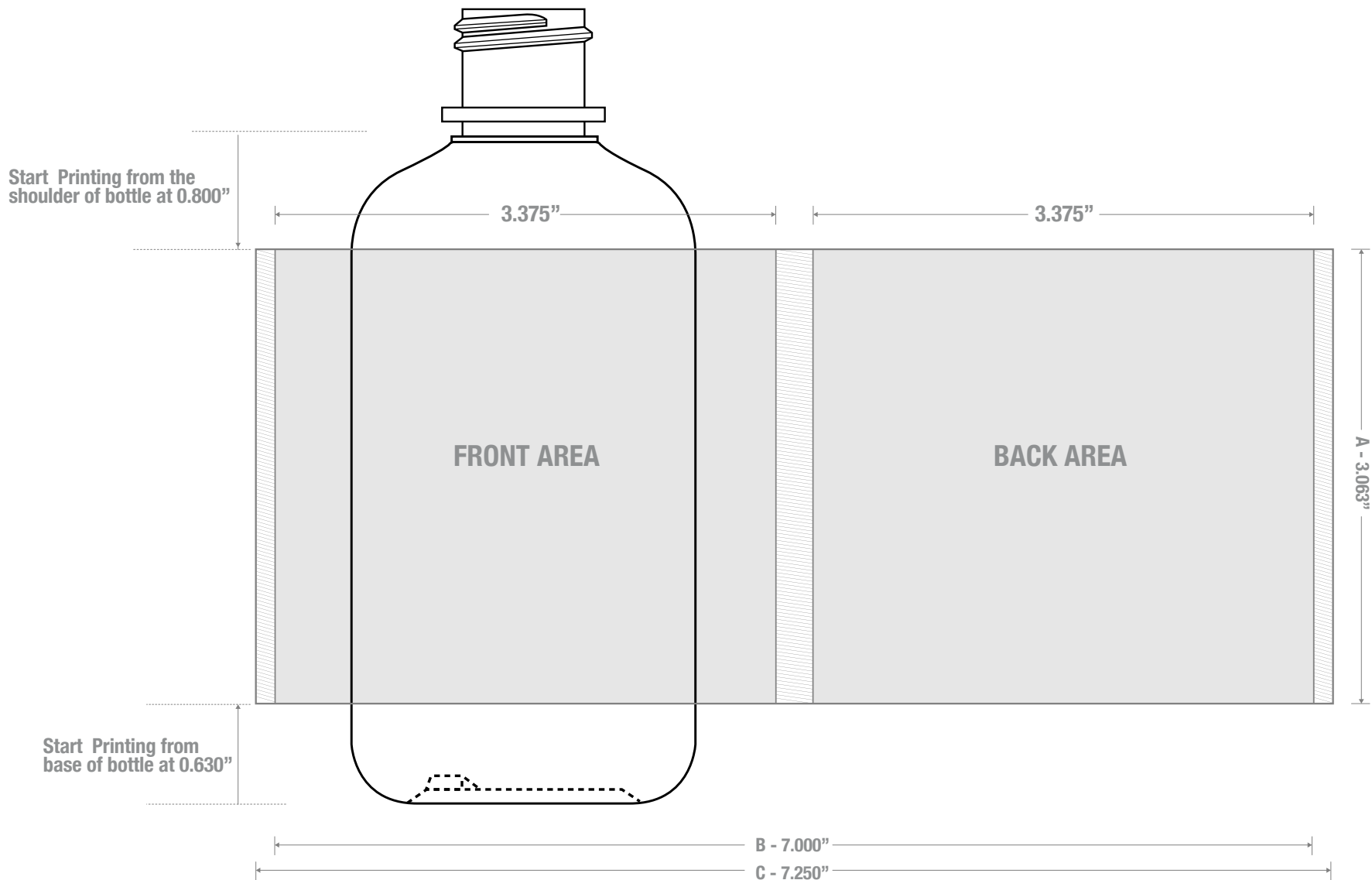

1700 S Hellman Ave, Ontario, California 91761  
Phone: (909) 930-3610 | Fax: (909) 930-3640  
e-mail: [info@classiccontainers.com](mailto:info@classiccontainers.com)  
[www.classiccontainers.com](http://www.classiccontainers.com)

A - Total Height.  
B - Max. Decorating Area.  
C - Total bottle circumference.  
☐ - Unprintable area.

# LABELING SPECIFICATIONS: 8 oz BOSTON ROUND

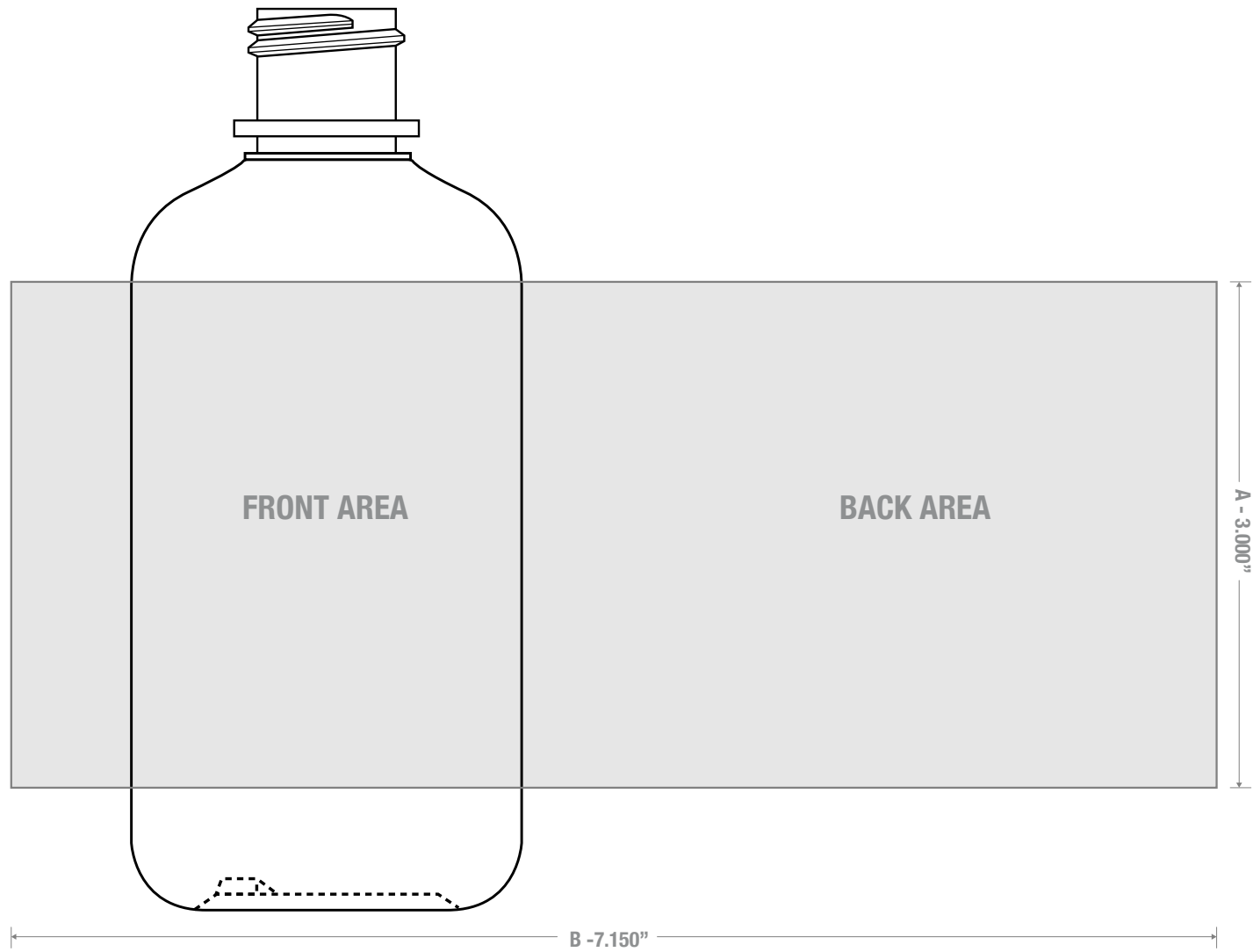

1700 S Hellman Ave, Ontario, California 91761  
Phone: (909) 930-3610 | Fax: (909) 930-3640  
e-mail: [info@classiccontainers.com](mailto:info@classiccontainers.com)  
[www.classiccontainers.com](http://www.classiccontainers.com)

**A - Total Height.**  
**B - Max. Decorating Area.**