



FRONT VIEW

Drawing:
75 ml Cylinder Round 20/410

Stock Code:
00750001020000

Manufacturing Process:
Extrusion Blow Molding

Overflow Capacity:
67.9 - 76.7 ml (2.3 - 2.6 oz)

Gram Weight:
12 ± 1

Neck Finish:
20/410

Base Width (A):
1.240 ± 0.050

Overall Height (B):
4.865 ± 0.050

Max Print Area (Height):
3.695"

Max Print Area (Width):
3.690"

Case Pack: 810

Case Weight (lb): 23.5 ± 1.8

Cases Per Pallet: 25

Box Dimensions:
23 5/8 x 15 9/16 x 17

Stock Material:



CLASSIC CONTAINERS INC
1700 S. Hellman Ave.
Ontario, CA 91761
Phone: 909-930-3610
e-mail: info@classiccontainers.com
www.classiccontainers.com

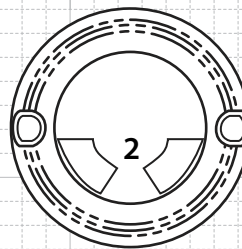
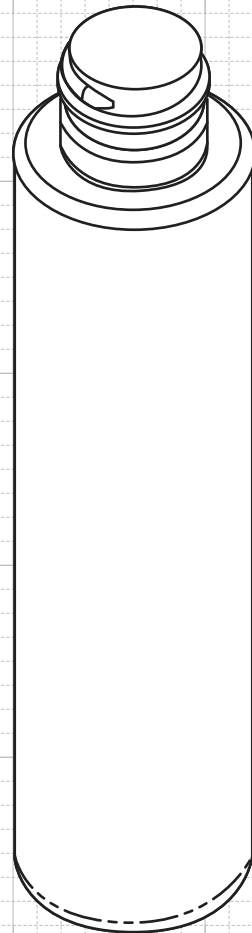
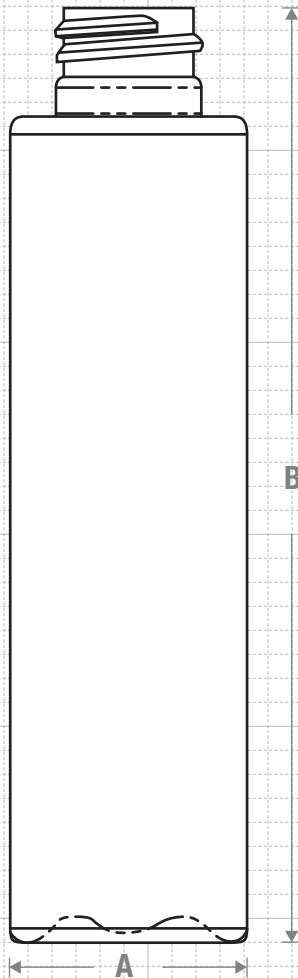

BOTTOM VIEW

NECK & THREAD DETAIL

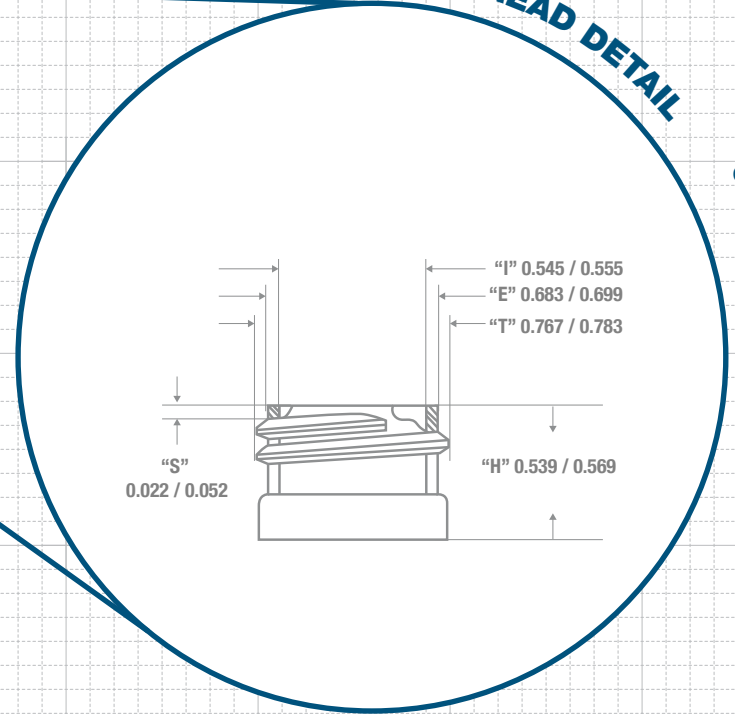

Recommended Plugs for this bottle



Recommended Plugs for this bottle



FRICION FIT



PRINTING SPECIFICATIONS: 75 ml CYLINDER ROUND 20/410

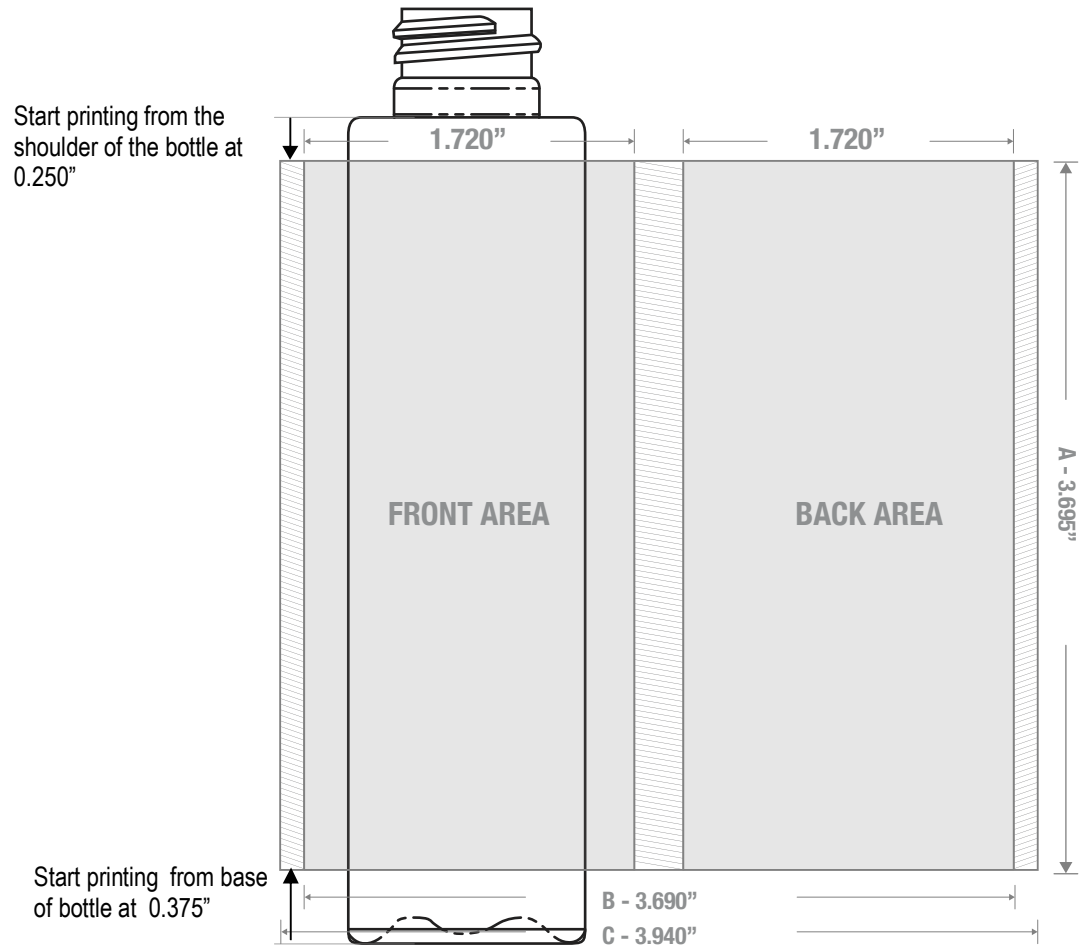

1700 S Hellman Ave, Ontario, California 91761
Phone: (909) 930-3610 | Fax: (909) 930-3640
e-mail: info@classiccontainers.com
www.classiccontainers.com

A - Total Height.
B - Max. Decorating Area.
C - Total bottle circumference.
☒ - Unprintable area.

LABELING SPECIFICATIONS: 75 ml CYLINDER ROUND 20/410

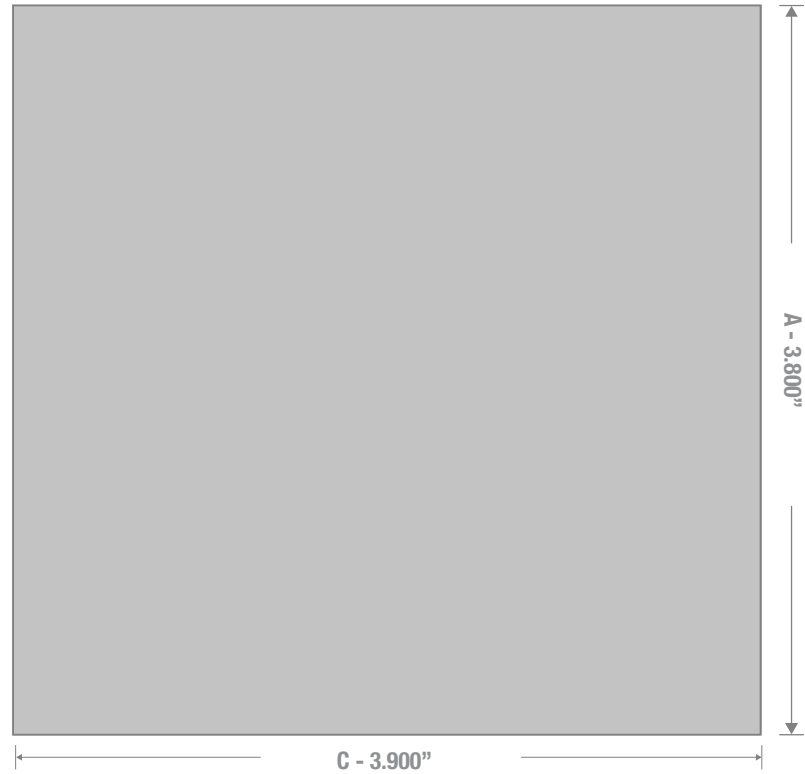

1700 S Hellman Ave, Ontario, California 91761
Phone: (909) 930-3610 | Fax: (909) 930-3640
e-mail: info@classiccontainers.com
www.classiccontainers.com

A - Total Height.
B - Total bottle circumference.