

**NECK & THREAD DETAIL**

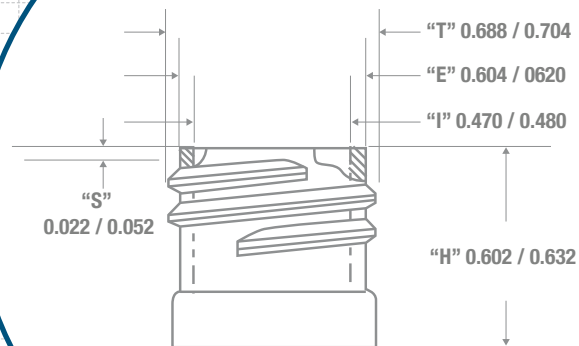

**FRONT VIEW**

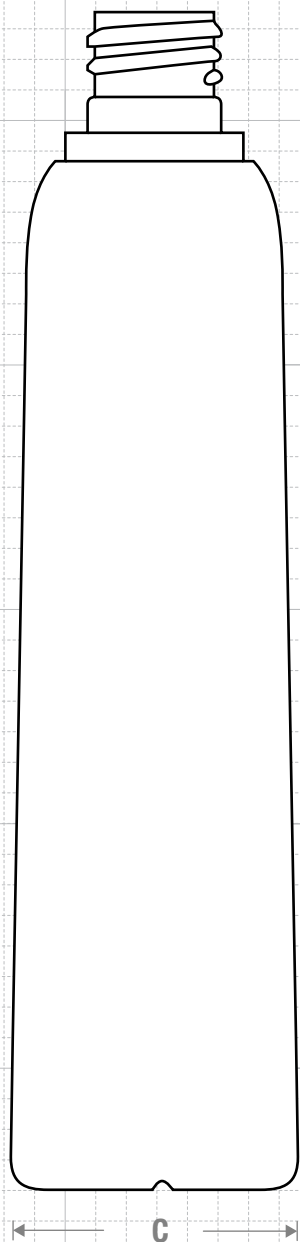
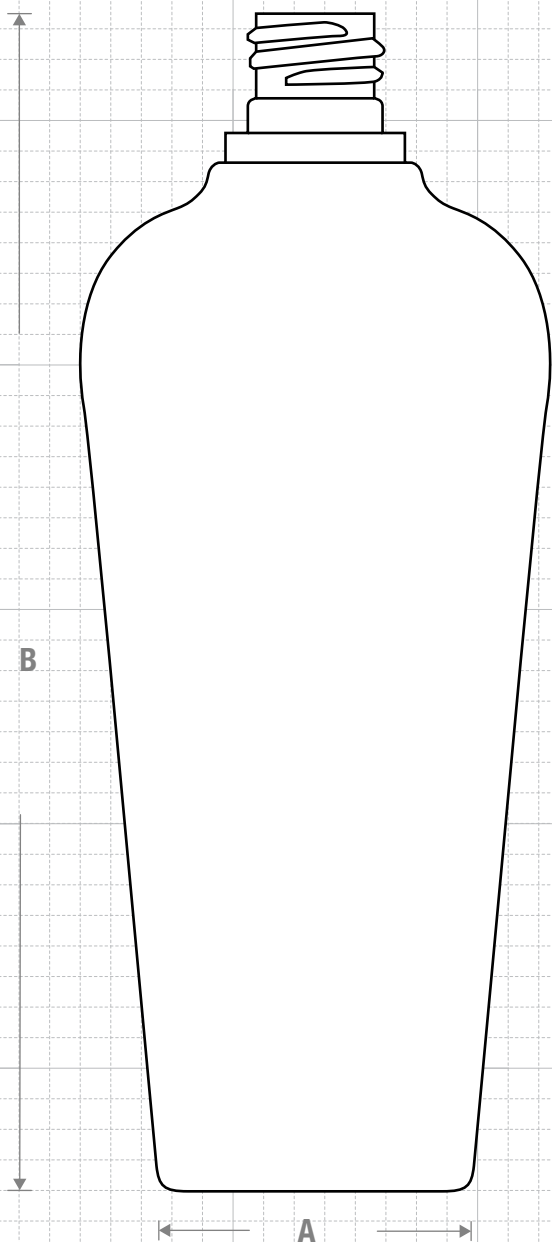

**SIDE VIEW**

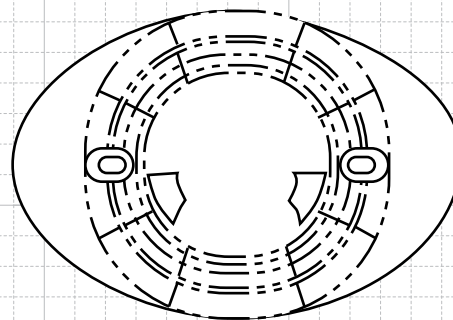

**BOTTOM VIEW**



**CLASSIC CONTAINERS INC**  
 1700 S. Hellman Ave.  
 Ontario, CA 91761  
 Phone: 909-930-3610  
 e-mail: info@classiccontainers.com  
 www.classiccontainers.com

Drawing:  
**6 oz Vail Oval 18/415**

Gram Weight:  
**20.0 ± 2**

Max Print Area (Height):  
**4.000**

Cases Per Pallet: **16**

Stock Code:  
**000600100190000**

Neck Finish:  
**18/415**

Max Print Area (Width):  
 Shoulder: **1.453"** Base: **0.875"**

Box Dimensions:  
**24 7/16 x 18 1/2 x 23**

Manufacturing Process:  
**Extrusion Blow Molding**

Base Width (A) Base Deep (C):  
**1.650± 0.050 1.535± 0.050**

Case Pack: **516**

Stock Material:



Overflow Capacity:  
**183 - 195 ml (6.2 - 6.6 oz)**

Overall Height (B):  
**6.160 ± 0.050**

Case Weight (lb): **25.7 ± 2.3**

Rev #3 07/2021

Drawing not exactly to size.

