

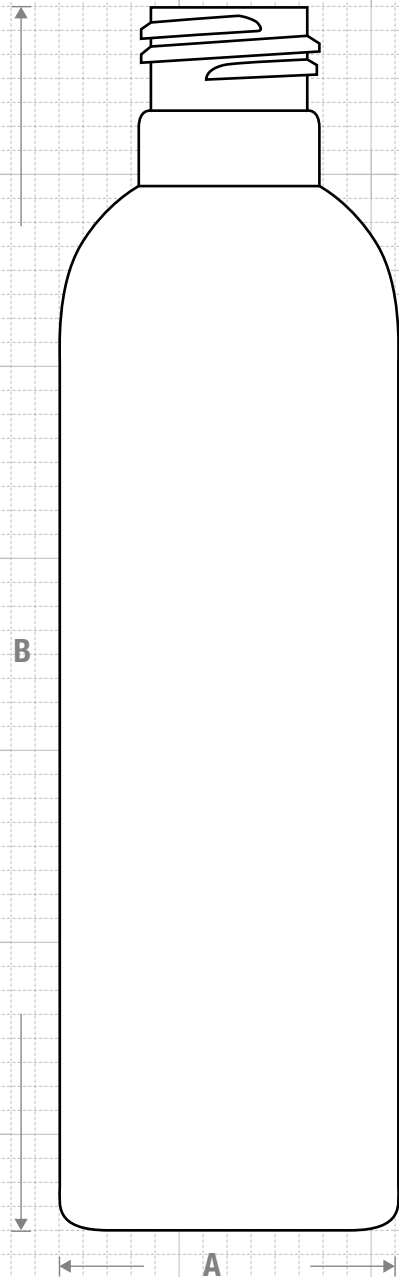

FRONT VIEW



Drawing:
6 oz Imperial Round 24/415

Stock Code:
000600050251700

Manufacturing Process:
Stretch Blow Molding

Overflow Capacity:
183 - 195 ml (6.2 - 6.6 oz)

Gram Weight:
20 ± 1

Neck Finish:
24/415

Base Width (A):
1.720 ± 0.050

Overall Height (B):
6.268 ± 0.050

Max Print Area (Height):
4.187"

Max Print Area (Width):
5.187"

Case Pack: 606

Case Weight (lb): 29.6± 1.3

Cases Per Pallet: 16

Box Dimensions:
24 7/16 x18 1/2 x23

Stock Material:



CLASSIC CONTAINERS INC
1700 S. Hellman Ave.
Ontario, CA 91761
Phone: 909-930-3610
e-mail: info@classiccontainers.com
www.classiccontainers.com

NECK & THREAD DETAIL

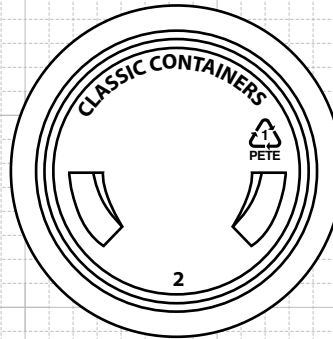
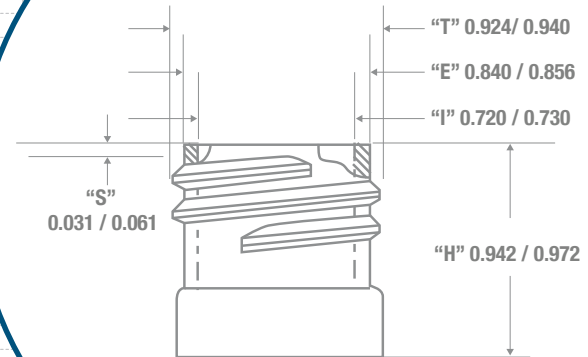
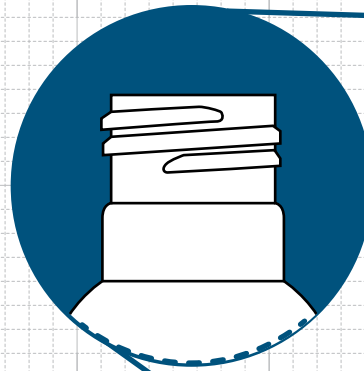

BOTTOM VIEW

Recommended Plugs for this bottle



FRICITION FIT

PRINTING SPECIFICATIONS: 6 oz Imperial Round 24/415

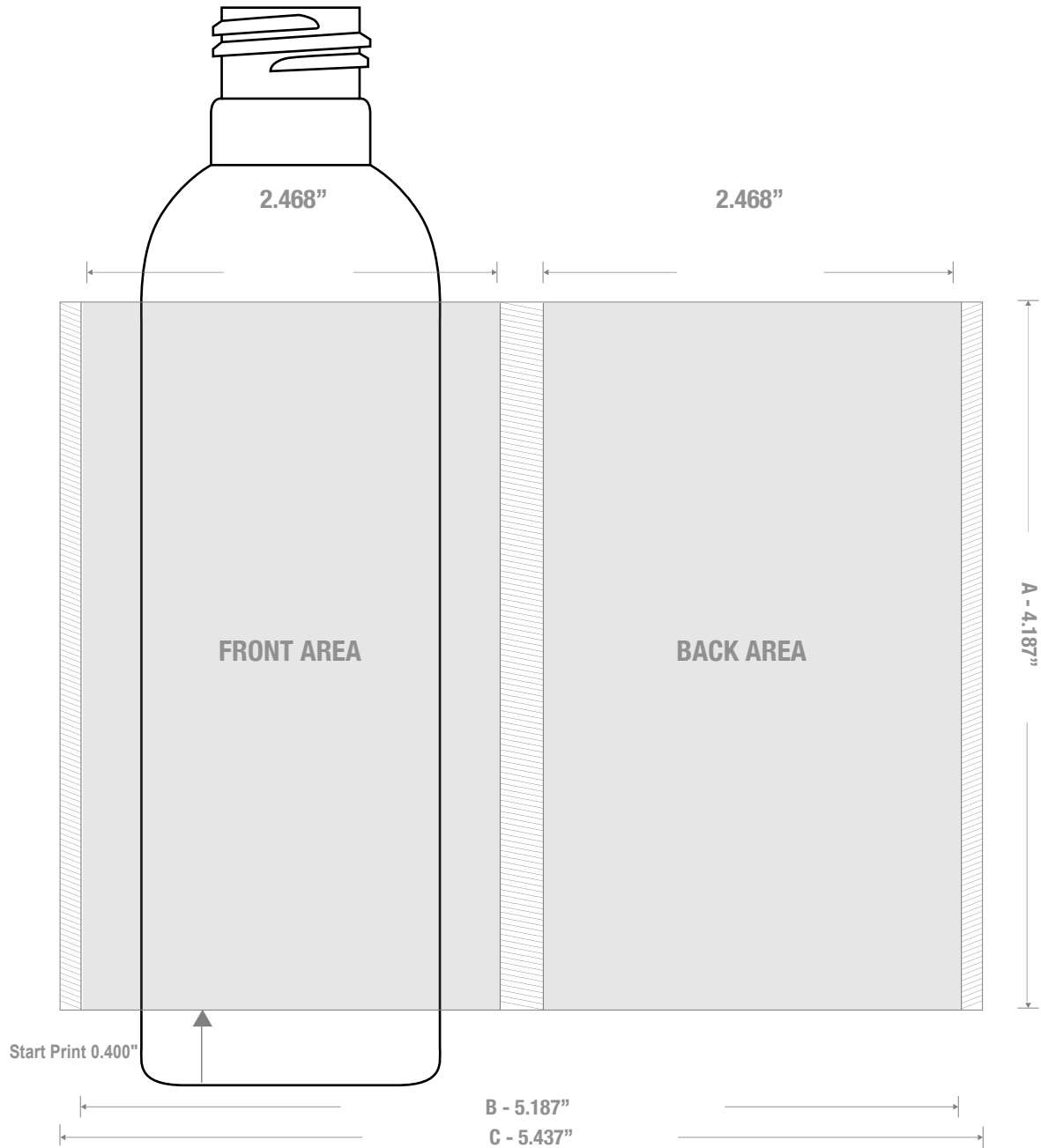

1700 S Hellman Ave, Ontario, California 91761
 Phone: (909) 930-3610 | Fax: (909) 930-3640
 e-mail: info@classiccontainers.com
www.classiccontainers.com

A - Total Height.
B - Max. Decorating Area.
C - Total bottle circumference.
 - Unprintable area.

LABELING SPECIFICATIONS: 6 oz IMPERIAL ROUND 24/415 PETE (Wrap Label)



1700 S Hellman Ave, Ontario, California 91761
Phone: (909) 930-3610 | Fax: (909) 930-3640
e-mail: info@classiccontainers.com
www.classiccontainers.com

A - Total Height.
B - Max. Decorating Area.
C - Total bottle circumference.
☐ - Unprintable area.