



Drawing:  
6 oz Evolution 24/415

Stock Code:  
000600330250000

Manufacturing Process:  
Extrusion Blow Molding

Overflow Capacity:  
209.0 - 221.0 ml (7.1 - 7.5 oz)

Gram Weight:  
18 ± 2

Neck Finish:  
24/415

Base Width (A):  
1.835 ± 0.050

Overall Height (B):  
6.591 ± 0.050

Max Print Area (Height):  
3.750"

Max Print Area (Width):  
5.500"

Case Pack: 446

Case Weight (lb): 20.6 ± 2.0

Cases Per Pallet: 16

Box Dimensions:  
24 7/16 x 18 1/2 x 23

Stock Material:



**CLASSIC CONTAINERS INC**  
1700 S. Hellman Ave.  
Ontario, CA 91761  
Phone: 909-930-3610  
e-mail: info@classiccontainers.com  
www.classiccontainers.com

### FRONT VIEW

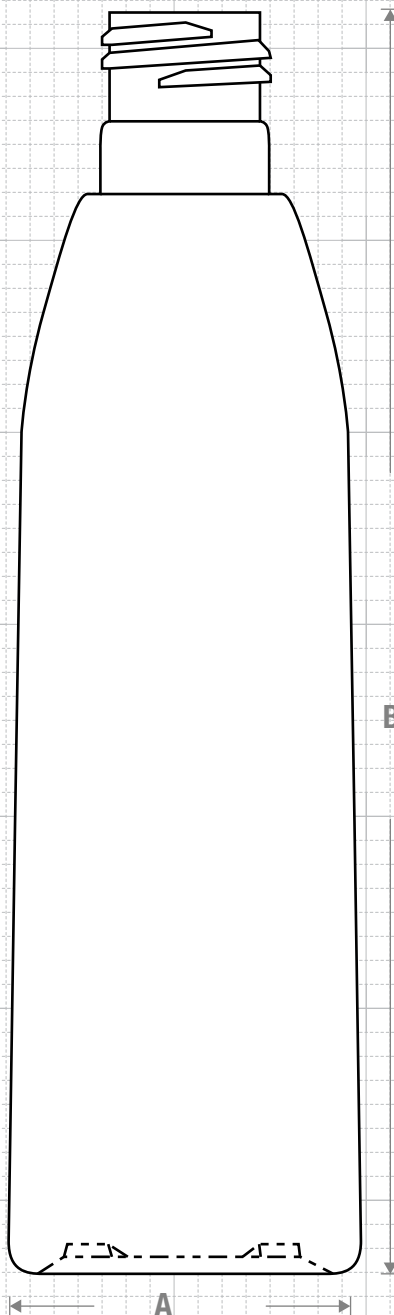

### NECK & THREAD DETAIL

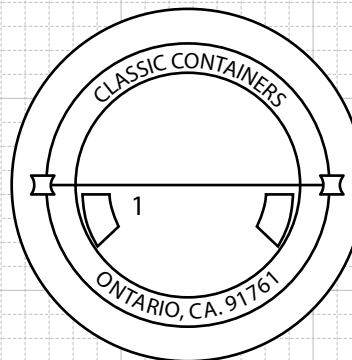
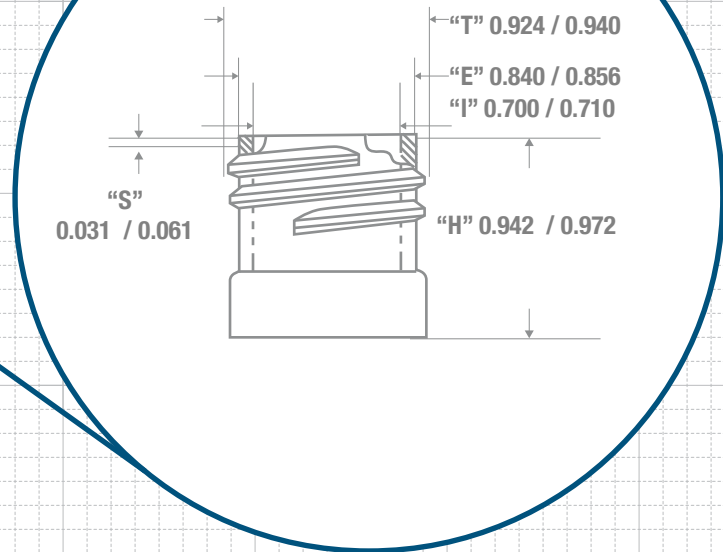

### BOTTOM VIEW

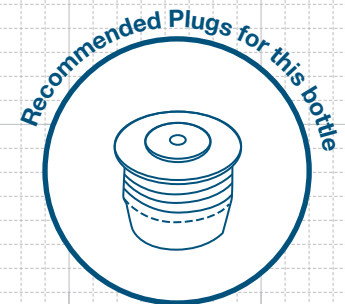

### FRICITION FIT



PRINTING SPECIFICATIONS: 6 oz EVOLUTION 24/410

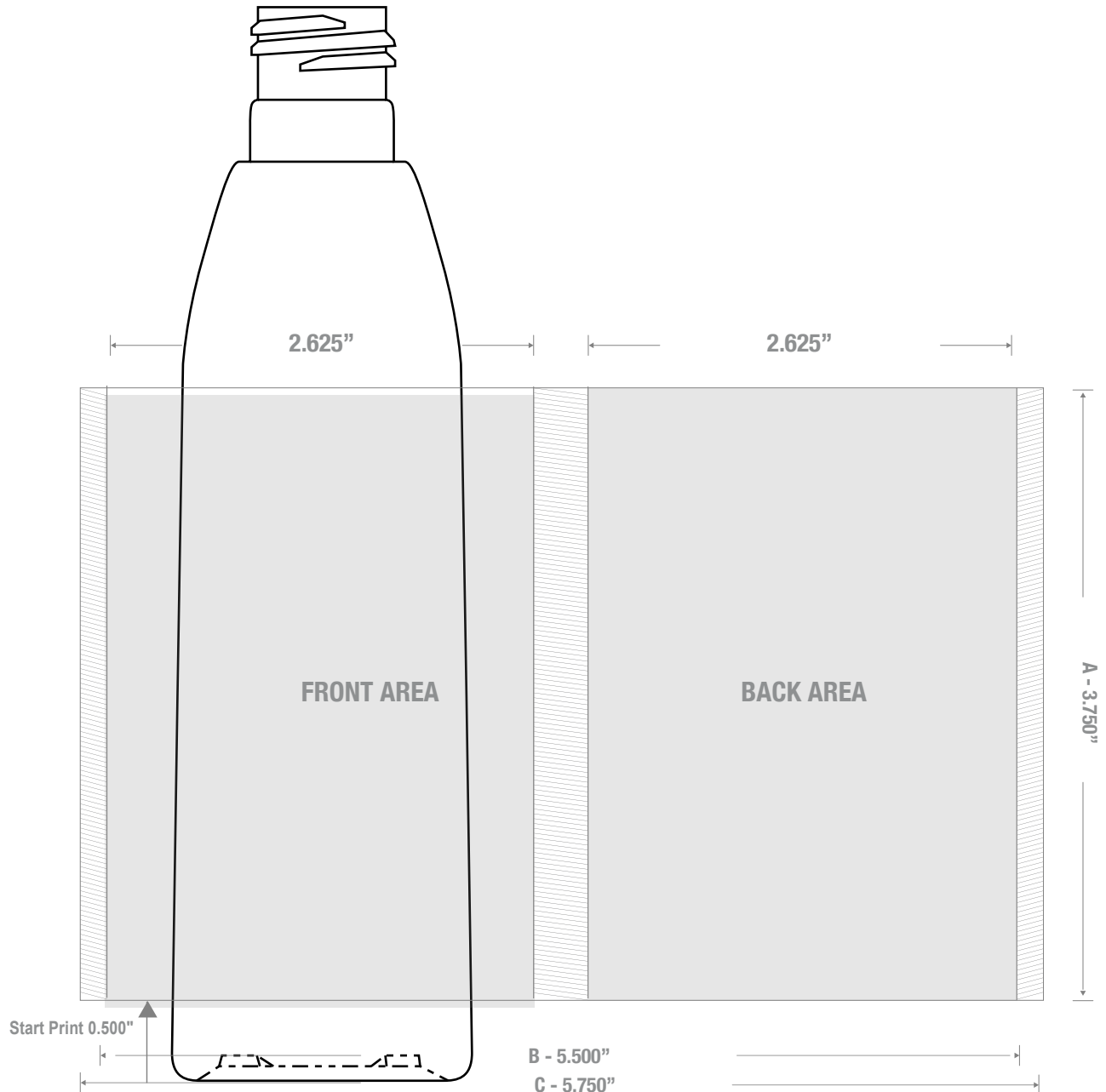

1700 S Hellman Ave, Ontario, California 91761  
 Phone: (909) 930-3610 | Fax: (909) 930-3640  
 e-mail: [info@classiccontainers.com](mailto:info@classiccontainers.com)  
[www.classiccontainers.com](http://www.classiccontainers.com)

**A - Total Height.**  
**B - Max. Decorating Area.**  
**C - Total bottle circumference.**  
 [Hatched Box] - Unprintable area.

# LABELING SPECIFICATIONS: 6 oz EVOLUTION 24/410



1700 S Hellman Ave, Ontario, California 91761  
Phone: (909) 930-3610 | Fax: (909) 930-3640  
e-mail: [info@classiccontainers.com](mailto:info@classiccontainers.com)  
[www.classiccontainers.com](http://www.classiccontainers.com)

**A - Total Height.**  
**B - Total bottle circumference.**