

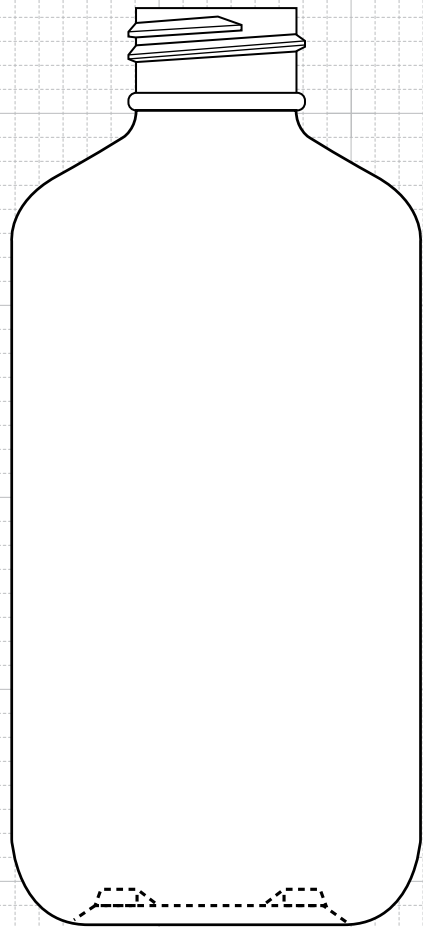

### FRONT VIEW



B

A

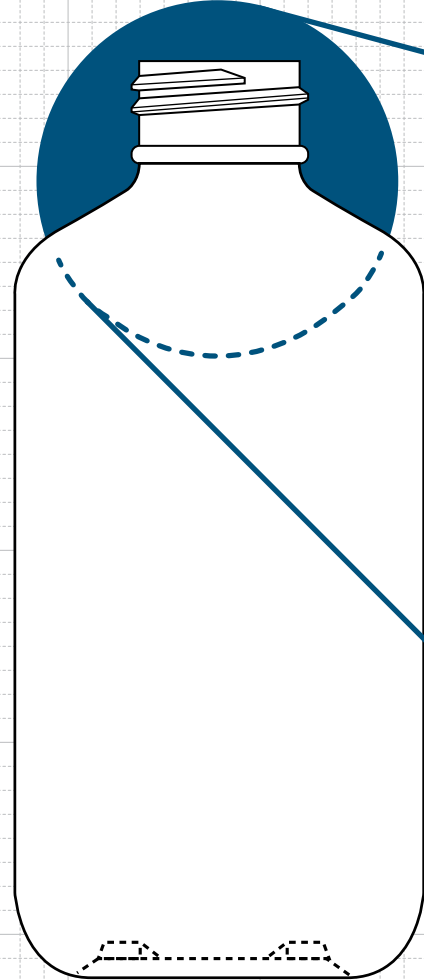

### NECK & THREAD DETAIL

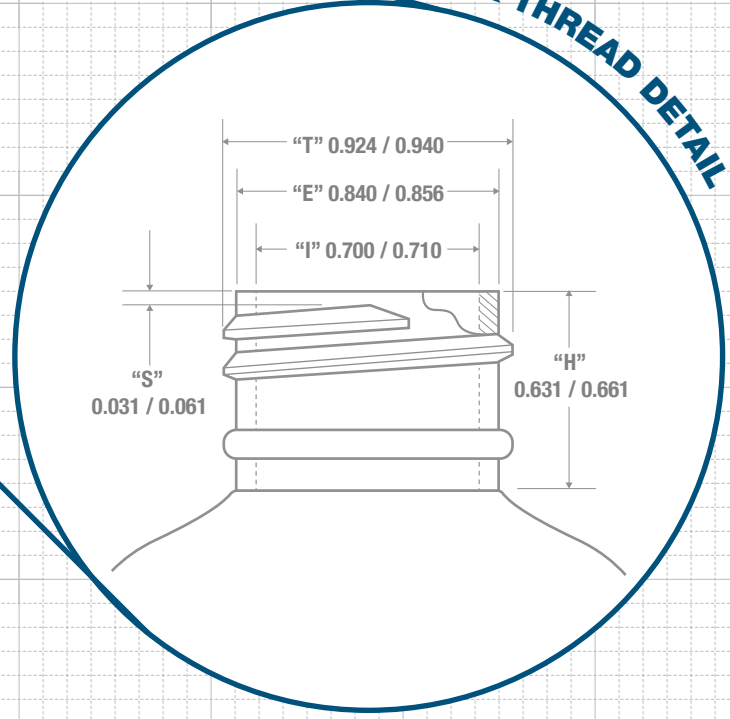

Drawing:  
6 oz Boston Round 24/410

Stock Code:  
000600060240000

Manufacturing Process:  
Extrusion Blow Molding

Overflow Capacity:  
203 - 215 ml (6.9 - 7.3 oz)

Gram Weight:  
17.0 ± 2

Neck Finish:  
24/410

Base Width (A):  
2.130 ± 0.050

Overall Height (B):  
4.776 ± 0.050

Max Print Area (Height):  
2.750"

Max Print Area (Width):  
6.500"

Case Pack: 520

Case Weight (lb): 22.4 ± 2.3

Cases Per Pallet: 16

Box Dimensions:  
24 7/16 x 18 1/2 x 23

Stock Material:

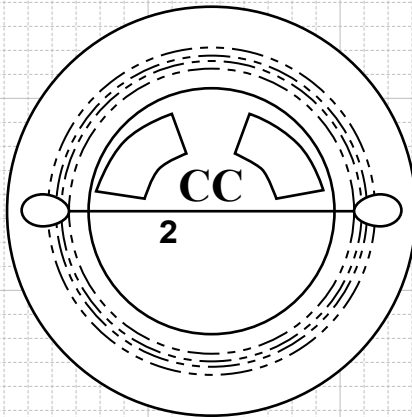

### BOTTOM VIEW

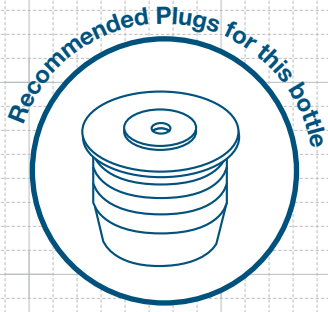

### FRICTION FIT

**CLASSIC CONTAINERS INC**  
1700 S. Hellman Ave.  
Ontario, CA 91761  
Phone: 909-930-3610  
e-mail: info@classiccontainers.com  
www.classiccontainers.com

# PRINTING SPECIFICATIONS: 6 oz BOSTON ROUND

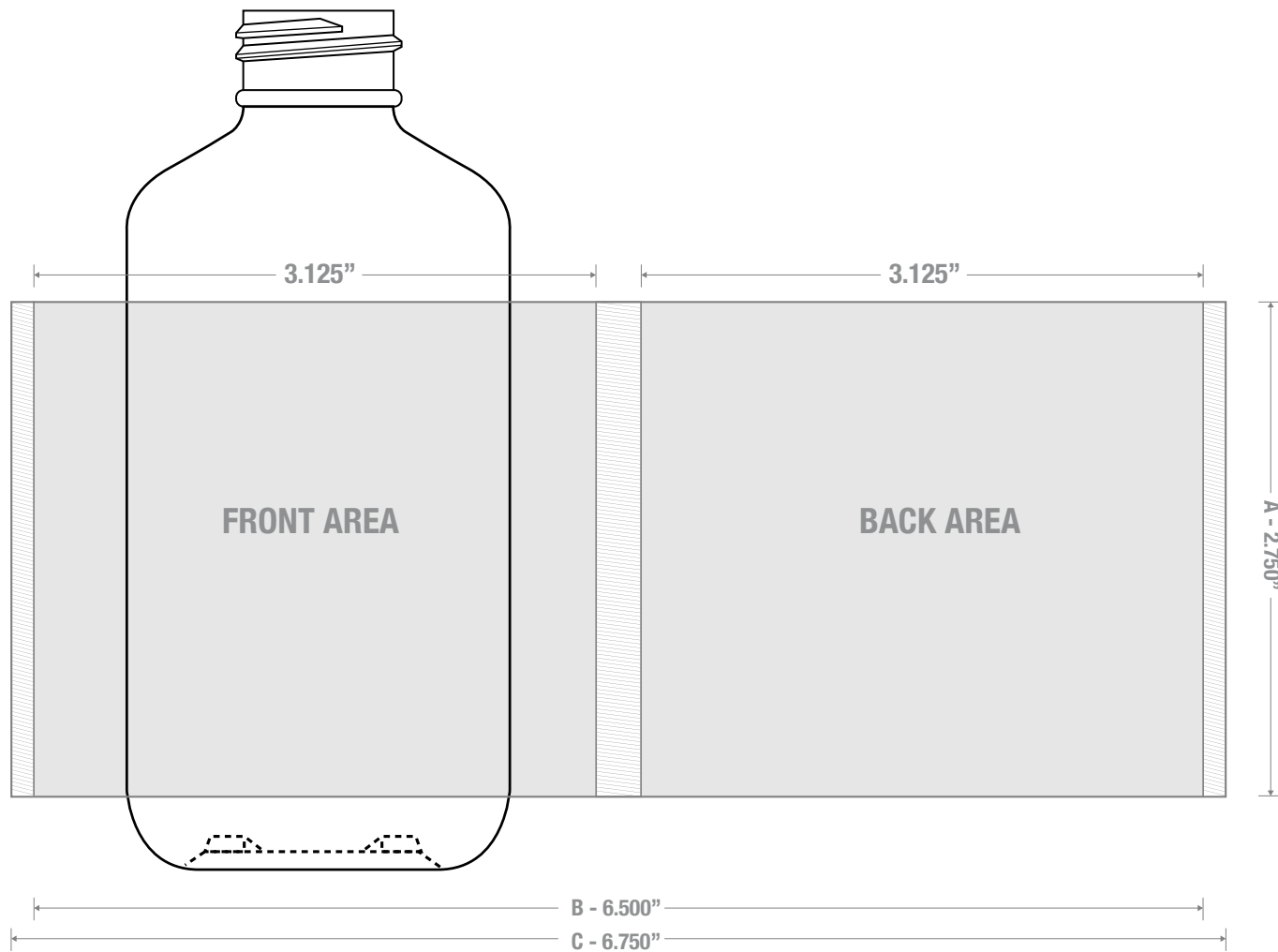

1700 S Hellman Ave, Ontario, California 91761  
Phone: (909) 930-3610 | Fax: (909) 930-3640  
e-mail: [info@classiccontainers.com](mailto:info@classiccontainers.com)  
[www.classiccontainers.com](http://www.classiccontainers.com)

**A - Total Height.**  
**B - Max. Decorating Area.**  
**C - Total bottle circumference.**  
▨ - Unprintable area.

# LABELING SPECIFICATIONS: 6 oz BOSTON ROUND

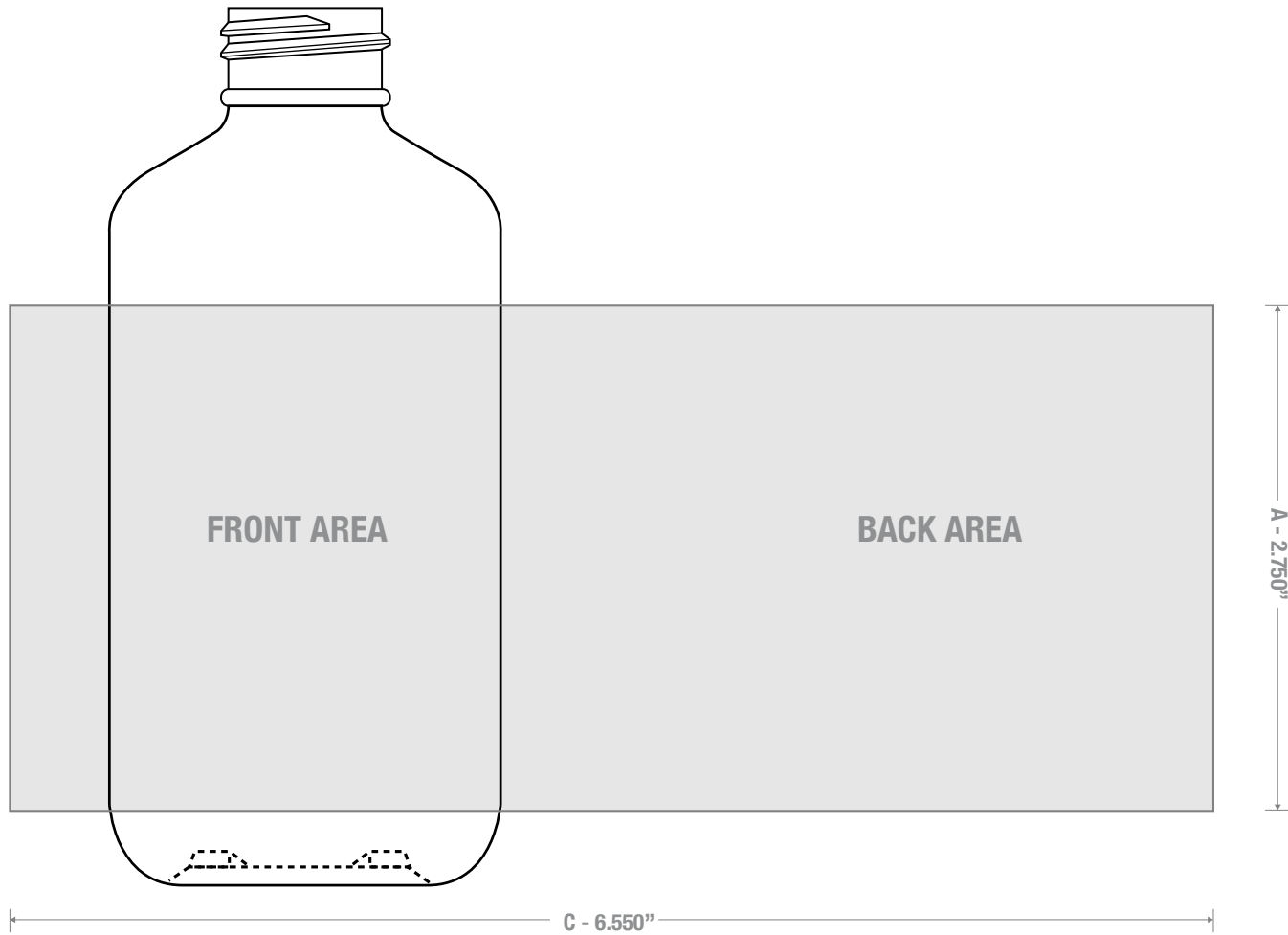

1700 S Hellman Ave, Ontario, California 91761  
Phone: (909) 930-3610 | Fax: (909) 930-3640  
e-mail: [info@classiccontainers.com](mailto:info@classiccontainers.com)  
[www.classiccontainers.com](http://www.classiccontainers.com)

**A - Total Height.**  
**B - Max. Decorating Area.**