



Drawing:
5 oz Royalty Round 24/410

Stock Code:
000500040240000

Manufacturing Process:
Extrusion Blow Molding

Overflow Capacity:
150 - 162 ml (5.1 - 5.5 oz)

Gram Weight:
16 ± 1

Neck Finish:
24/410

Base Width (A):
1.690 ± 0.050

Overall Height (B):
5.365 ± 0.050

Max Print Area (Height):
3.750"

Max Print Area (Width):
5.062"

Case Pack: **405**

Case Weight (lb): **16.4 ± 0.9**

Cases Per Pallet: **25**

Box Dimensions:
23 5/8 x 15 9/16 x 17

Stock Material:



CLASSIC CONTAINERS INC
1700 S. Hellman Ave.
Ontario, CA 91761
Phone: 909-930-3610
e-mail: info@classiccontainers.com
www.classiccontainers.com

FRONT VIEW

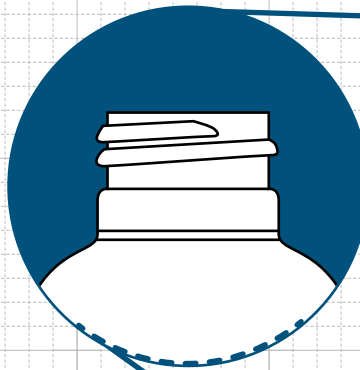
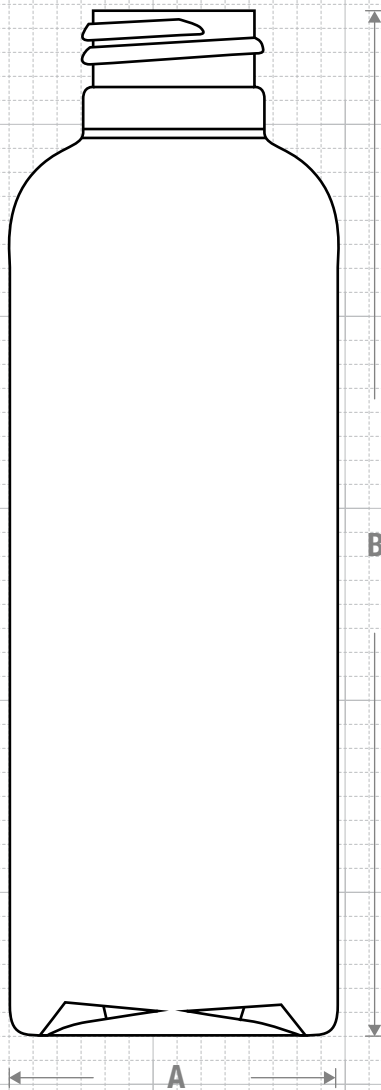

NECK & THREAD DETAIL

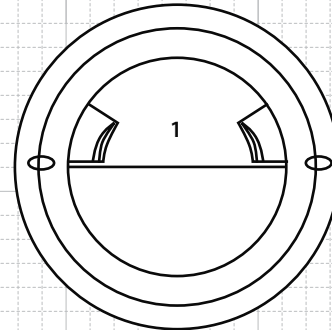
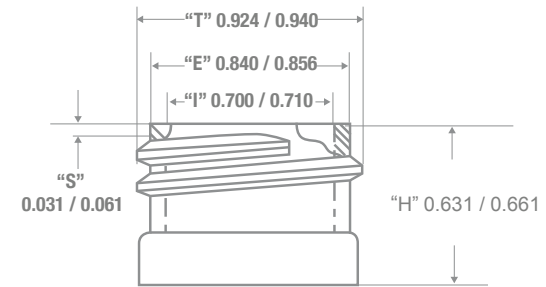

BOTTOM VIEW

Recommended Plugs for this bottle



FRICTION FIT

PRINTING SPECIFICATIONS: 5 oz Royalty Round 24/410

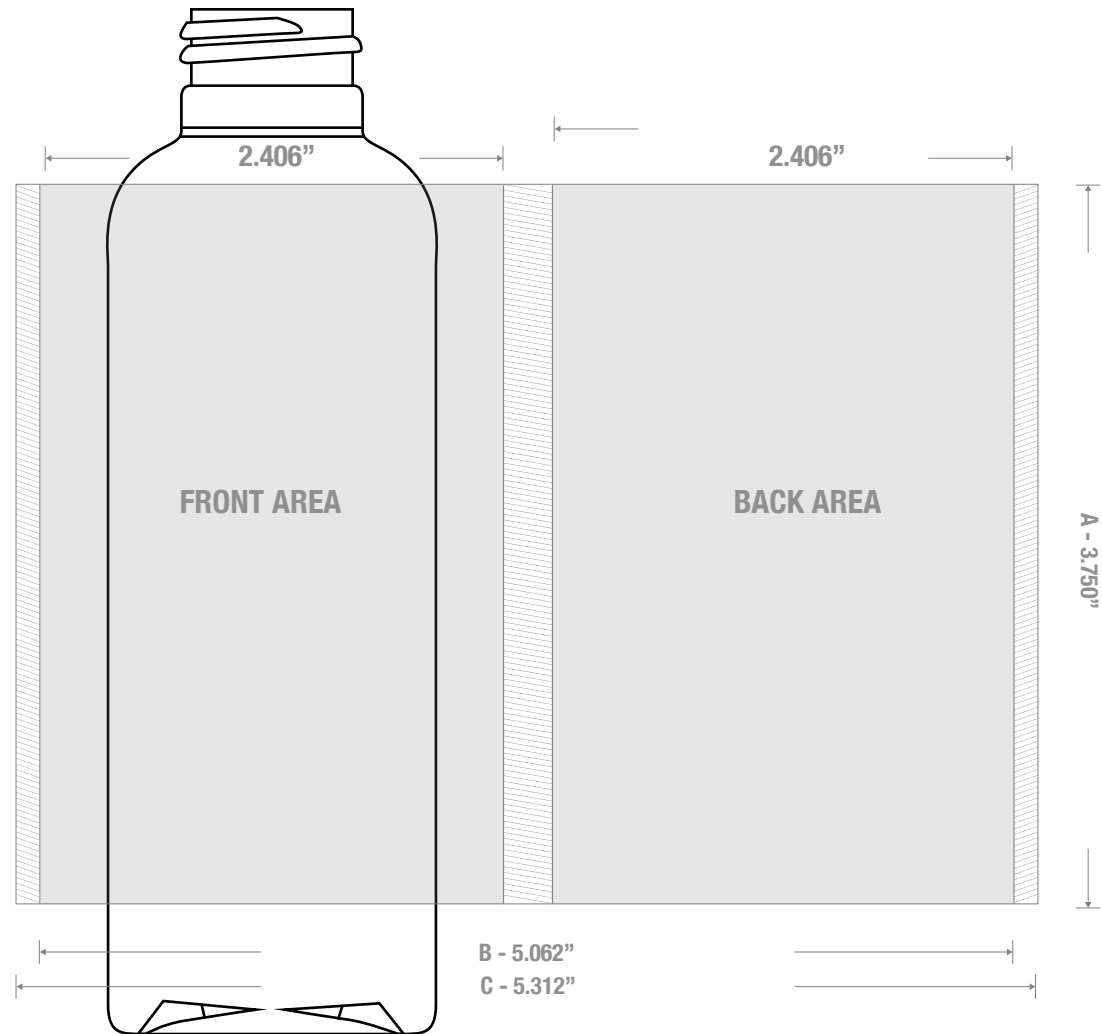

1700 S Hellman Ave, Ontario, California 91761
Phone: (909) 930-3610 | Fax: (909) 930-3640
e-mail: info@classiccontainers.com
www.classiccontainers.com

A - Total Height.
B - Max. Decorating Area.
C - Total bottle circumference.
▨ - Unprintable area.

LABELING SPECIFICATIONS: 5 oz Royalty Round 24/410

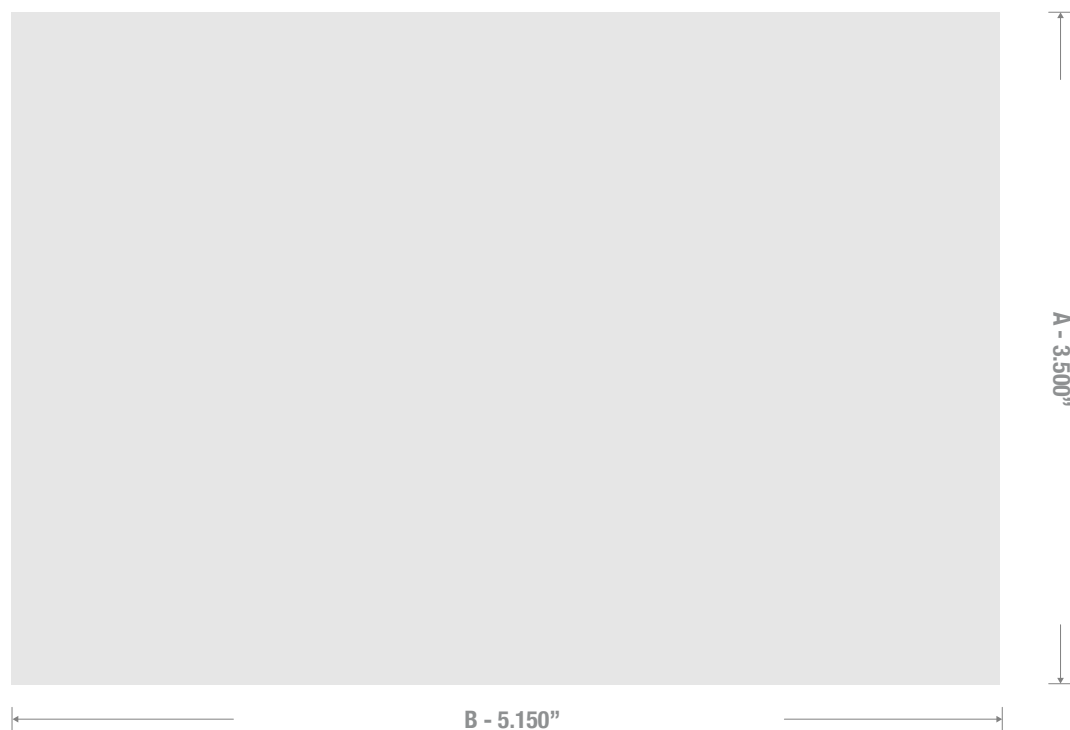

1700 S Hellman Ave, Ontario, California 91761
Phone: (909) 930-3610 | Fax: (909) 930-3640
e-mail: info@classiccontainers.com
www.classiccontainers.com

A - Total Height.
B - Total bottle circumference.