



Drawing:
5 oz Cylinder Round 24/410

Stock Code:
000500010240000

Manufacturing Process:
Extrusion Blow Molding

Overflow Capacity:
156 - 168 ml (5.3 - 5.7 oz)

Gram Weight:
16 ± 1

Neck Finish:
24/410

Base Width (A):
1.608 ± 0.050

Overall Height (B):
5.958 ± 0.050

Max Print Area (Height):
4.650"

Max Print Area (Width):
4.820"

Case Pack: 408

Case Weight (lb): 16.5 ± 0.9

Cases Per Pallet: 25

Box Dimensions:
24 7/16 x 18 1/2 x 23

Stock Material:



CLASSIC CONTAINERS INC
1700 S. Hellman Ave.
Ontario, CA 91761
Phone: 909-930-3610
e-mail: info@classiccontainers.com
www.classiccontainers.com

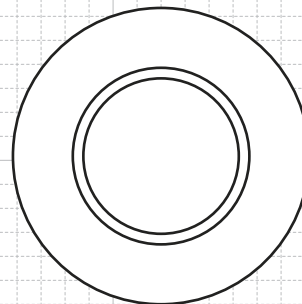
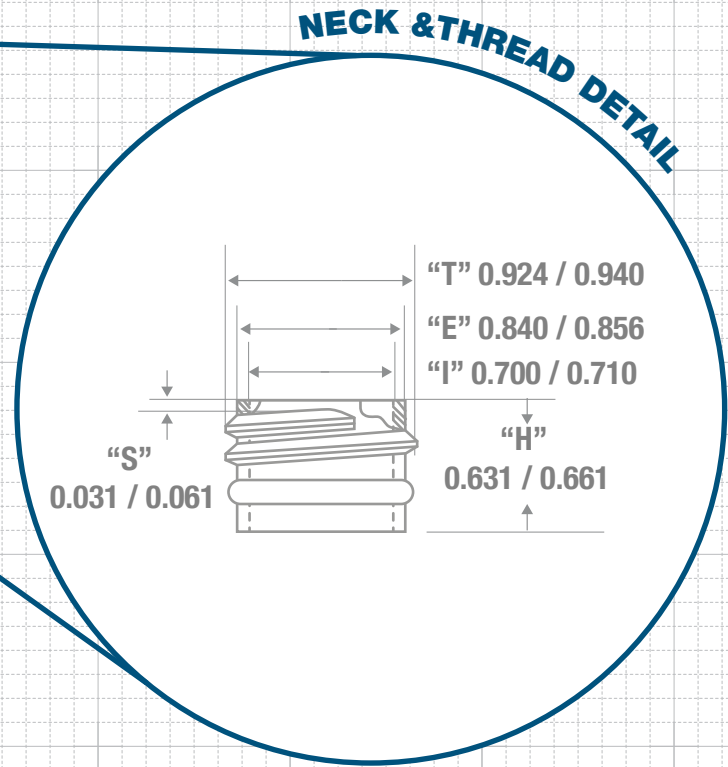
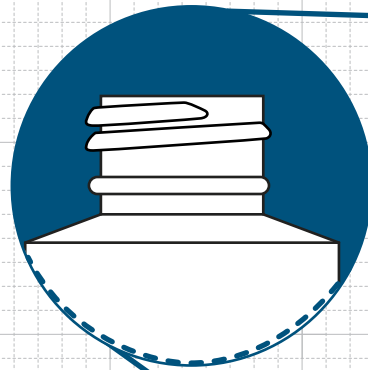
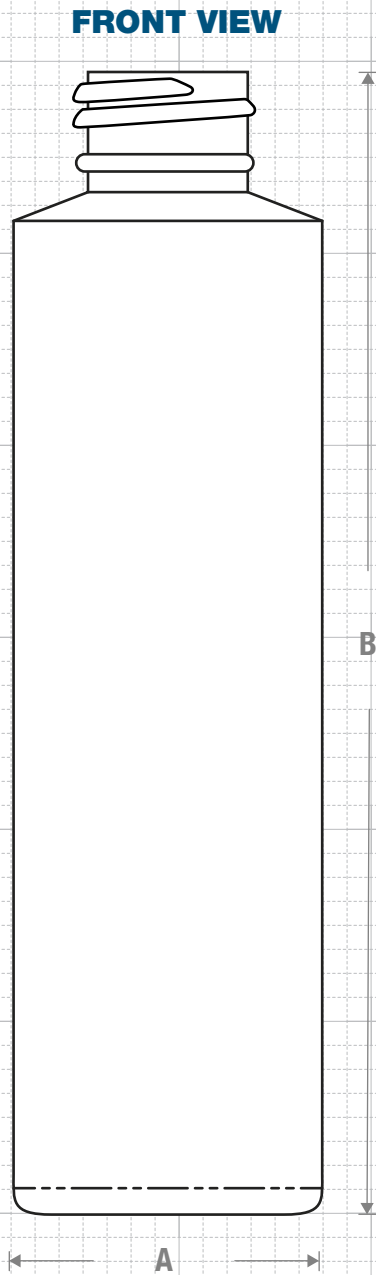

TOP VIEW

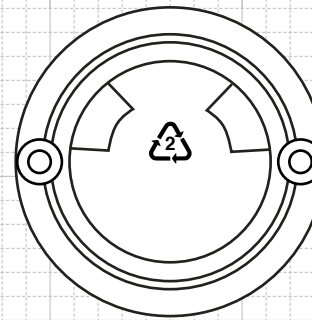

BOTTOM VIEW

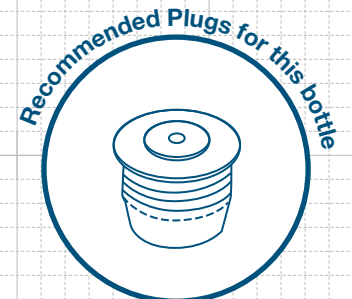

FRICITION FIT

PRINTING SPECIFICATIONS: 5 oz CYLINDER ROUND 24/410

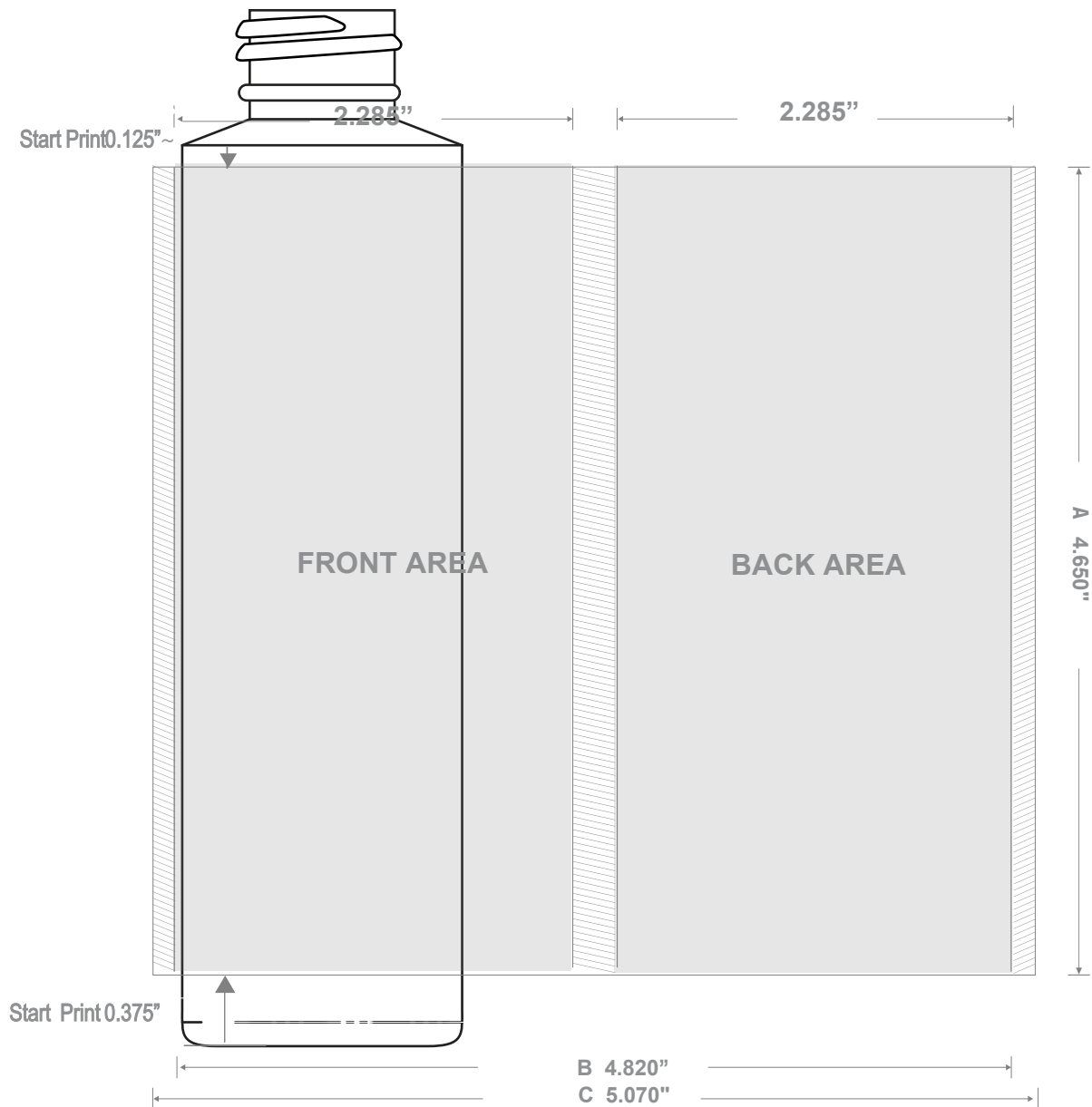

1700 S Hellman Ave, Ontario, California 91761
 Phone: (909) 930-3610 | Fax: (909) 930-3640
 e-mail: info@classiccontainers.com
www.classiccontainers.com

A - Total Height.
B - Max. Decorating Area.
C - Total bottle circumference.
 [Hatched Box] - Unprintable area.

LABELING SPECIFICATIONS: 5 oz CYLINDER ROUND 24/410

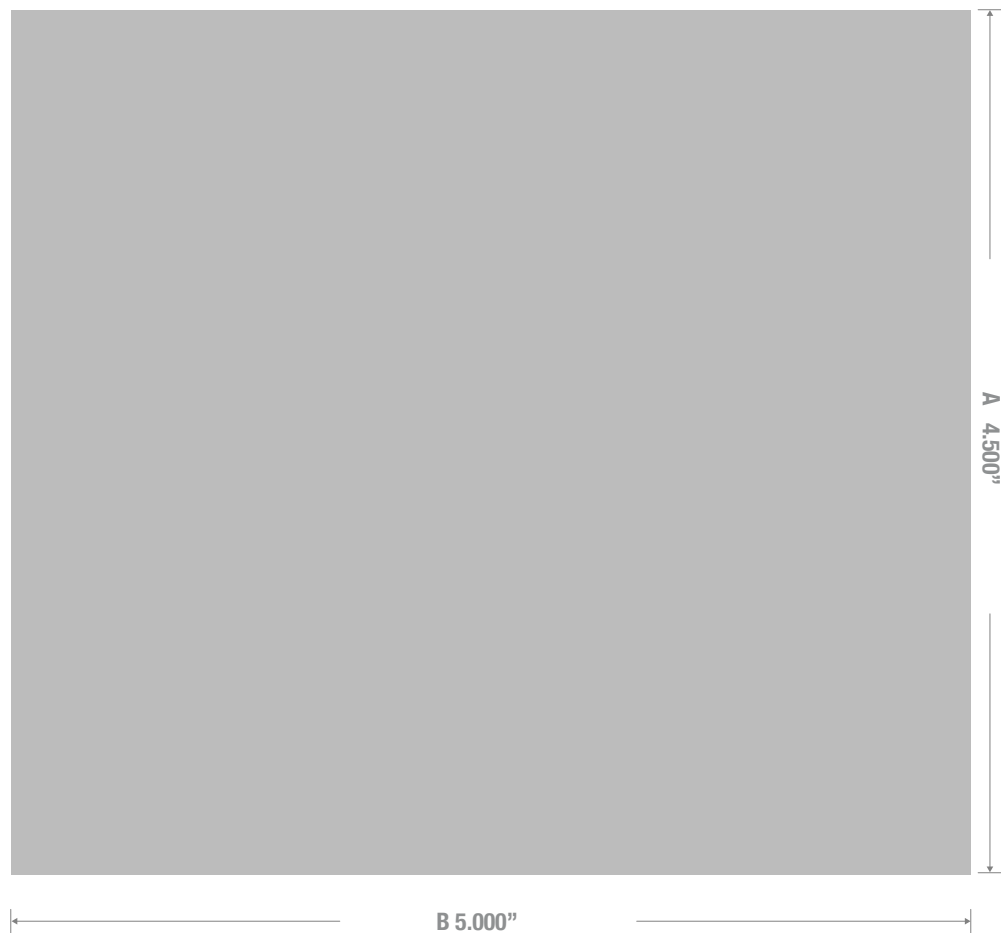

1700 S Hellman Ave, Ontario, California 91761
Phone: (909) 930-3610 | Fax: (909) 930-3640
e-mail: info@classiccontainers.com
www.classiccontainers.com

A - Total Height.
B - Total bottle circumference.