

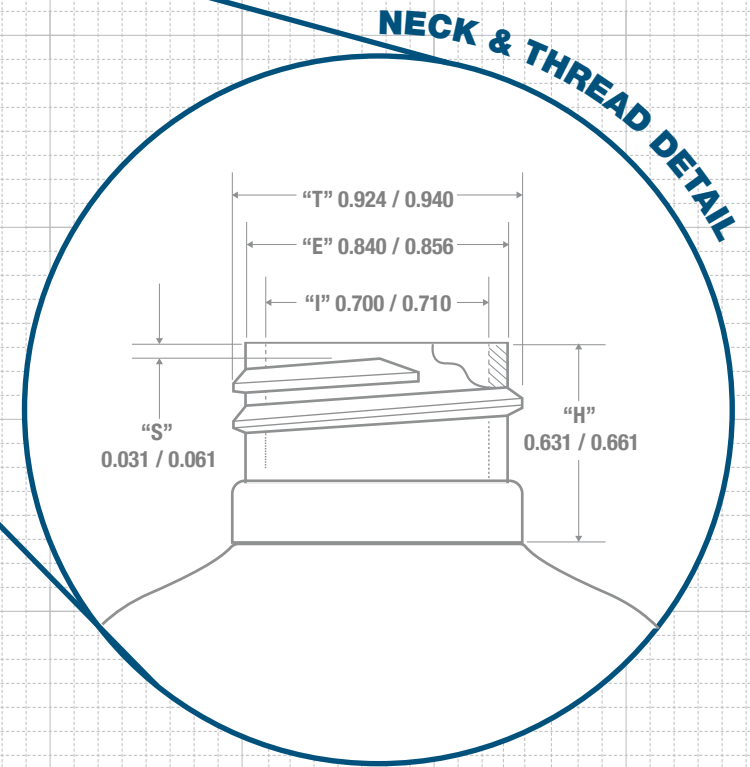

FRONT VIEW

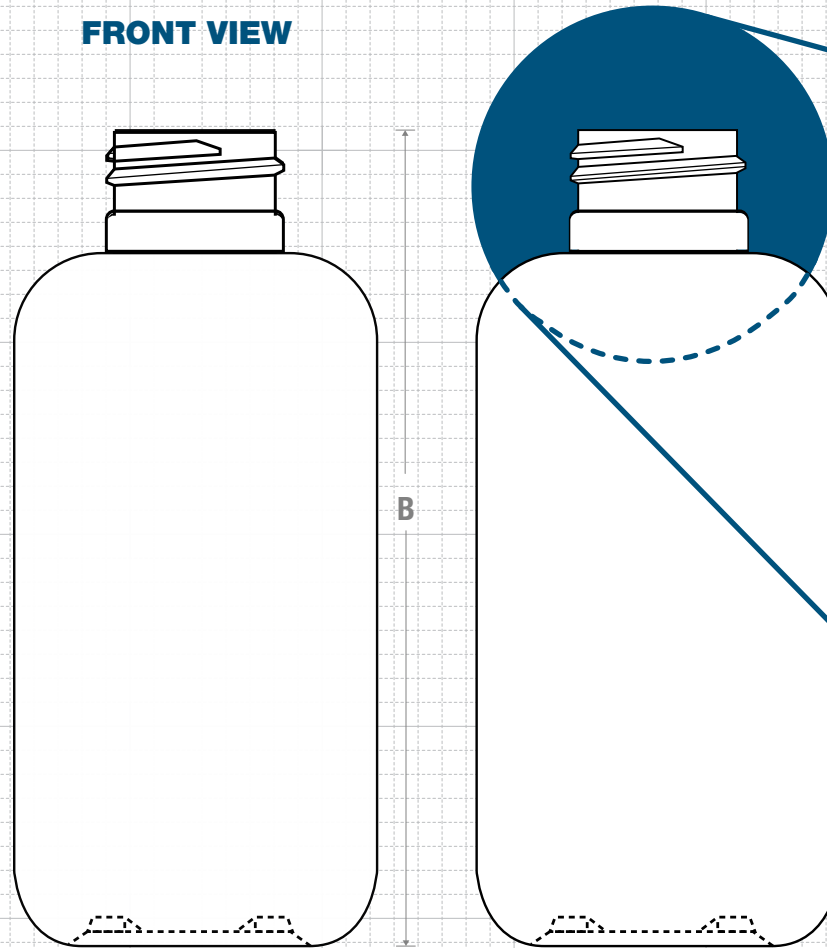

Drawing:
5 oz Boston Round 24/410 M2

Stock Code:
0005000602400M2

Manufacturing Process:
Extrusion Blow Molding

Overflow Capacity:
150.5 - 162 ml (5.1 - 5.5 oz)

Gram Weight:
13.5 ± 1

Neck Finish:
24/410

Base Width (A):
1.890 ± 0.050

Overall Height (B):
4.250 ± 0.050

Max Print Area (Height):
2.600"

Max Print Area (Width):
5.750"

Case Pack: **660**

Case Weight (lb): **23 ± 1.0**

Cases Per Pallet: **16**

Box Dimensions:
24 7/16 x 18 1/2 x 23

Stock Material:

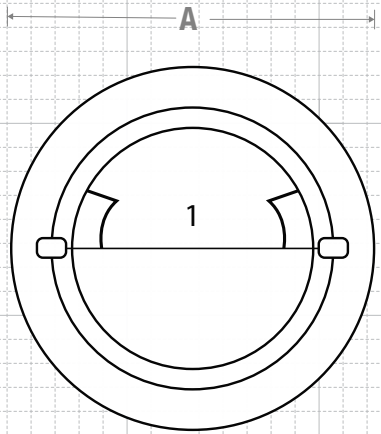

BOTTOM VIEW

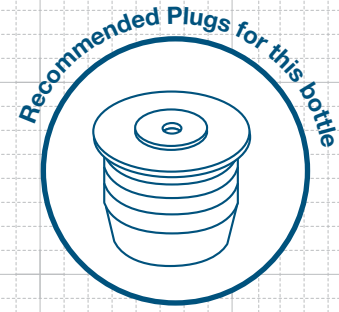

FRICTION FIT

CLASSIC CONTAINERS INC
1700 S. Hellman Ave.
Ontario, CA 91761
Phone: 909-930-3610
e-mail: info@classiccontainers.com
www.classiccontainers.com

PRINTING SPECIFICATIONS: 5 oz BOSTON ROUND M2

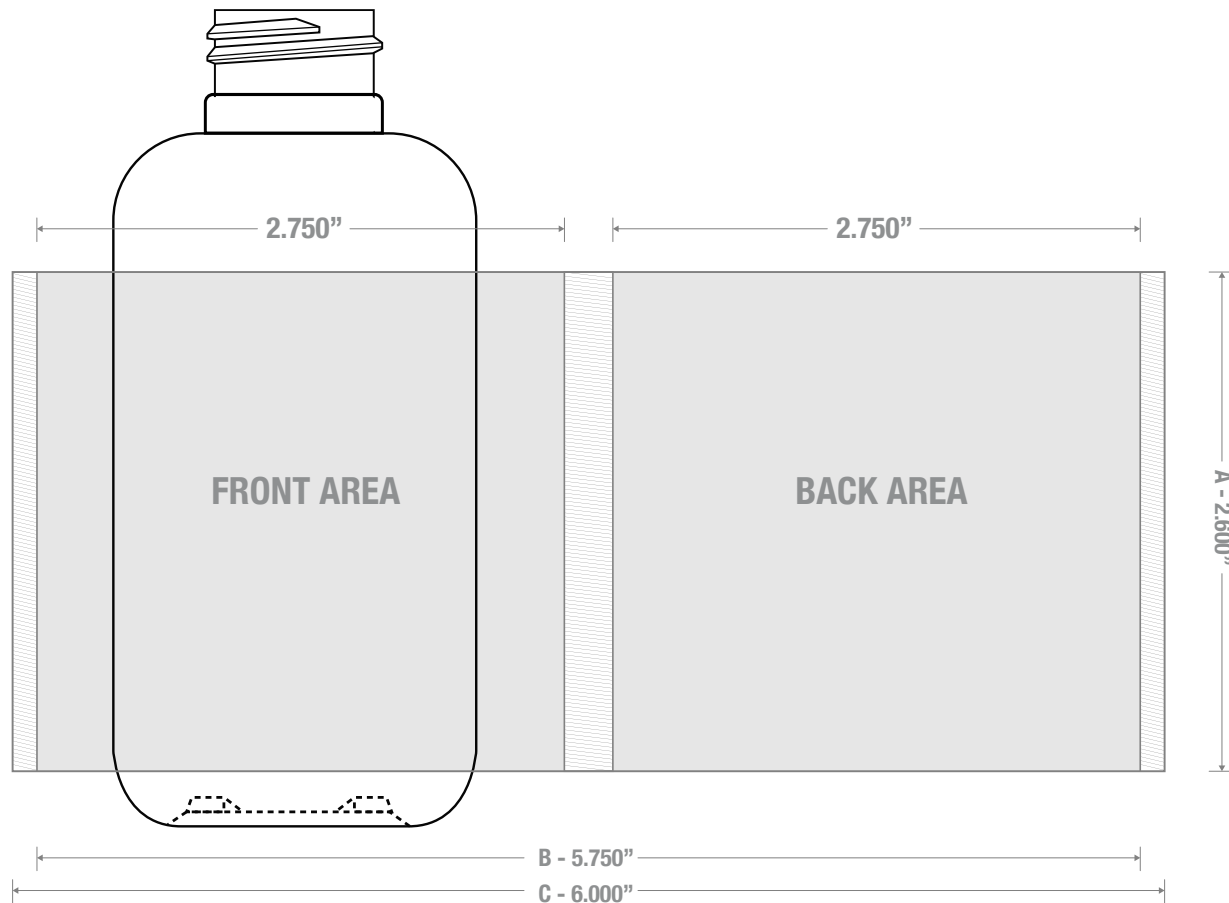

1700 S Hellman Ave, Ontario, California 91761
Phone: (909) 930-3610 | Fax: (909) 930-3640
e-mail: info@classiccontainers.com
www.classiccontainers.com

A - Total Height.
B - Max. Decorating Area.
C - Total bottle circumference.
▨ - Unprintable area.