

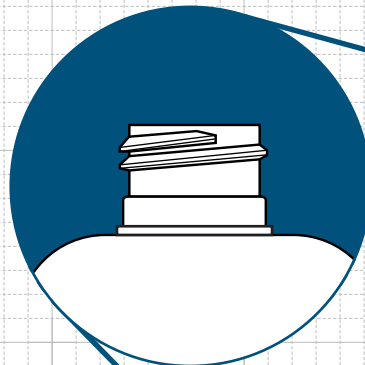

FRONT VIEW

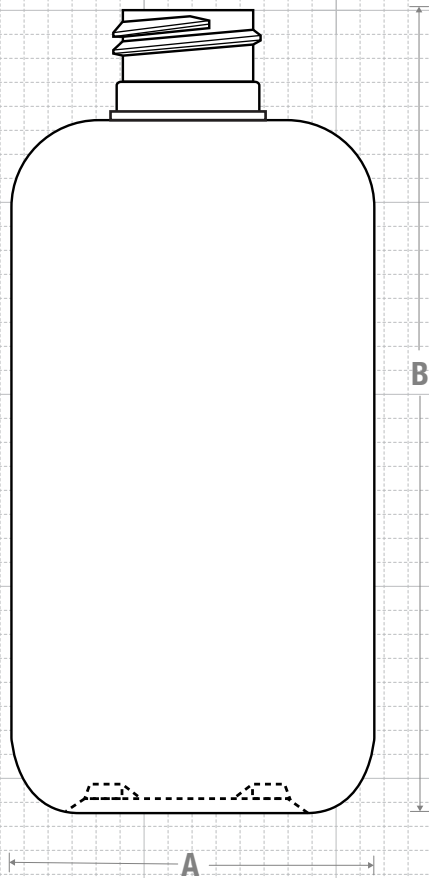

NECK & THREAD DETAIL

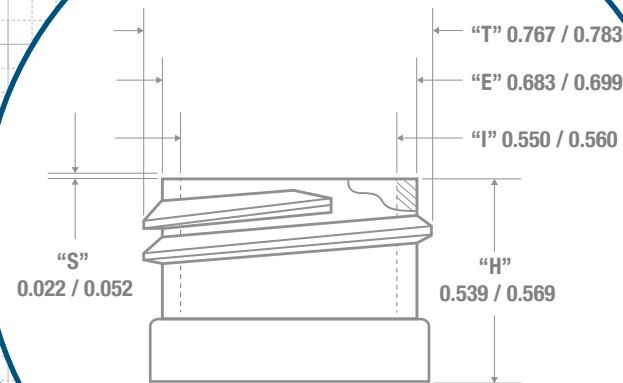

Drawing:
5 oz Boston Round 20/410 M2

Stock Code:
0005000602000M2

Manufacturing Process:
Extrusion Blow Molding

Overflow Capacity:
148 - 159 ml (5.0 - 5.5 oz)

Gram Weight:
13.5 ± 1

Neck Finish:
20/410

Base Width (A):
1.890 ± 0.050

Overall Height (B):
4.228 ± 0.050

Max Print Area (Height):
2.600"

Max Print Area (Width):
5.750"

Case Pack: **403**

Case Weight (lb): **14.1 ± 0.9**

Cases Per Pallet: **25**

Box Dimensions:
23 5/8 X 15 9/10 X 17

Stock Material:

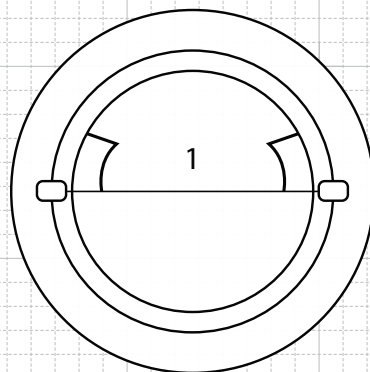

BOTTOM VIEW

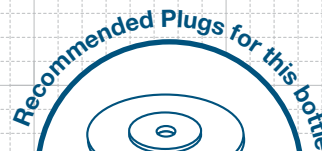

FRICION FIT

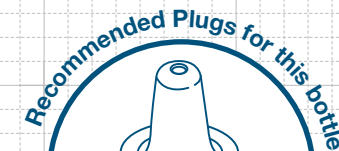

FRICION FIT

CLASSIC CONTAINERS INC
1700 S. Hellman Ave.
Ontario, CA 91761
Phone: 909-930-3610
e-mail: info@classiccontainers.com
www.classiccontainers.com

PRINTING SPECIFICATIONS: 5 oz BOSTON ROUND M2

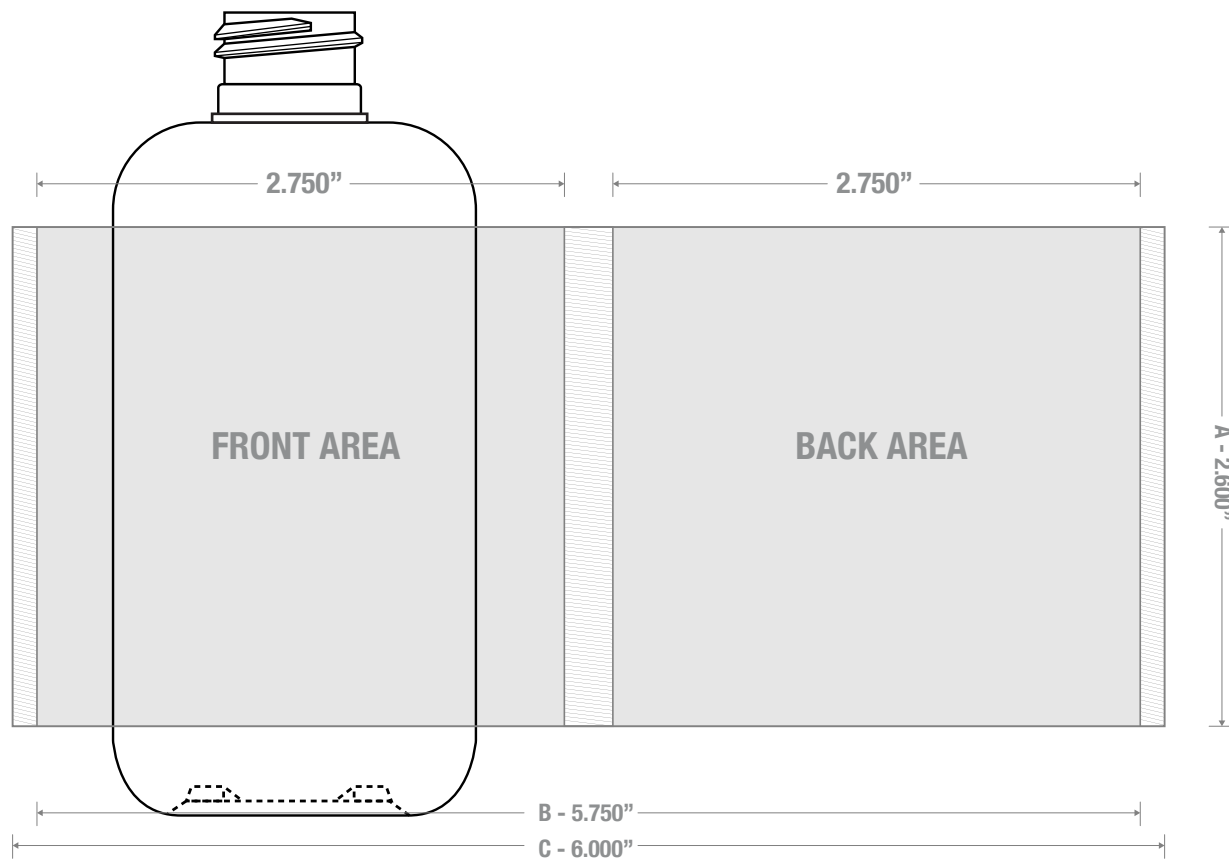

1700 S Hellman Ave, Ontario, California 91761
Phone: (909) 930-3610 | Fax: (909) 930-3640
e-mail: info@classiccontainers.com
www.classiccontainers.com

A - Total Height.
B - Max. Decorating Area.
C - Total bottle circumference.
▨ - Unprintable area.