



Drawing:  
4 oz Imperial Round  
24/410

Stock Code:  
000400050240000

Manufacturing Process:  
Extrusion Blow Molding

Overflow Capacity:  
121.0-133 ml (4.1 - 4.5 oz)

Gram Weight:  
13.0 ± 1

Neck Finish:  
24/410

Base Width (A):  
1.510 ± 0.050

Overall Height (B):  
5.375± 0.050

Max Print Area (Height):  
3.750

Max Print Area (Width):  
4.500"

Case Pack: 522

Case Weight (lb): 17.0± 1.2

Cases Per Pallet: 25

Box Dimensions:  
23 5/8 x15 9/16 x17

Stock Material:



**CLASSIC CONTAINERS INC**  
1700 S. Hellman Ave.  
Ontario, CA 91761  
Phone: 909-930-3610  
e-mail: info@classiccontainers.com  
www.classiccontainers.com

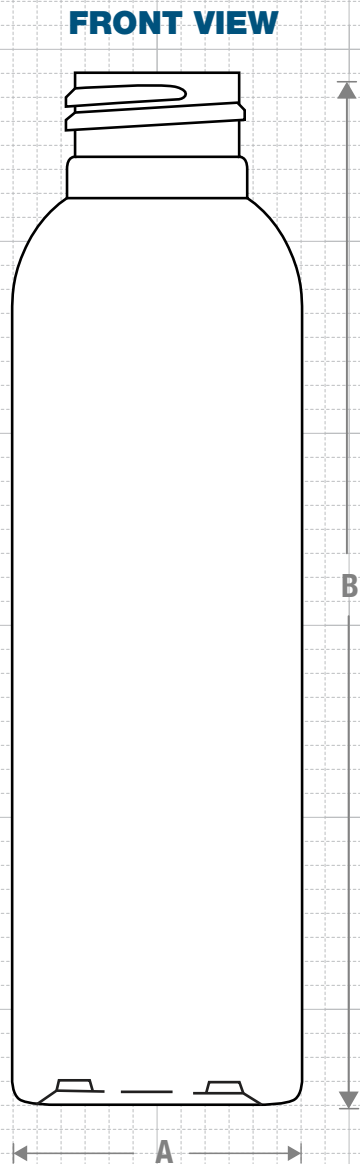

**FRONT VIEW**

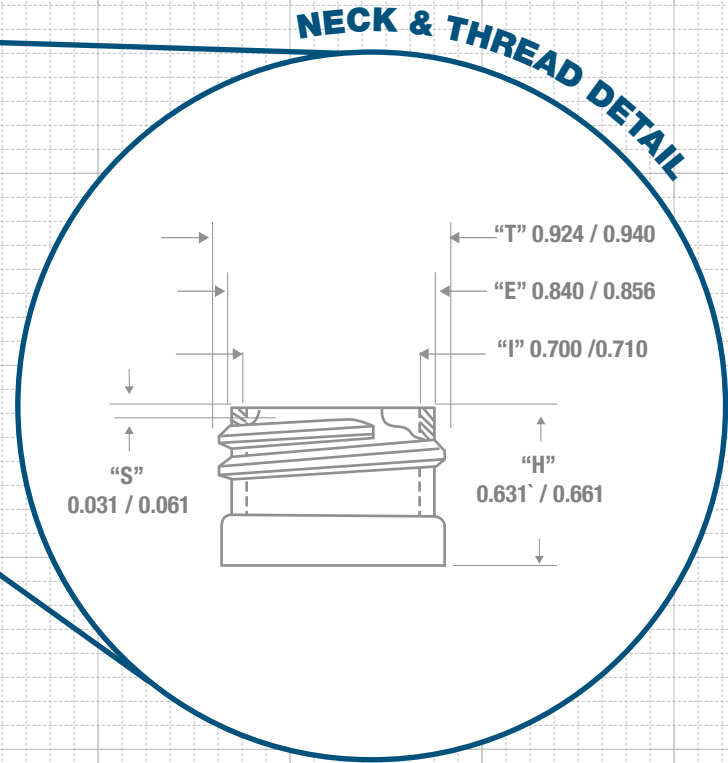
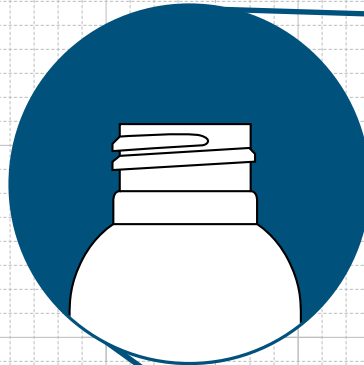

**NECK & THREAD DETAIL**

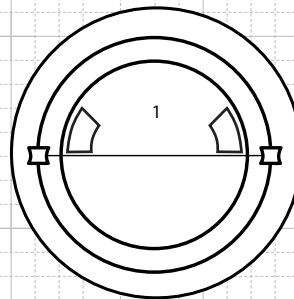

**BOTTOM VIEW**

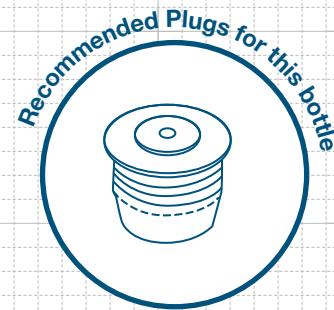

**FRICTION FIT**

# PRINTING SPECIFICATIONS: 4 oz IMPERIAL ROUND 24/410

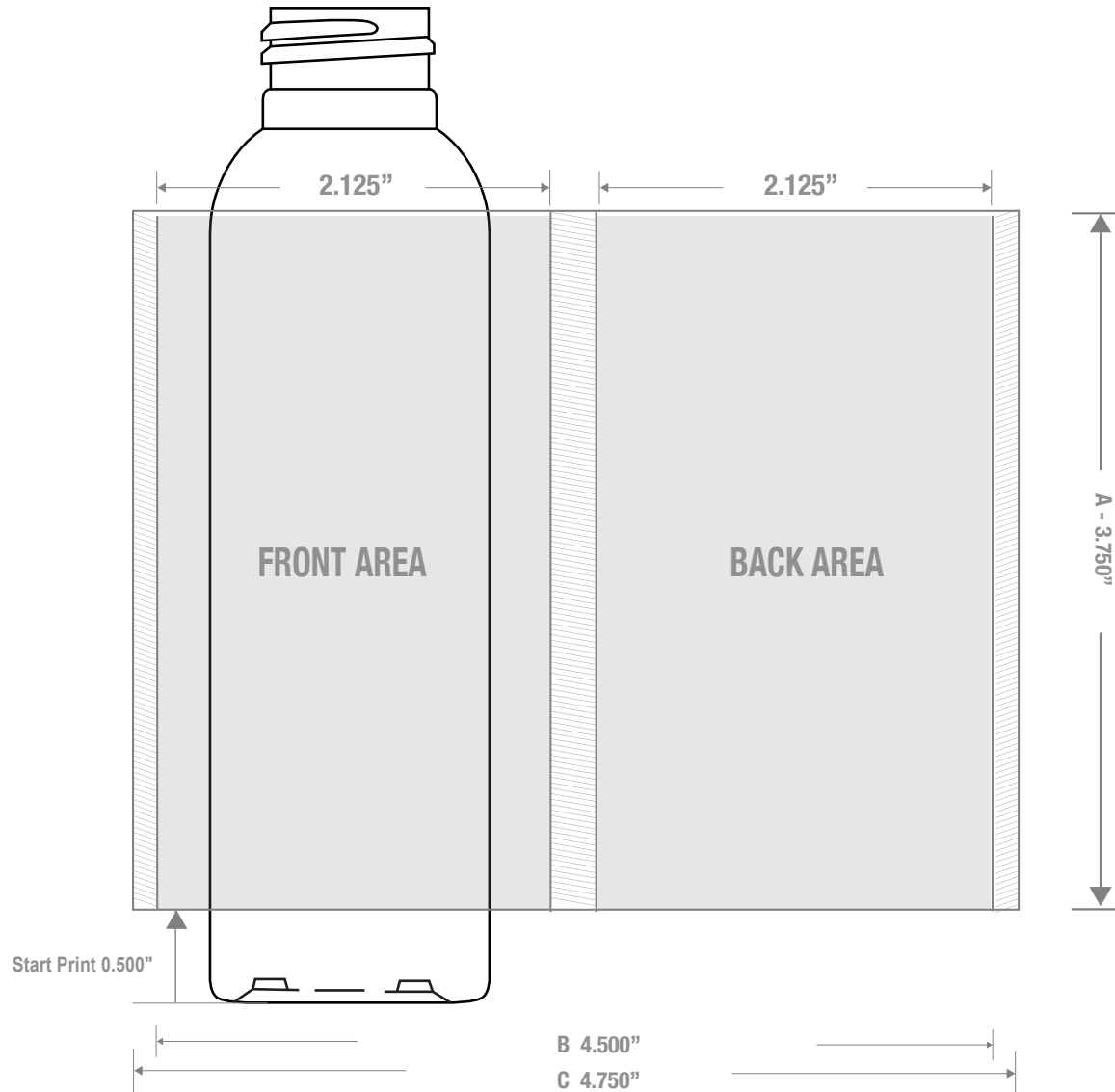

1700 S Hellman Ave, Ontario, California 91761  
Phone: (909) 930-3610 | Fax: (909) 930-3640  
e-mail: [info@classiccontainers.com](mailto:info@classiccontainers.com)  
[www.classiccontainers.com](http://www.classiccontainers.com)

A - Total Height.  
B - Max. Decorating Area.  
C - Total bottle circumference.  
▨ - Unprintable area.

# LABELING SPECIFICATIONS: 4 oz IMPERIAL ROUND 24/410



1700 S Hellman Ave, Ontario, California 91761  
Phone: (909) 930-3610 | Fax: (909) 930-3640  
e-mail: [info@classiccontainers.com](mailto:info@classiccontainers.com)  
[www.classiccontainers.com](http://www.classiccontainers.com)

**A - Total Height.**  
**B - Max. Decorating Area.**  
**C - Total bottle circumference.**  
☐ - Unprintable area.