



Drawing:
4 oz Evolution 24/415

Stock Code:
000400330250000

Manufacturing Process:
Extrusion Blow Molding

Overflow Capacity:
133.0 - 145.0 ml (4.5- 4.9oz)

Gram Weight:
14 ± 1

Neck Finish:
24/415

Base Width (A):
1.580 ± 0.050

Overall Height (B):
5.687 ± 0.050

Max Print Area (Height):
3.250"

Max Print Area (Width):
4.750"

Case Pack: 480

Case Weight (lb): 16.9 ± 1.0

Cases Per Pallet: 25

Box Dimensions:
23 5/8 x 15 9/16 x 17

Stock Material:



CLASSIC CONTAINERS INC
1700 S. Hellman Ave.
Ontario, CA 91761
Phone: 909-930-3610
e-mail: info@classiccontainers.com
www.classiccontainers.com

FRONT VIEW

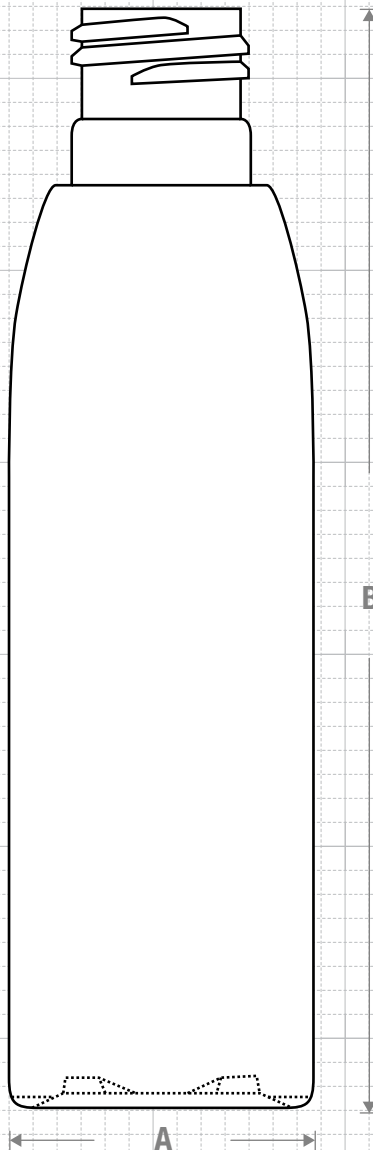

NECK & THREAD DETAIL

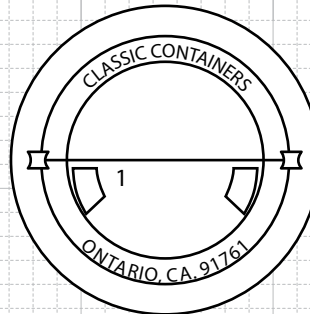
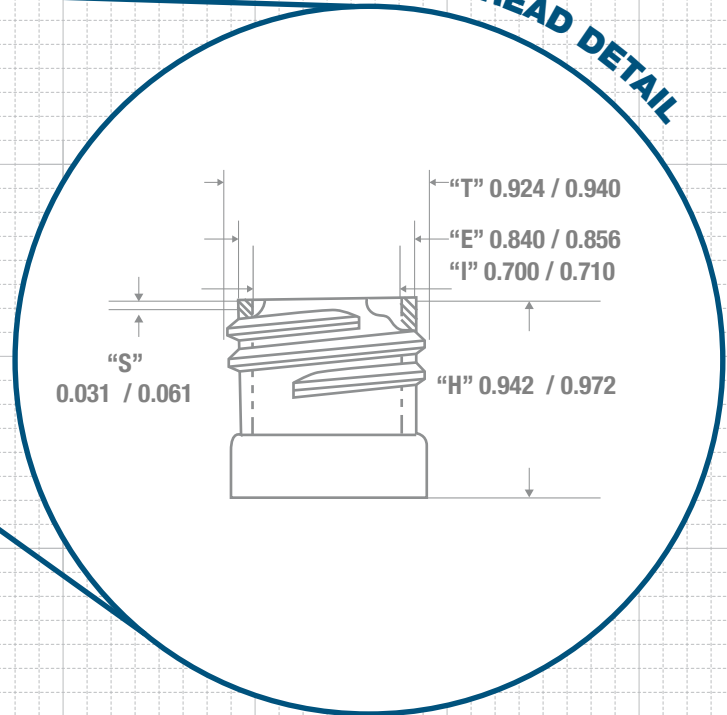

BOTTOM VIEW

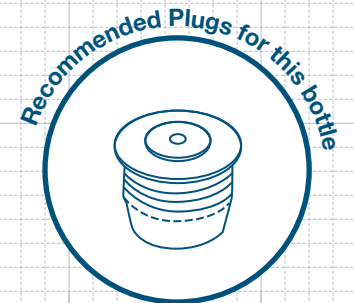

FRICITION FIT

Other Material Options

Stock Material: **HD/ST**
Case Pack: **462**
Case Weight (lb): **16.4 ± 1**



PRINTING SPECIFICATIONS: 4 oz EVOLUTION 24/415

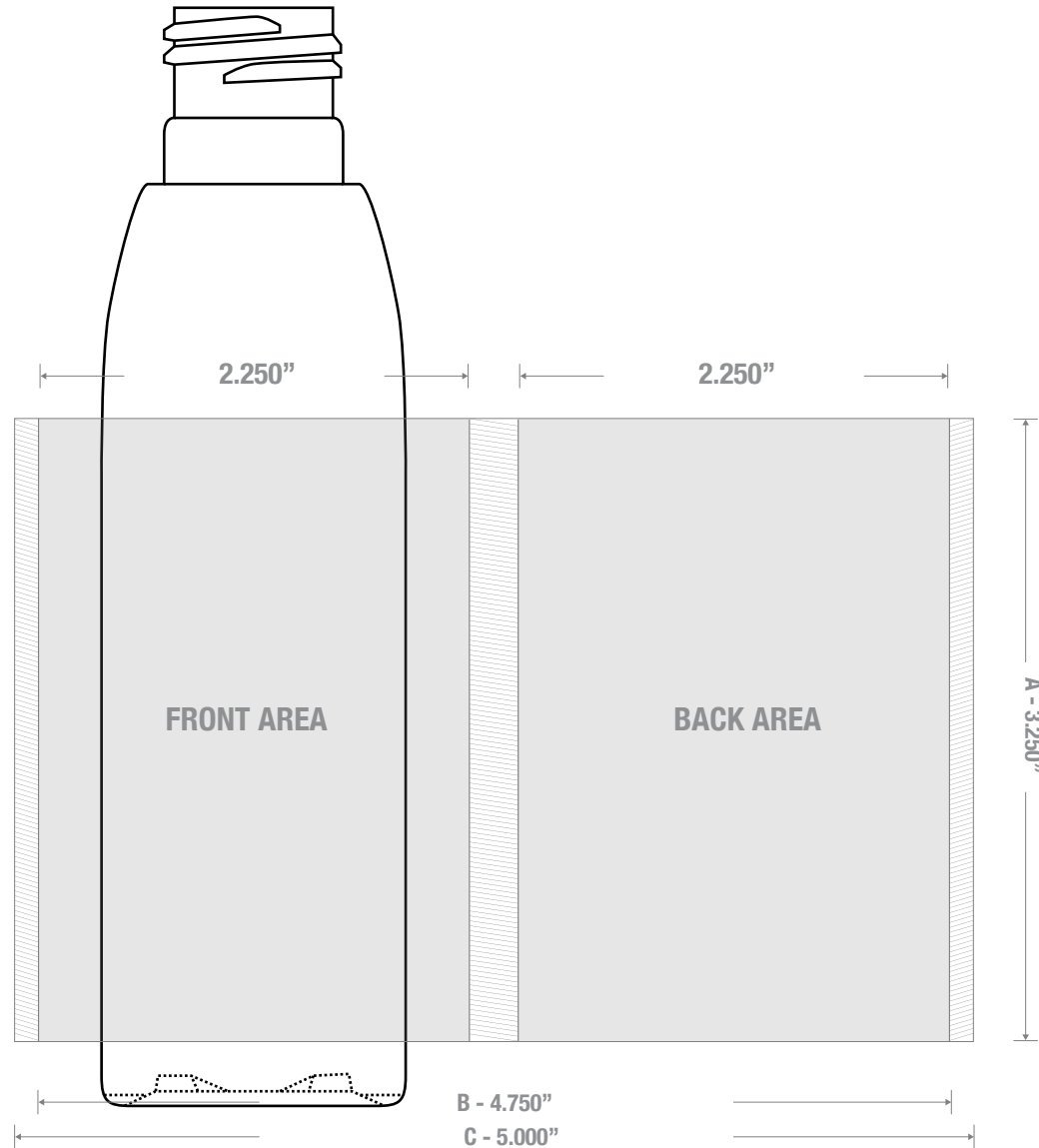

1700 S Hellman Ave, Ontario, California 91761
Phone: (909) 930-3610 | Fax: (909) 930-3640
e-mail: info@classiccontainers.com
www.classiccontainers.com

A - Total Height.
B - Max. Decorating Area.
C - Total bottle circumference.
▨ - Unprintable area.

LABELING SPECIFICATIONS: 4 oz EVOLUTION 24/415

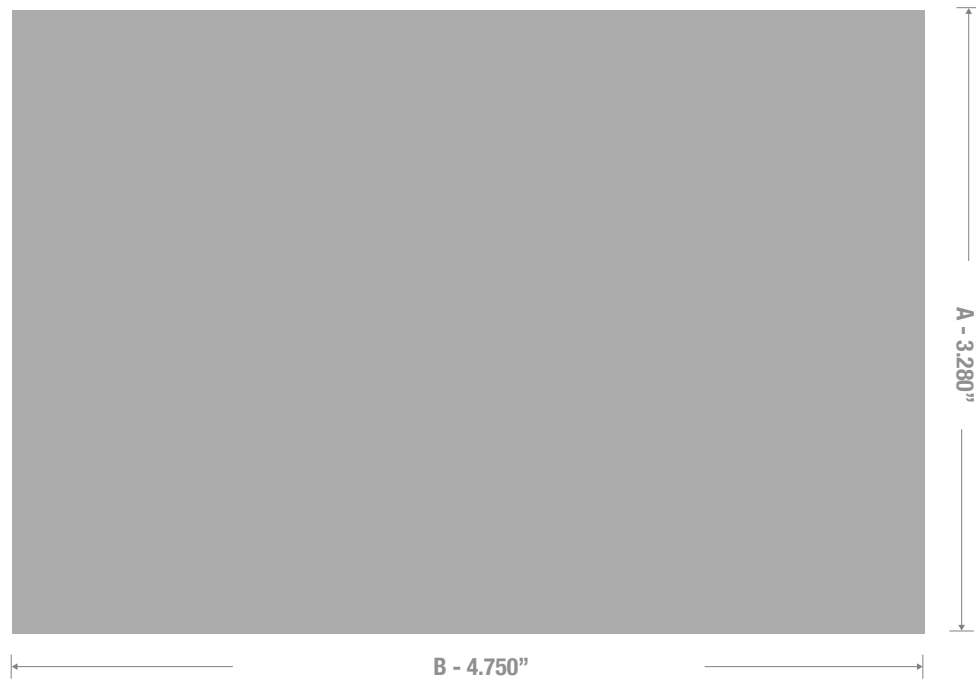

1700 S Hellman Ave, Ontario, California 91761
Phone: (909) 930-3610 | Fax: (909) 930-3640
e-mail: info@classiccontainers.com
www.classiccontainers.com

A - Total Height.
B - Total bottle circumference.