



Drawing:  
4 oz Evolution 24/410

Stock Code:  
000400330240000

Manufacturing Process:  
Extrusion Blow Molding

Overflow Capacity:  
130.0 - 142.0 ml (4.4 - 4.8 oz)

Gram Weight:  
13 ± 1

Neck Finish:  
24/410

Base Width (A):  
1.580 ± 0.050

Overall Height (B):  
5.377 ± 0.050

Max Print Area (Height):  
3.250"

Max Print Area (Width):  
4.750"

Case Pack: 480

Case Weight (lb): 15.9 ± 1.0

Cases Per Pallet: 25

Box Dimensions:  
23 5/8 x 15 9/16 x 17

Stock Material:



**CLASSIC CONTAINERS INC**  
1700 S. Hellman Ave.  
Ontario, CA 91761  
Phone: 909-930-3610  
e-mail: info@classiccontainers.com  
www.classiccontainers.com

### FRONT VIEW

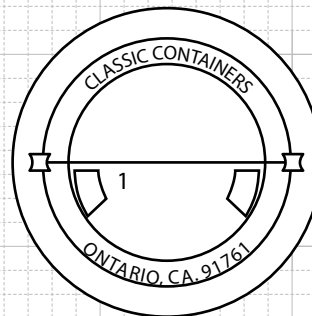
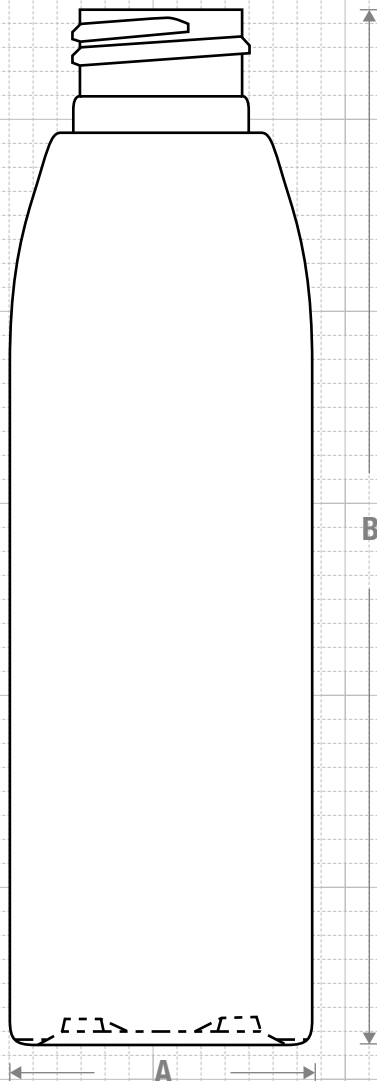

### BOTTOM VIEW

### NECK & THREAD DETAIL

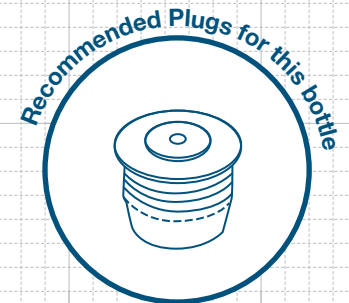
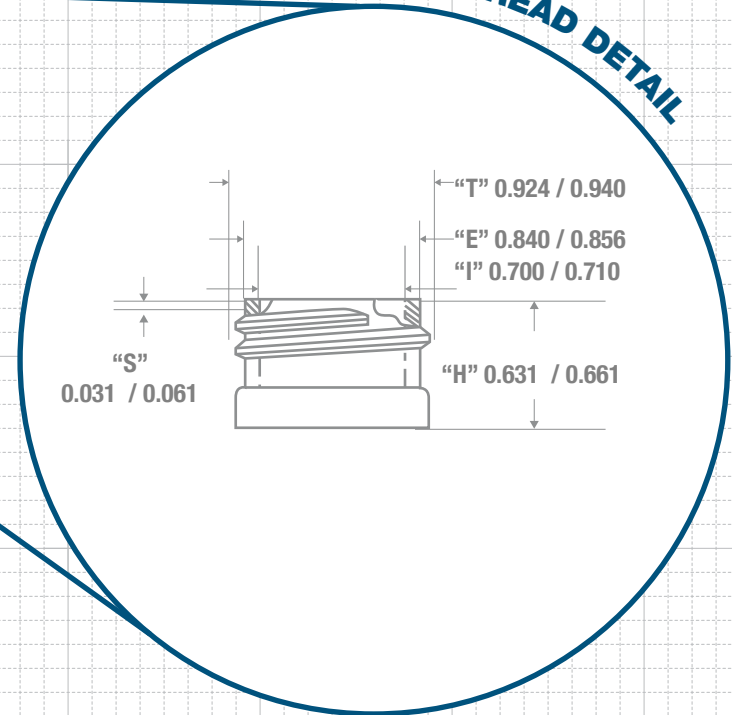
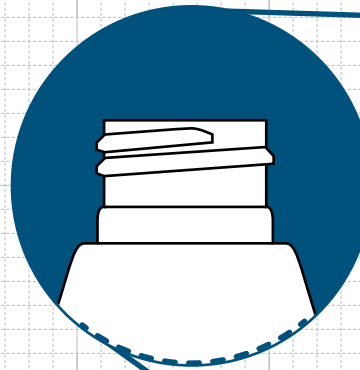

### FRICITION FIT



# PRINTING SPECIFICATIONS: 4 oz EVOLUTION 24/410

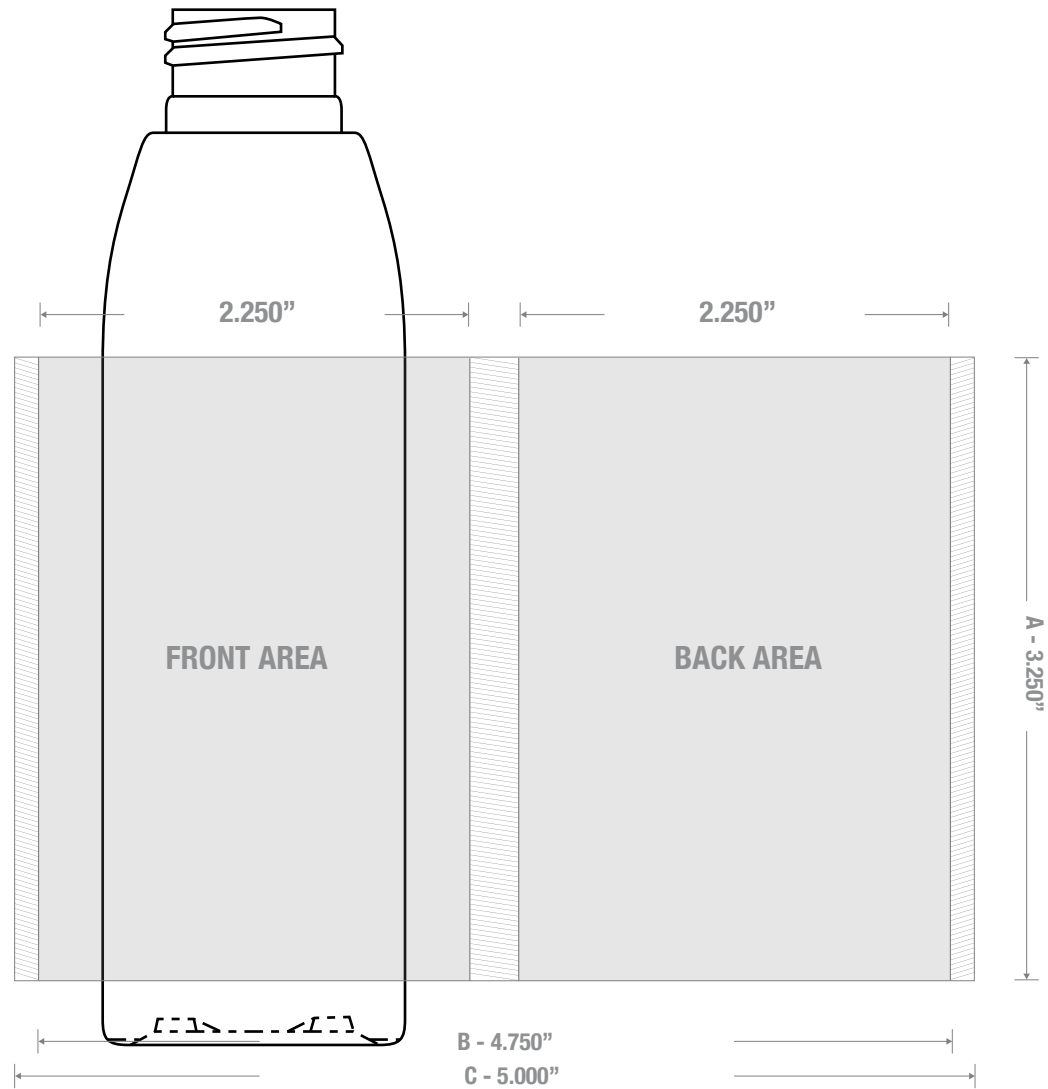

1700 S Hellman Ave, Ontario, California 91761  
Phone: (909) 930-3610 | Fax: (909) 930-3640  
e-mail: [info@classiccontainers.com](mailto:info@classiccontainers.com)  
[www.classiccontainers.com](http://www.classiccontainers.com)

**A - Total Height.**  
**B - Max. Decorating Area.**  
**C - Total bottle circumference.**  
▨ - Unprintable area.

# LABELING SPECIFICATIONS: 4 oz EVOLUTION 24/410

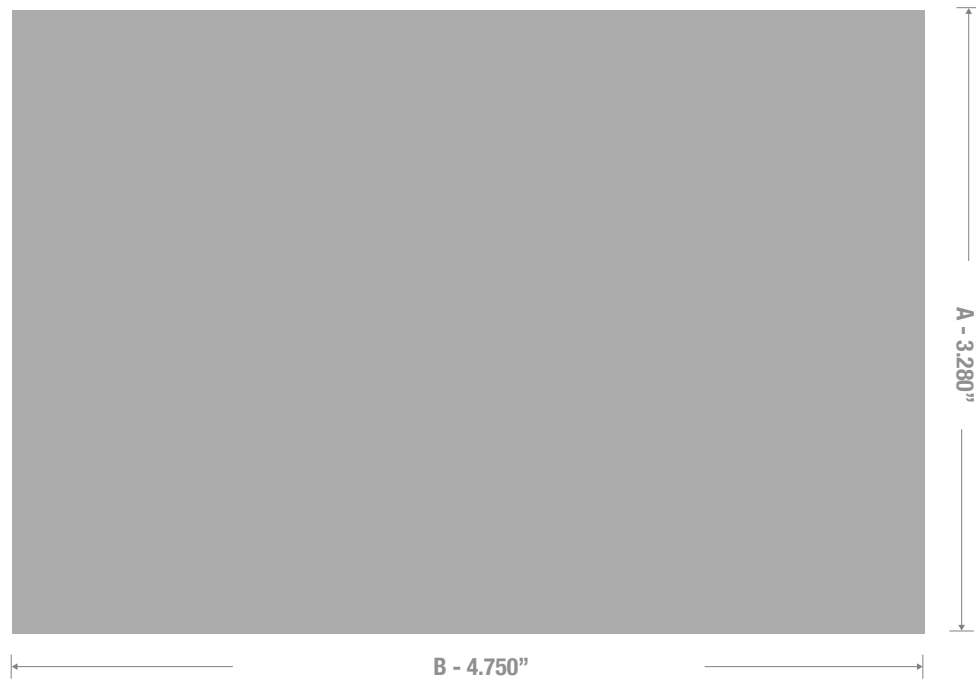

1700 S Hellman Ave, Ontario, California 91761  
Phone: (909) 930-3610 | Fax: (909) 930-3640  
e-mail: [info@classiccontainers.com](mailto:info@classiccontainers.com)  
[www.classiccontainers.com](http://www.classiccontainers.com)

**A - Total Height.**  
**B - Total bottle circumference.**