

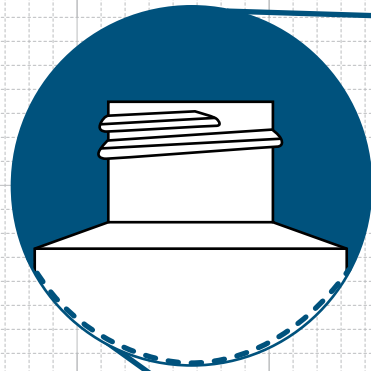

FRONT VIEW

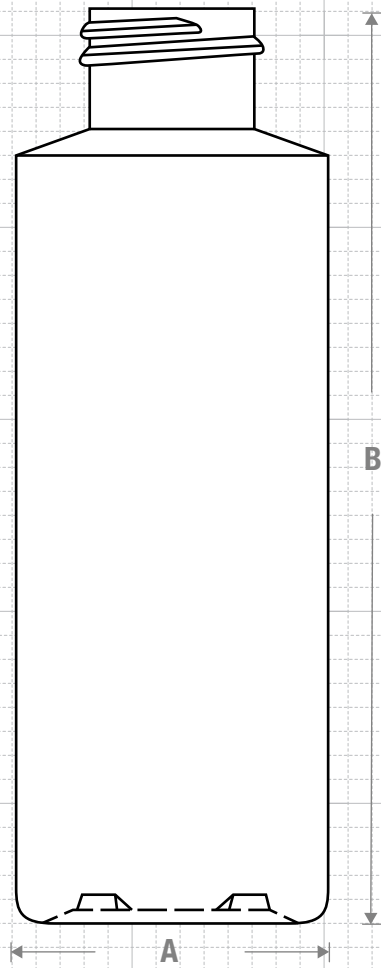

NECK & THREAD DETAIL

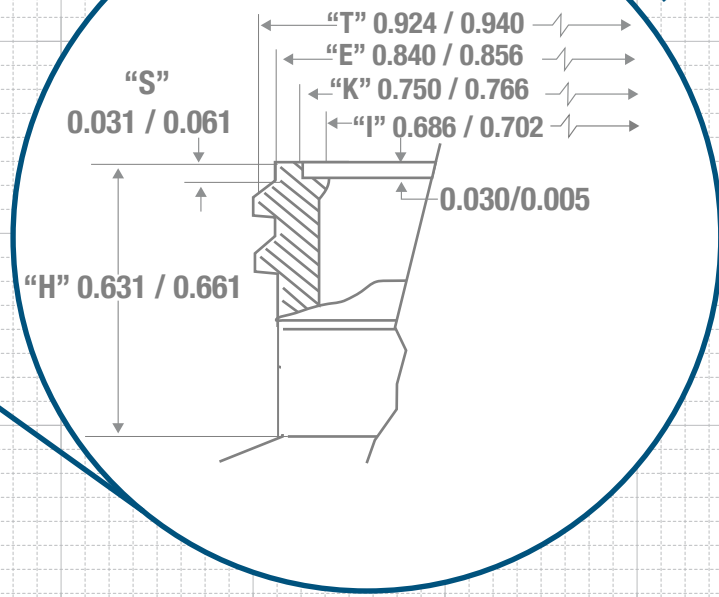

Drawing:
4 oz Cylinder Round 24/410

Stock Code:
000400010240000

Manufacturing Process:
Injection Blow Molding

Overflow Capacity:
124 - 133 ml (4.2 - 4.5 oz)

Gram Weight:
14 ± 1

Neck Finish:
24/410

Base Width (A):
1.625 ± 0.050

Overall Height (B):
4.765 ± 0.050

Max Print Area (Height):
3.480"

Max Print Area (Width):
4.875"

Case Pack: 489

Case Weight (lb): 18 ± 1.0

Cases Per Pallet: 25

Box Dimensions:
23 5/8 x 15 9/16 x 17

Stock Material:

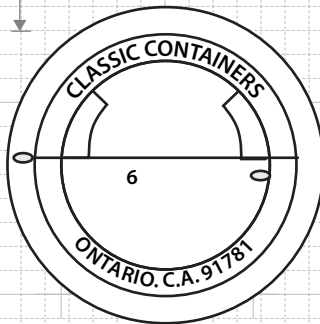

4 Cavity

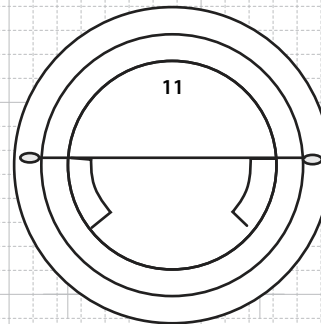

8 Cavity

BOTTOM VIEW

Recommended Plugs for this bottle



SNAP FIT

CLASSIC CONTAINERS INC
1700 S. Hellman Ave.
Ontario, CA 91761
Phone: 909-930-3610
e-mail: info@classiccontainers.com
www.classiccontainers.com

PRINTING SPECIFICATIONS: 4 oz CYLINDER ROUND 24/410

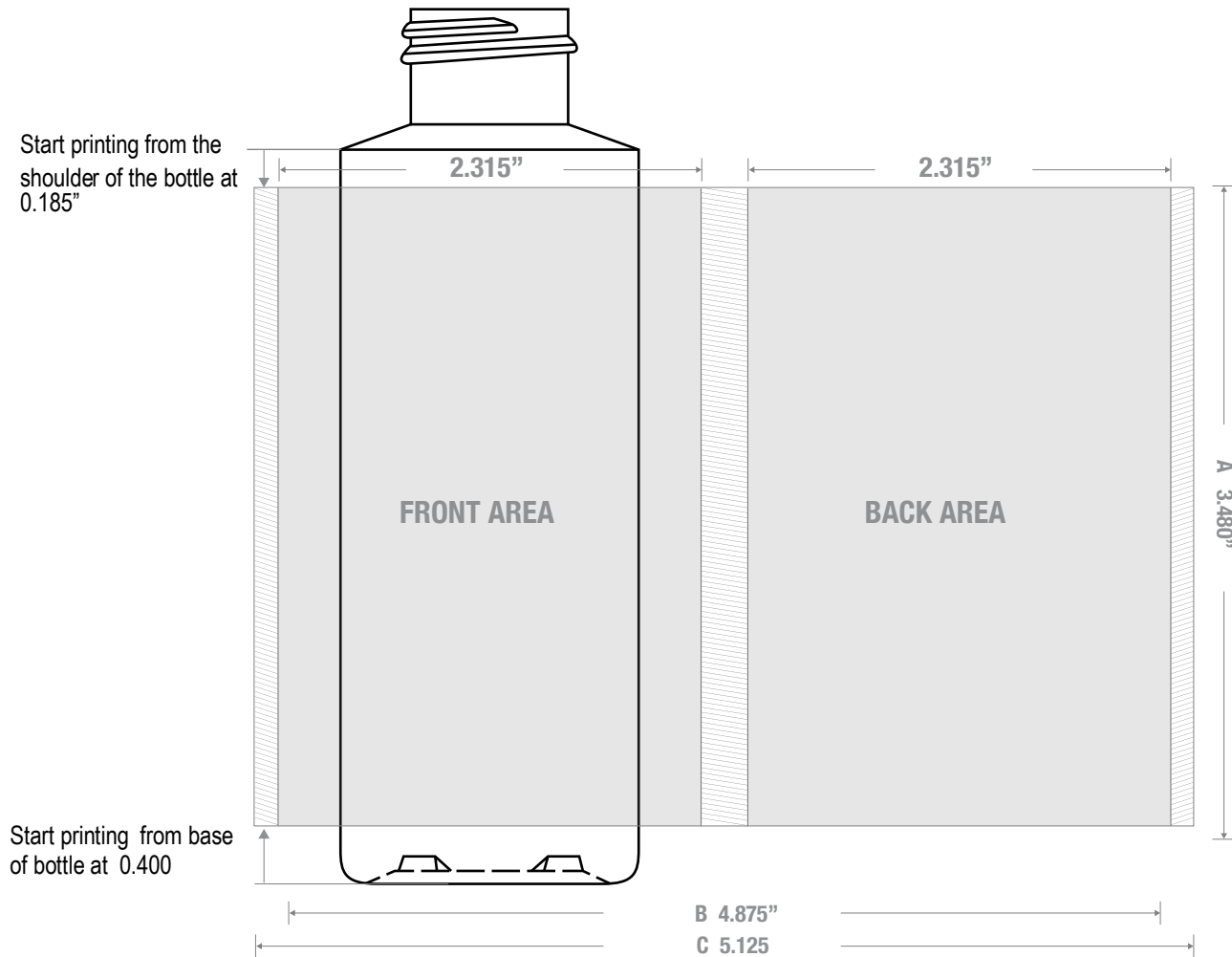

1700 S Hellman Ave, Ontario, California 91761
 Phone: (909) 930-3610 | Fax: (909) 930-3640
 e-mail: info@classiccontainers.com
www.classiccontainers.com

A - Total Height.
B - Max. Decorating Area.
C - Total bottle circumference.
 [Hatched Box] - Unprintable area.

LABELING SPECIFICATIONS: 4 oz CYLINDER ROUND 24/410



1700 S Hellman Ave, Ontario, California 91761
Phone: (909) 930-3610 | Fax: (909) 930-3640
e-mail: info@classiccontainers.com
www.classiccontainers.com

A - Total Height.
B - Total bottle circumference.