

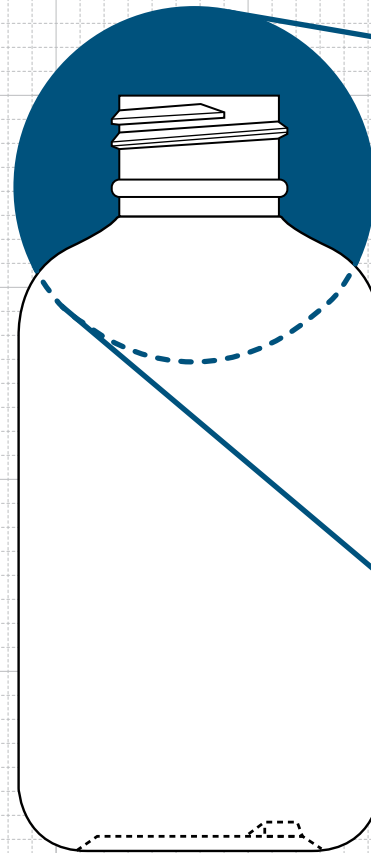

### FRONT VIEW

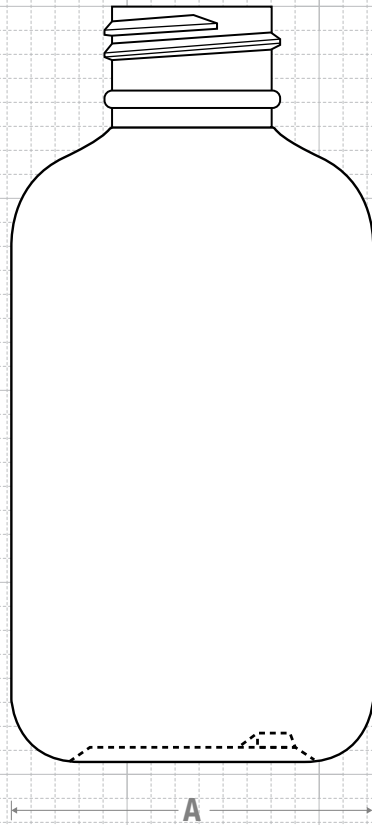

### NECK & THREAD DETAIL

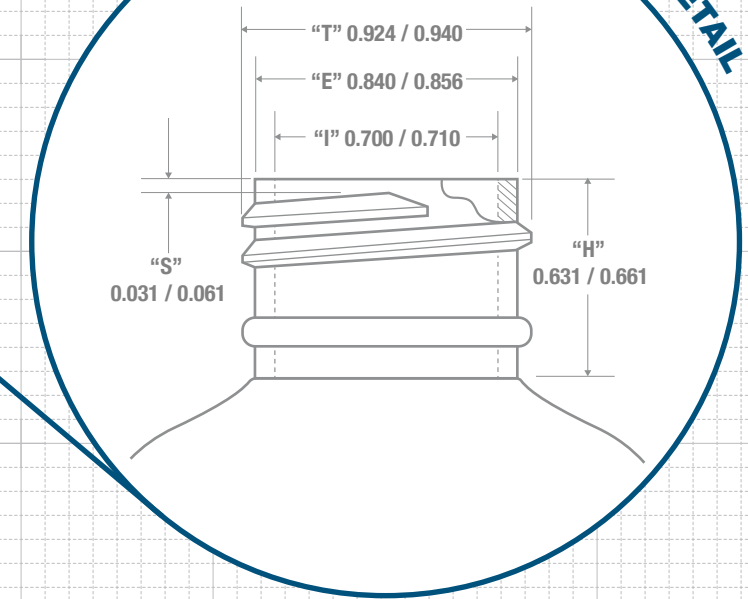

Drawing:  
4 oz Boston Round 24/410

Stock Code:  
000400060240000

Manufacturing Process:  
Extrusion Blow Molding

Overflow Capacity:  
130 - 142 ml (4.4 - 4.8 oz)

Gram Weight:  
13.5 ± 1

Neck Finish:  
24/410

Base Width (A):  
1.885 ± 0.050

Overall Height (B):  
3.934 ± 0.050

Max Print Area (Height):  
2.187"

Max Print Area (Width):  
5.687"

Case Pack: 480

Case Weight (lb): 16.4 ± 1.0

Cases Per Pallet: 25

Box Dimensions:  
23 5/8 x 15 9/16 x 17

Stock Material:



**CLASSIC CONTAINERS INC**  
1700 S. Hellman Ave.  
Ontario, CA 91761  
Phone: 909-930-3610  
e-mail: info@classiccontainers.com  
www.classiccontainers.com



#### Other Material Options

Stock Material: **LD/PE**,  
Case Pack: **432**  
Case Weight (lb): **15.0 ± 1.0**

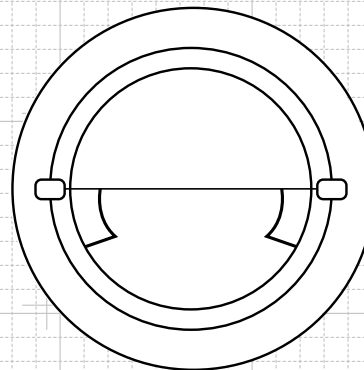

### BOTTOM VIEW

Recommended Plugs for this bottle



### FRICITION FIT

# PRINTING SPECIFICATIONS: 4 oz BOSTON ROUND

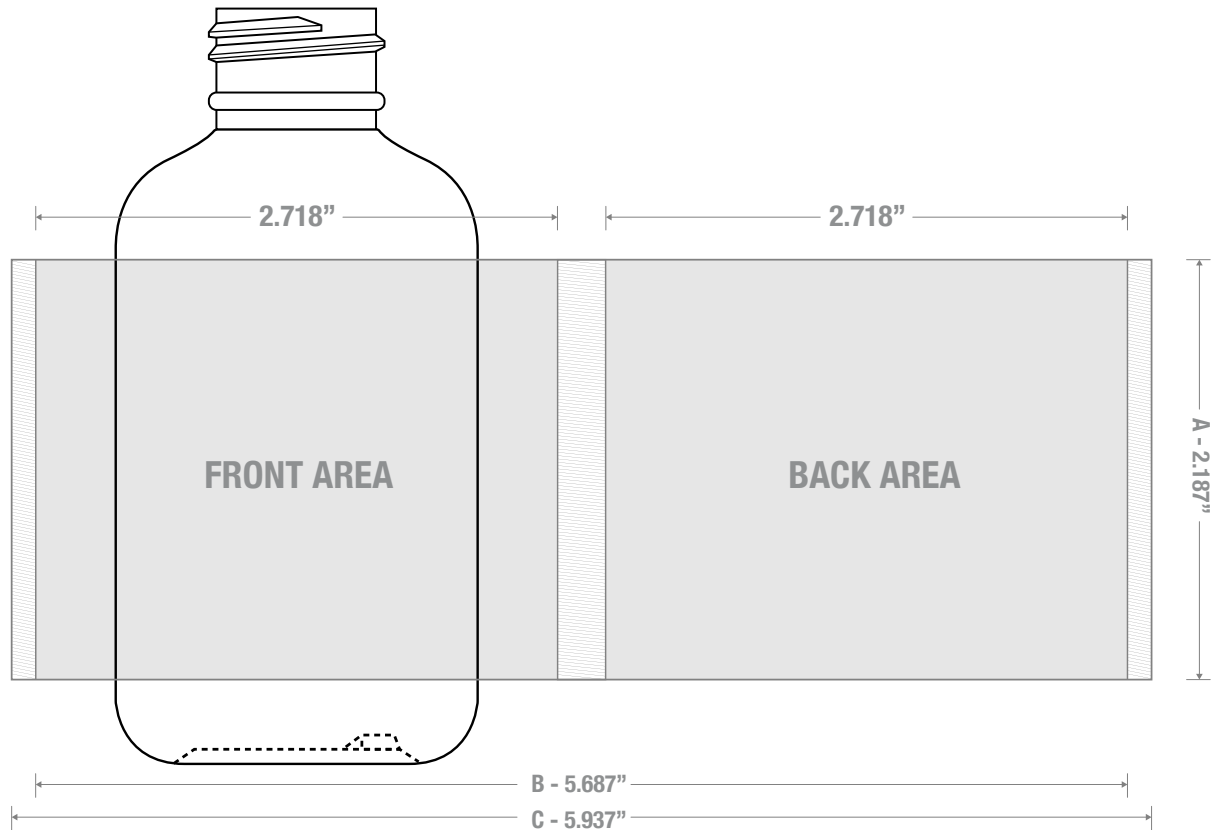

1700 S Hellman Ave, Ontario, California 91761  
Phone: (909) 930-3610 | Fax: (909) 930-3640  
e-mail: [info@classiccontainers.com](mailto:info@classiccontainers.com)  
[www.classiccontainers.com](http://www.classiccontainers.com)

**A - Total Height.**  
**B - Max. Decorating Area.**  
**C - Total bottle circumference.**  
☐ - Unprintable area.

# LABELING SPECIFICATIONS: 4 oz BOSTON ROUND



1700 S Hellman Ave, Ontario, California 91761  
Phone: (909) 930-3610 | Fax: (909) 930-3640  
e-mail: [info@classiccontainers.com](mailto:info@classiccontainers.com)  
[www.classiccontainers.com](http://www.classiccontainers.com)

**A - Total Height.**  
**B - Max. Decorating Area.**