



# FRONT VIEW



Drawing:  
4 oz Boston Round 20/415

Stock Code:  
000400060210000

Manufacturing Process:  
Extrusion Blow Molding

Overflow Capacity:  
124 - 136 ml (4.2 - 4.6 oz)

Gram Weight:  
13.5 ± 1

Neck Finish:  
20/415

Base Width (A):  
1.885 ± 0.050

Overall Height (B):  
4.105 ± 0.050

Max Print Area (Height):  
2.187"

Max Print Area (Width):  
5.687"

Case Pack: 432

Case Weight (lb): 15.0 ± 1.0

Cases Per Pallet: 25

Box Dimensions:  
23 5/8 x 15 9/16 x 17

Stock Material:

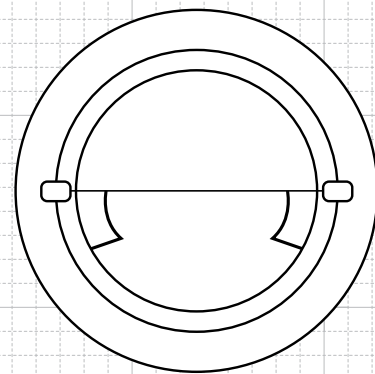
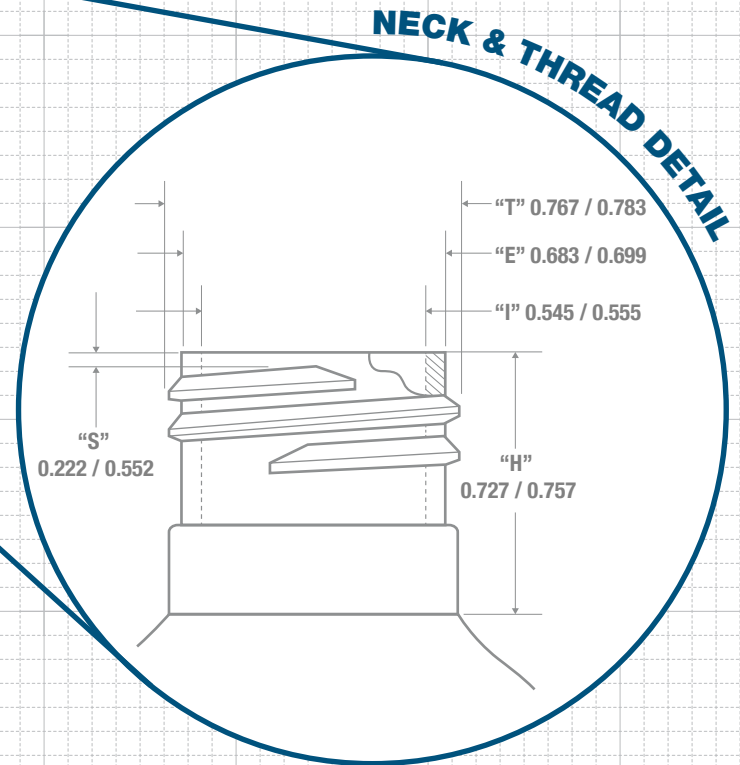
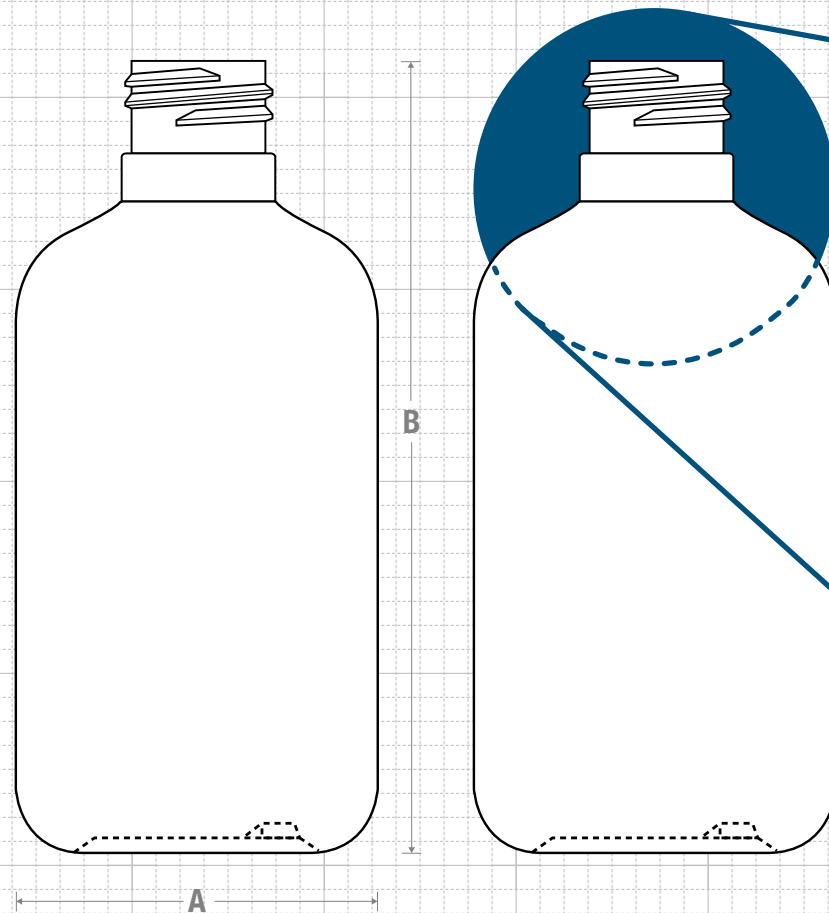

# BOTTOM VIEW

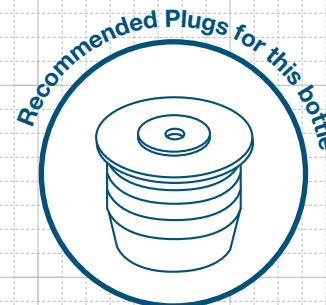

FRICION FIT

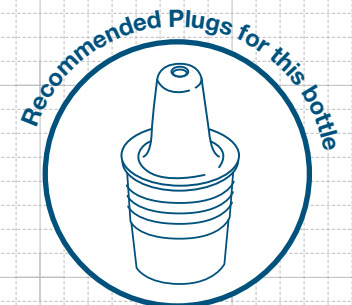

FRICION FIT

CLASSIC CONTAINERS INC  
1700 S. Hellman Ave.  
Ontario, CA 91761  
Phone: 909-930-3610  
e-mail: info@classiccontainers.com  
www.classiccontainers.com

# PRINTING SPECIFICATIONS: 4 oz BOSTON ROUND

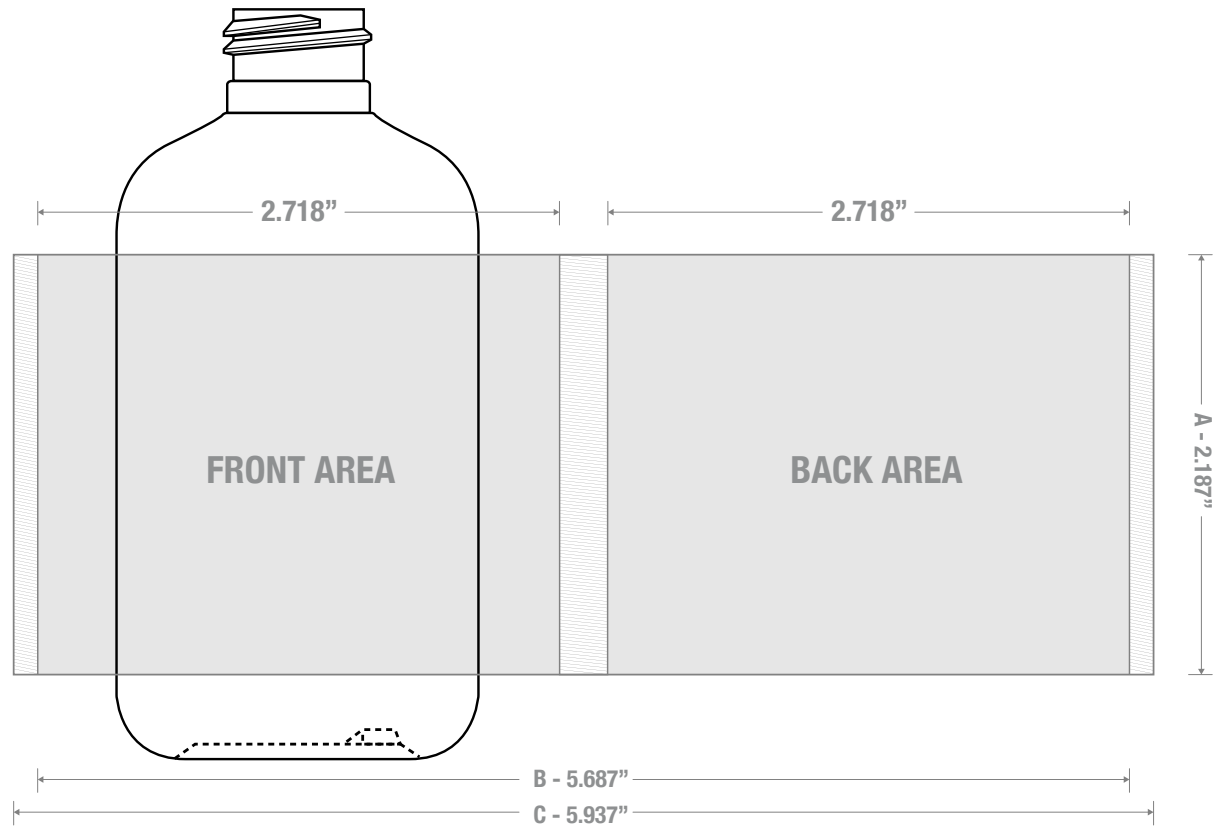

**LASSIC  
CONTAINERS  
Inc.**

1700 S Hellman Ave, Ontario, California 91761  
Phone: (909) 930-3610 | Fax: (909) 930-3640  
e-mail: [info@classiccontainers.com](mailto:info@classiccontainers.com)  
[www.classiccontainers.com](http://www.classiccontainers.com)

**A - Total Height.**  
**B - Max. Decorating Area.**  
**C - Total bottle circumference.**  
▨ - Unprintable area.

# LABELING SPECIFICATIONS: 4 oz BOSTON ROUND



1700 S Hellman Ave, Ontario, California 91761  
Phone: (909) 930-3610 | Fax: (909) 930-3640  
e-mail: [info@classiccontainers.com](mailto:info@classiccontainers.com)  
[www.classiccontainers.com](http://www.classiccontainers.com)

**A - Total Height.**  
**B - Max. Decorating Area.**