



# FRONT VIEW

Drawing:  
3 oz Cylinder Round 33/430

Stock Code:  
000300010320000

Manufacturing Process:  
Extrusion Blow Molding

Overflow Capacity:  
100 - 109 ml (3.4 - 3.7 oz)

Gram Weight:  
15 - 16

Neck Finish:  
33/430

Base Width (A):  
1.405 ± 0.050

Overall Height (B):  
5.000 ± 0.050

Max Print Area (Height):  
3.625"

Max Print Area (Width):  
4.189"

Case Pack: 600

Case Weight (lb): 22.6 ± 0.7

Cases Per Pallet: 25

Box Dimensions:  
23 5/8 x 15 9/16 x 17

Stock Material:



**CLASSIC CONTAINERS INC**  
1700 S. Hellman Ave.  
Ontario, CA 91761  
Phone: 909-930-3610  
e-mail: info@classiccontainers.com  
www.classiccontainers.com

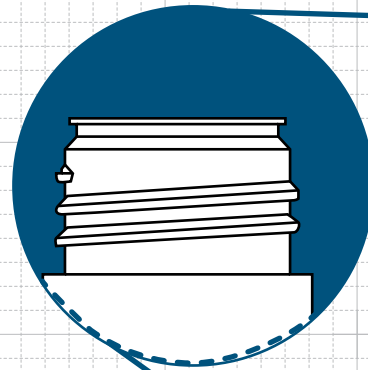
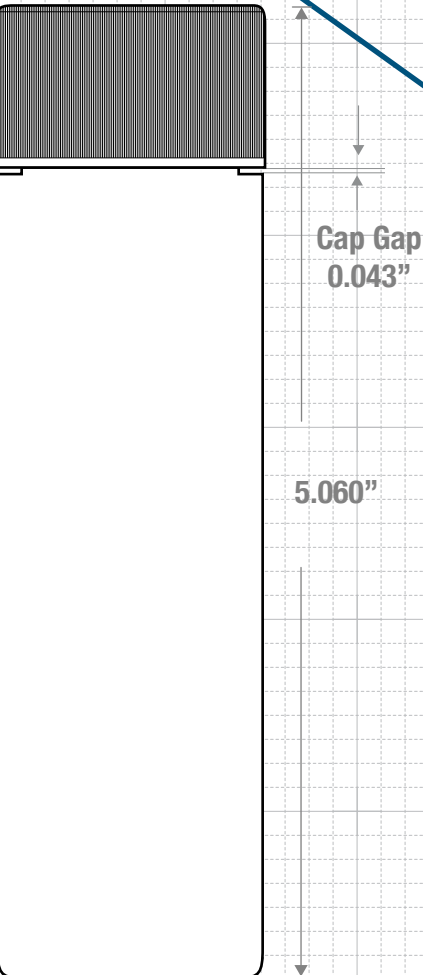
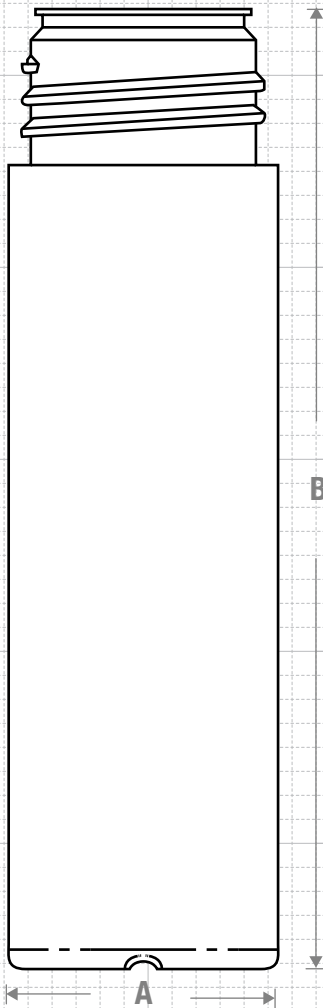

# NECK & THREAD DETAIL

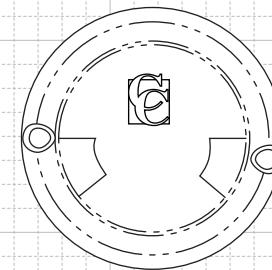
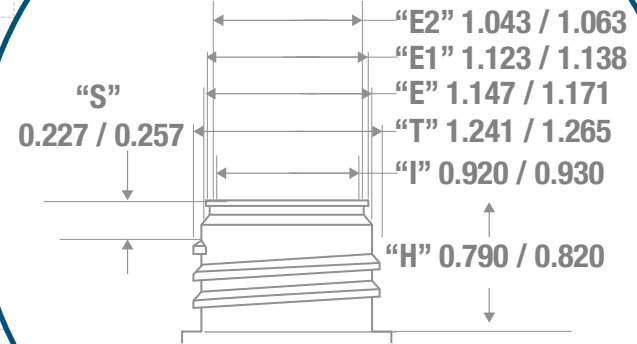

# BOTTOM VIEW



# PRINTING SPECIFICATIONS: 3 oz CYLINDER ROUND 33/430

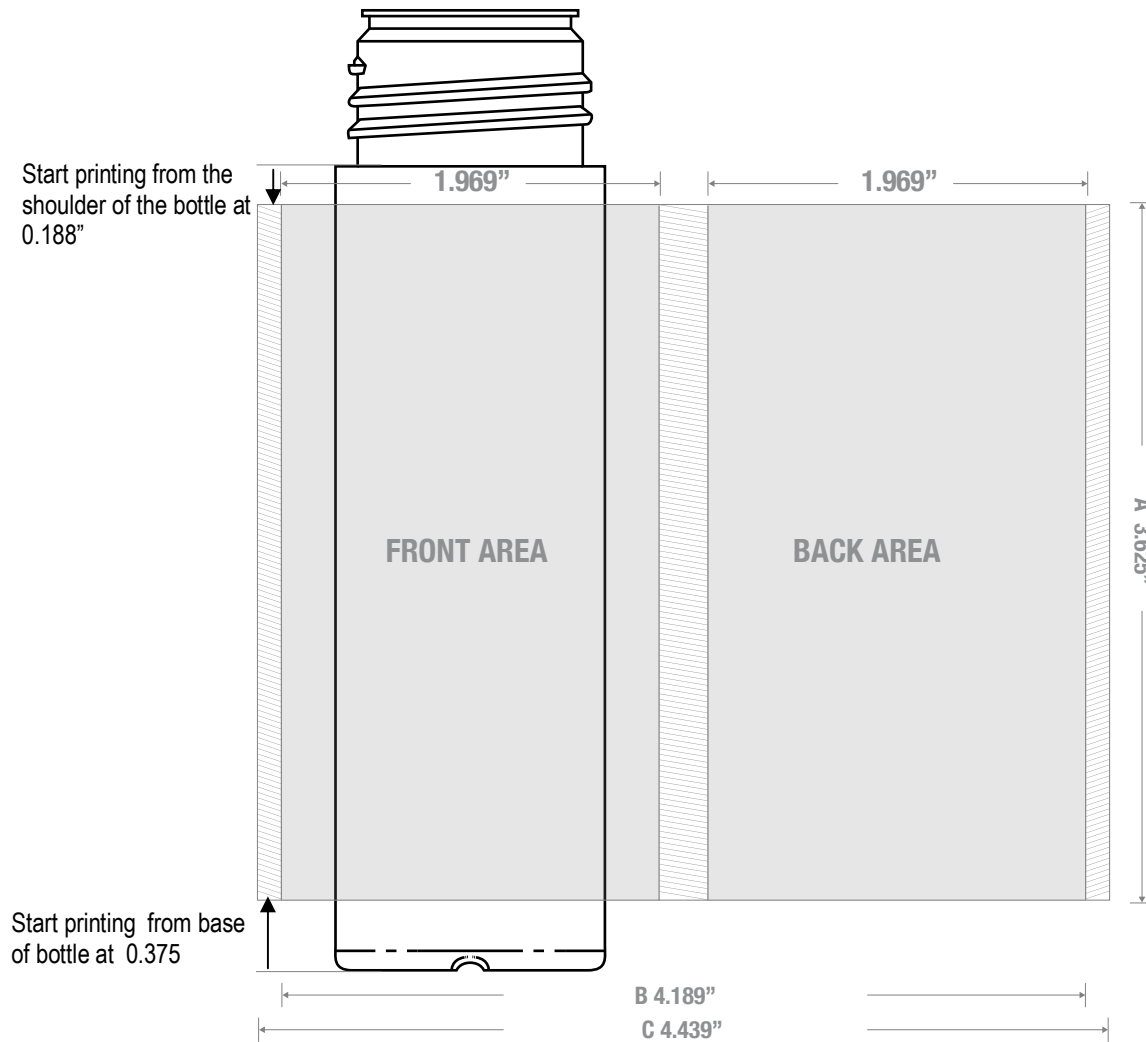

1700 S Hellman Ave, Ontario, California 91761  
 Phone: (909) 930-3610 | Fax: (909) 930-3640  
 e-mail: [info@classiccontainers.com](mailto:info@classiccontainers.com)  
[www.classiccontainers.com](http://www.classiccontainers.com)

**A - Total Height.**  
**B - Max. Decorating Area.**  
**C - Total bottle circumference.**  
 [Hatched Box] - Unprintable area.

# LABELING SPECIFICATIONS: 3 oz CYLINDER ROUND 33/430



1700 S Hellman Ave, Ontario, California 91761  
Phone: (909) 930-3610 | Fax: (909) 930-3640  
e-mail: [info@classiccontainers.com](mailto:info@classiccontainers.com)  
[www.classiccontainers.com](http://www.classiccontainers.com)

**A - Total Height.**  
**B - Total bottle circumference.**