



HDPE



LDPE



PP



OTHER

NECK & THREAD DETAIL

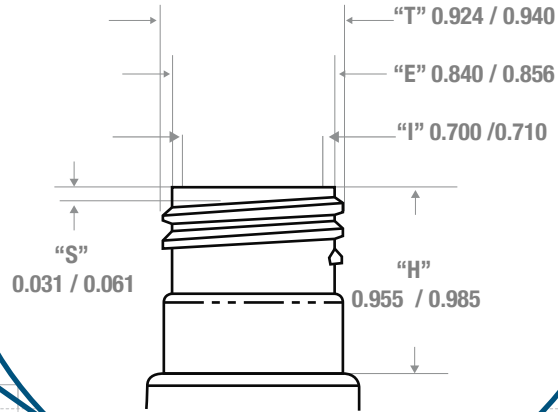

FRONT VIEW

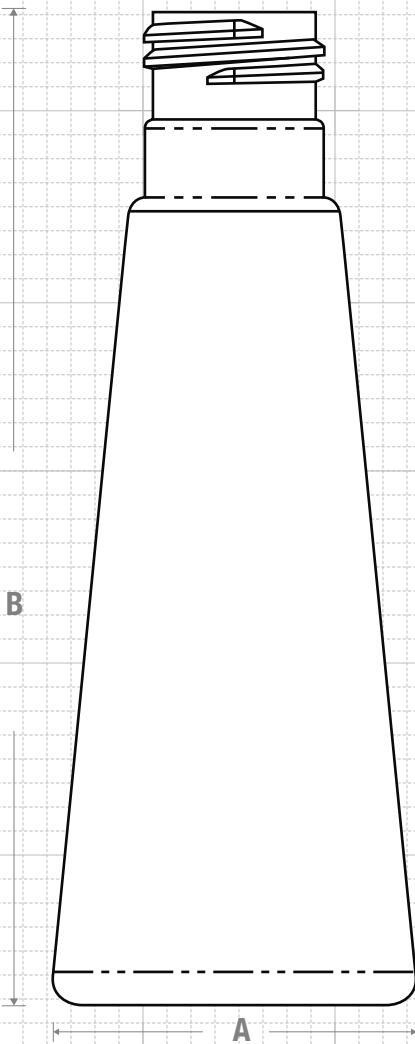

SIDE VIEW

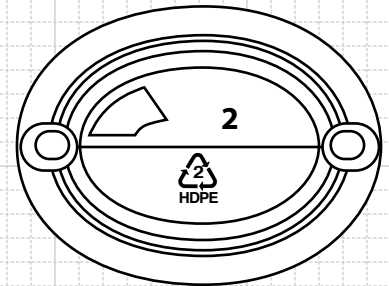
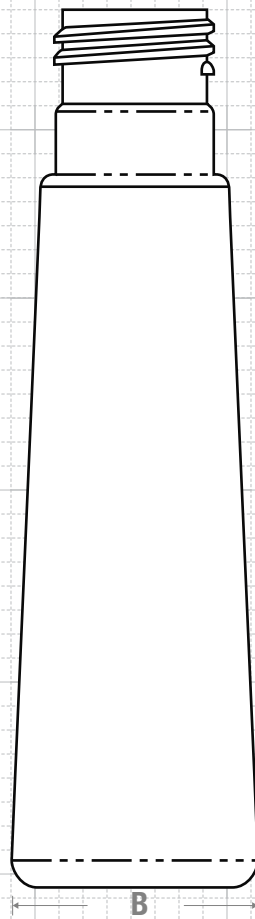

BOTTOM VIEW



CLASSIC CONTAINERS INC
 1700 S. Hellman Ave.
 Ontario, CA 91761
 Phone: 909-930-3610
 e-mail: info@classiccontainers.com
 www.classiccontainers.com

Drawing: 3 oz Tri Oval	Gram Weight: 10.5 ± 1 g	Max Print Area (Height): 3.400"	Cases Per Pallet: 25
Stock Code: 000300590250000	Neck Finish: 24/415	Max Print Area (Width): (A) 0.850" (B) 1.350	Box Dimensions: 23 5/8 x 15 9/16 x 17
Manufacturing Process: Extrusion Blow Molding	Base Width (A): Base Width (B): 1.884 ± 0.050 1.445 ± 0.050	Case Pack: 609	Stock Material:
Overflow Capacity: 88.72 - 99.95 ml (3.3 - 3.6 oz)	Overall Height (B): 5.170 ± 0.050	Case Weight (lb): 16.2 ± 1.3	Rev #0- 08/04/2017 Drawing not exactly to size.

LABELING SPECIFICATIONS: 3 oz Tri 24/415

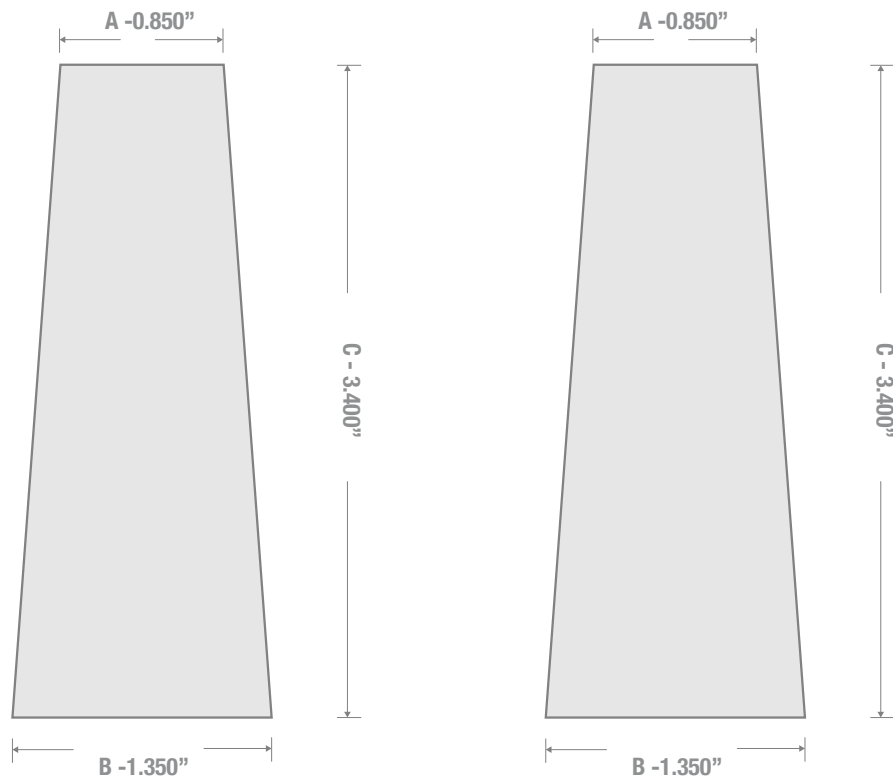

1700 S Hellman Ave, Ontario, California 91761
Phone: (909) 930-3610 | Fax: (909) 930-3640
e-mail: info@classiccontainers.com
www.classiccontainers.com

A - Total Height.
B - Max. Decorating Area.