

FRONT VIEW

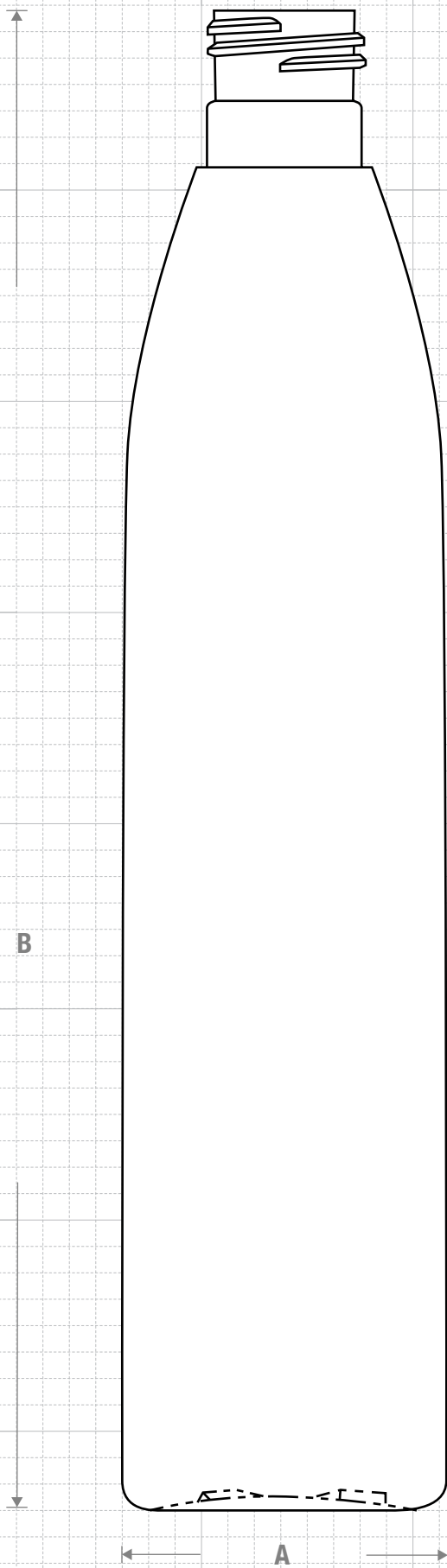

NECK & THREAD DETAIL

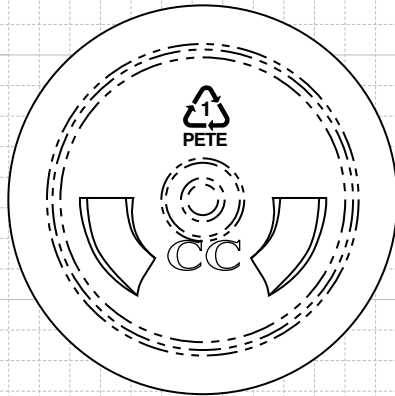
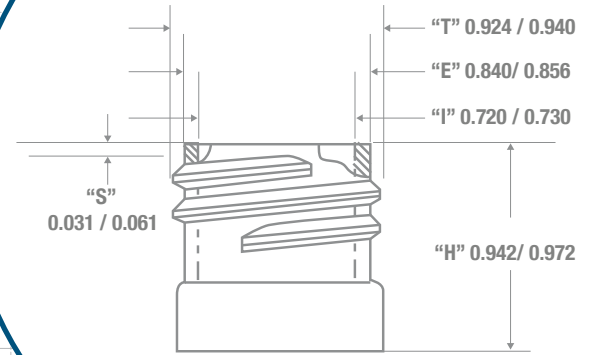

BOTTOM VIEW

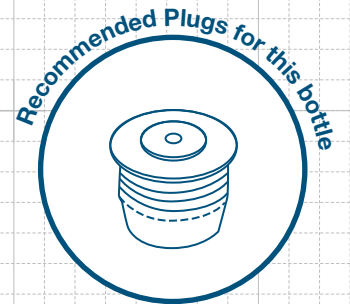

FRICION FIT

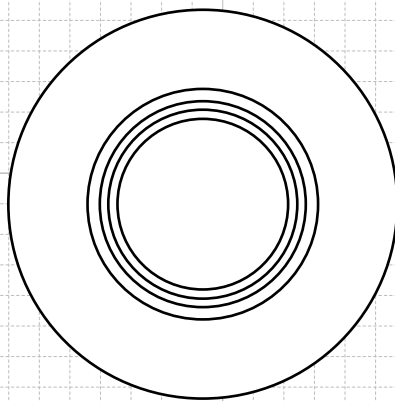

TOP VIEW



CLASSIC CONTAINERS INC
 1700 S. Hellman Ave.
 Ontario, CA 91761
 Phone: 909-930-3610
 e-mail: info@classiccontainers.com
 www.classiccontainers.com

Drawing: 350 ml Evolution Slim 24/415	Gram Weight: 31 ± 1	Max Print Area (Height): 5.250"	Cases Per Pallet: 16
Stock Code: 0350000470250000	Neck Finish: 24/415	Max Print Area (Width): 6.187"	Box Dimensions: 24 7/16 x 18 1/2 x 23
Manufacturing Process: Strech Blow Molding	Base Width (A): 2.025 ± 0.050	Case Pack: 278	Stock Material:
Overflow Capacity: 357 - 375 ml(12.1 - 12.7 oz)	Overall Height (B): 9.107 ± 0.050	Case Weight (lb): 21.9 ± 0.6	Rev #2 03/2016 Drawing not exactly to size.