



Drawing:  
**350 ml Boston Round 24/415**

Stock Code:  
**035000060251700**

Manufacturing Process:  
**Stretch Blow Molding**

Overflow Capacity:  
**372 - 389 ml (12.6 - 13.2 oz)**

Gram Weight:  
**31 ± 1**

Neck Finish:  
**24/415**

Base Width (A):  
**2.635 ± 0.050**

Overall Height (B):  
**5.670 ± 0.050**

Max Print Area (Height):  
**3.313"**

Max Print Area (Width):  
**8.125"**

Case Pack: **272**

Case Weight (lb): **21.5 ± 0.6**

Cases Per Pallet: **16**

Box Dimensions:  
**24 7/16 x 18 1/2 x 23**

Stock Material:



**CLASSIC CONTAINERS INC**  
1700 S. Hellman Ave.  
Ontario, CA 91761  
Phone: 909-930-3610  
e-mail: info@classiccontainers.com  
[www.classiccontainers.com](http://www.classiccontainers.com)

**FRONT VIEW**

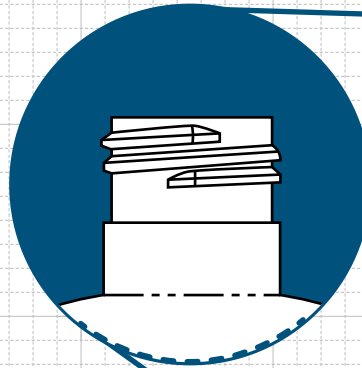
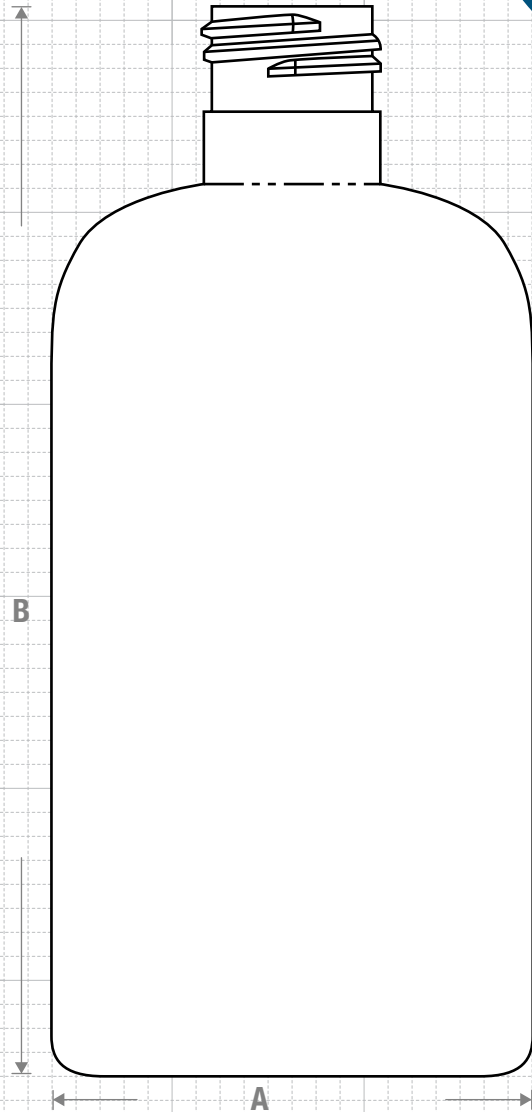

**NECK & THREAD DETAIL**

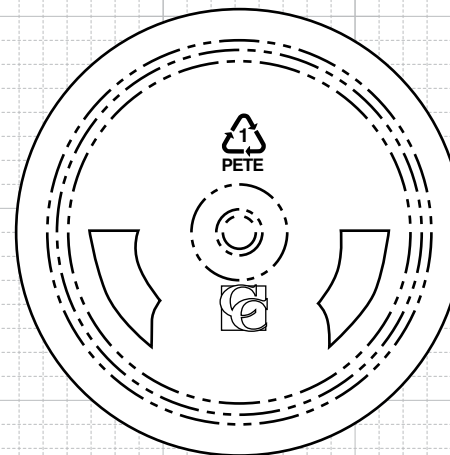
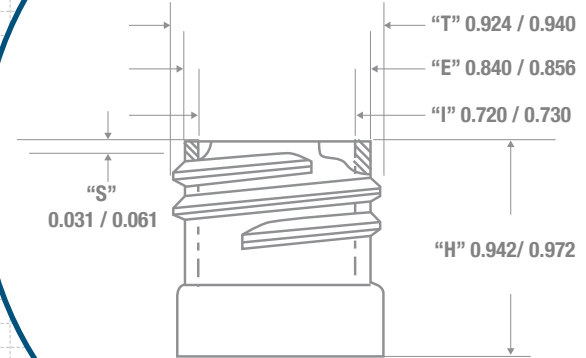

**BOTTOM VIEW**

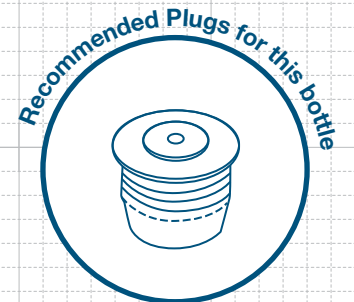

**FRICITION FIT**

PRINTING SPECIFICATIONS: 350 ml BOSTON ROUND 24/415

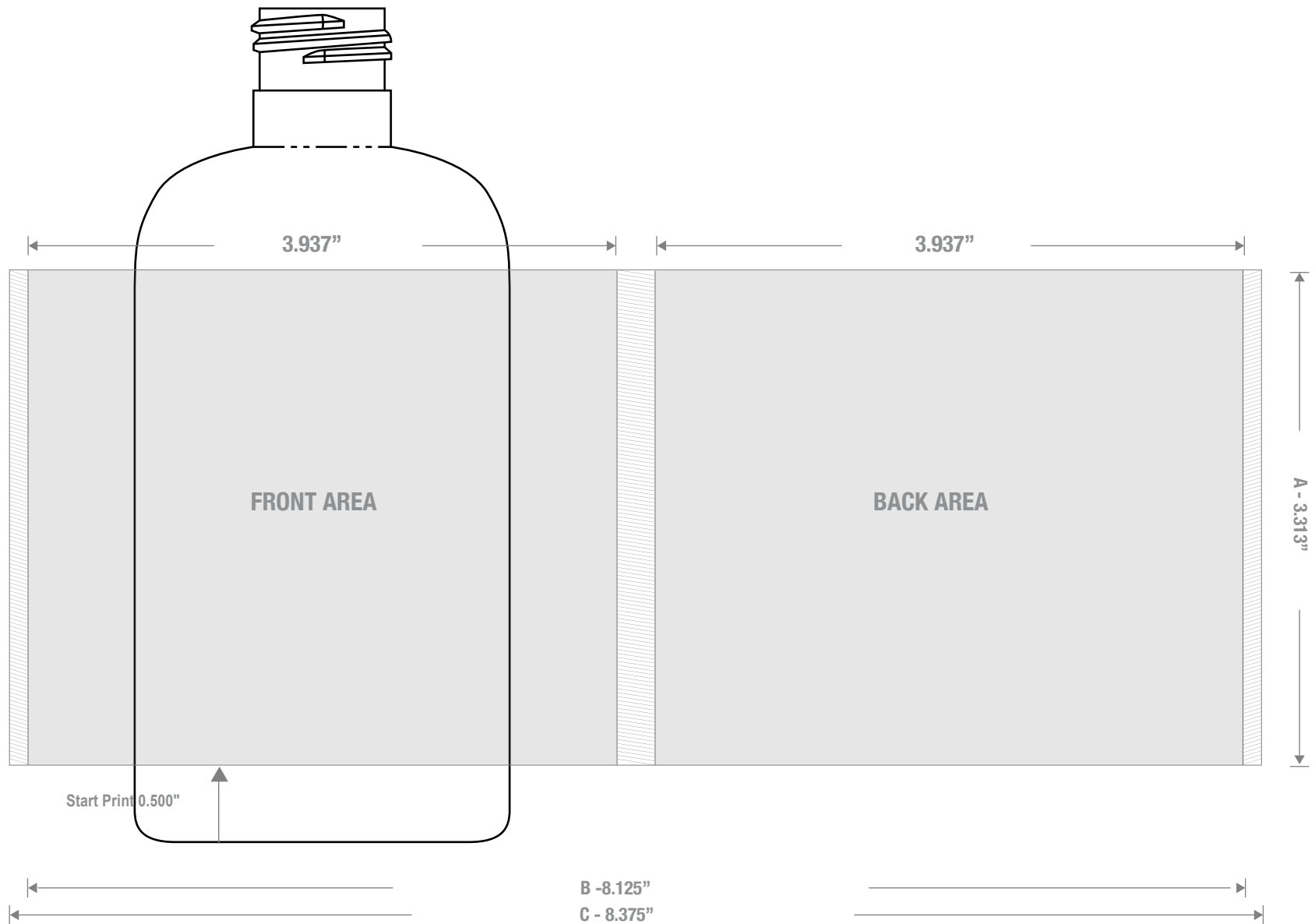

1700 S Hellman Ave, Ontario, California 91761  
 Phone: (909) 930-3610 | Fax: (909) 930-3640  
 e-mail: [info@classiccontainers.com](mailto:info@classiccontainers.com)  
[www.classiccontainers.com](http://www.classiccontainers.com)

**A - Total Height.**  
**B - Max. Decorating Area.**  
**C - Total bottle circumference.**  
 [Hatched Box] - Unprintable area.

# LABELING SPECIFICATIONS: 350 ml BOSTON ROUND 24/415



1700 S Hellman Ave, Ontario, California 91761  
Phone: (909) 930-3610 | Fax: (909) 930-3640  
e-mail: [info@classiccontainers.com](mailto:info@classiccontainers.com)  
[www.classiccontainers.com](http://www.classiccontainers.com)

**A - Total Height.**  
**B - Max. Decorating Area.**