



Drawing:
350 ml Boston Round 24/410

Stock Code:
035000060241700

Manufacturing Process:
Stretch Blow Molding

Overflow Capacity:
369 - 386 ml (12.5 - 13.1 oz)

Gram Weight:
31 ± 1

Neck Finish:
24/410

Base Width (A):
2.635 ± 0.050

Overall Height (B):
5.370 ± 0.050

Max Print Area (Height):
3.313"

Max Print Area (Width):
8.125"

Case Pack: 272

Case Weight (lb): 21.5 ± 0.6

Cases Per Pallet: 16

Box Dimensions:
24 7/16 x 18 1/2 x 23

Stock Material:



CLASSIC CONTAINERS INC
1700 S. Hellman Ave.
Ontario, CA 91761
Phone: 909-930-3610
e-mail: info@classiccontainers.com
www.classiccontainers.com

FRONT VIEW

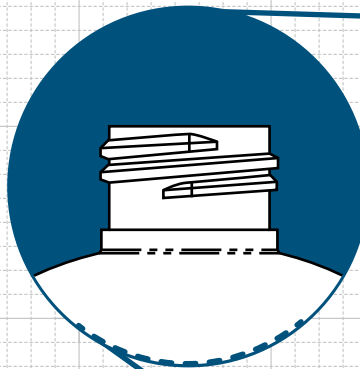
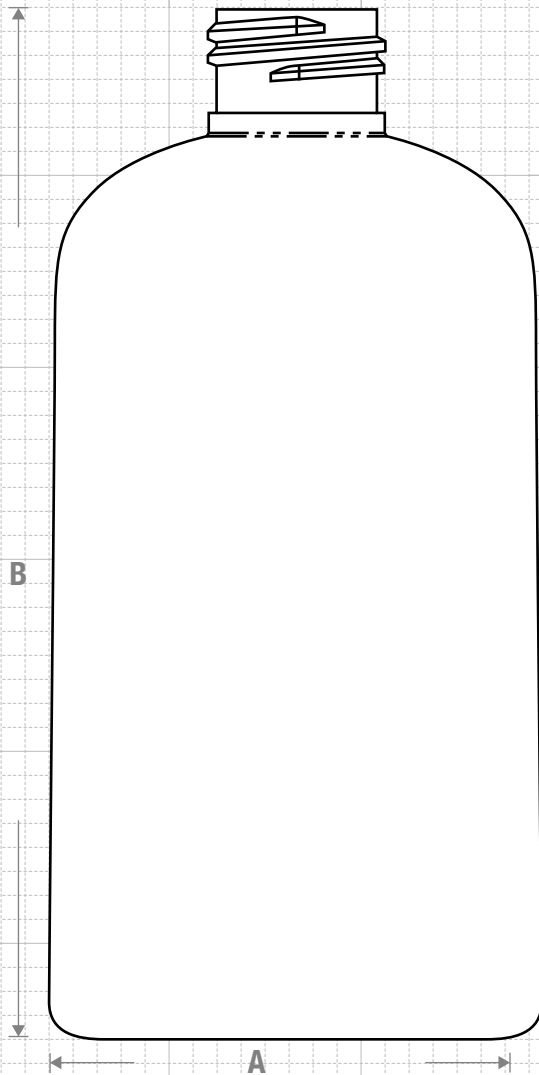

NECK & THREAD DETAIL

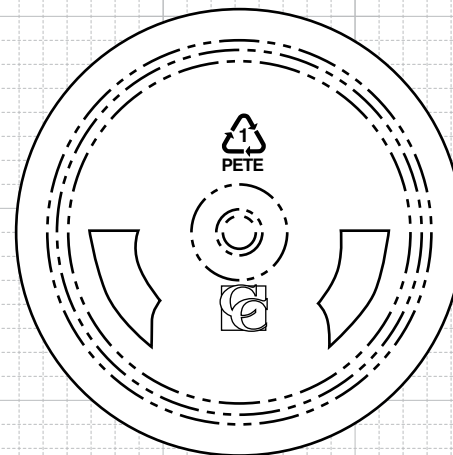
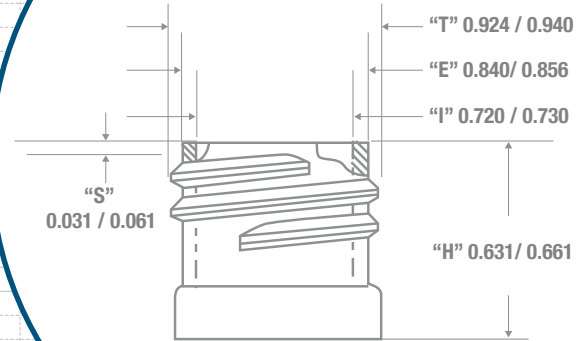

BOTTOM VIEW

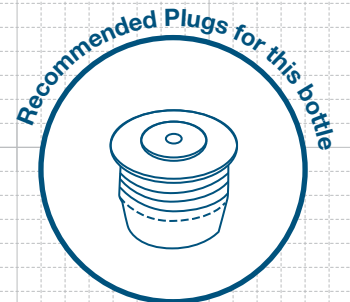

FRICION FIT

PRINTING SPECIFICATIONS: 350 ml BOSTON ROUND 24/410

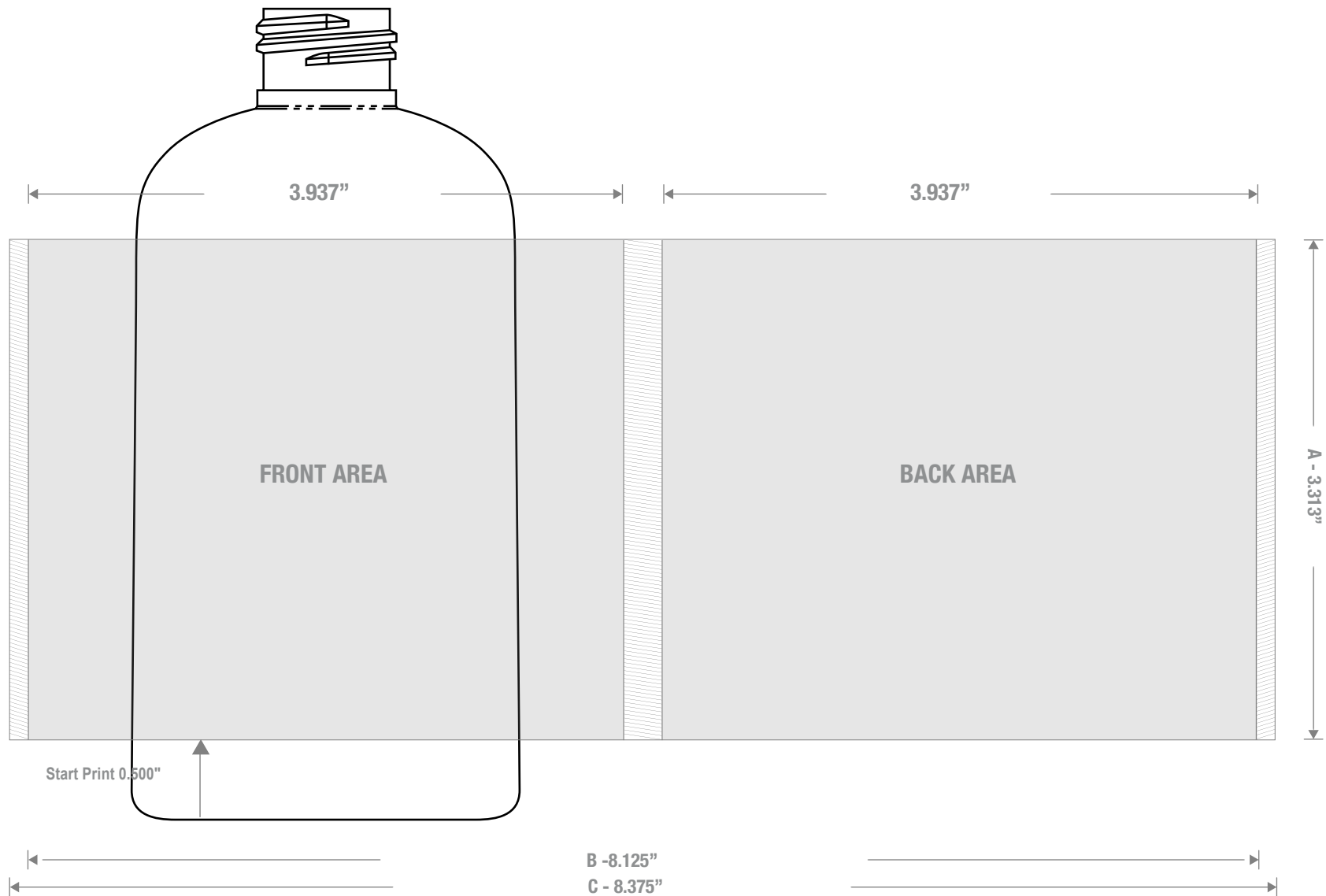

1700 S Hellman Ave, Ontario, California 91761
 Phone: (909) 930-3610 | Fax: (909) 930-3640
 e-mail: info@classiccontainers.com
www.classiccontainers.com

A - Total Height.
B - Max. Decorating Area.
C - Total bottle circumference.
 [Hatched Box] - Unprintable area.

LABELING SPECIFICATIONS: 350 ml BOSTON ROUND 24/410



1700 S Hellman Ave, Ontario, California 91761
Phone: (909) 930-3610 | Fax: (909) 930-3640
e-mail: info@classiccontainers.com
www.classiccontainers.com

A - Total Height.
B - Max. Decorating Area.