

**FRONT VIEW**

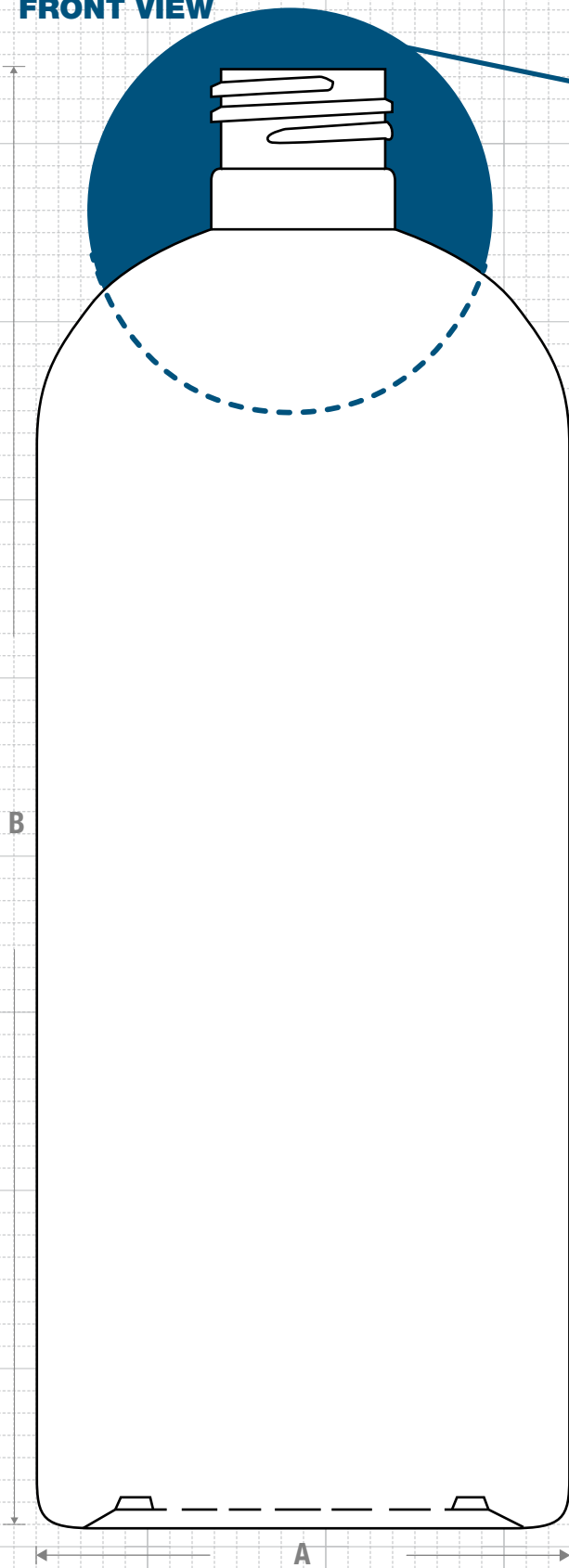

**NECK & THREAD DETAIL**

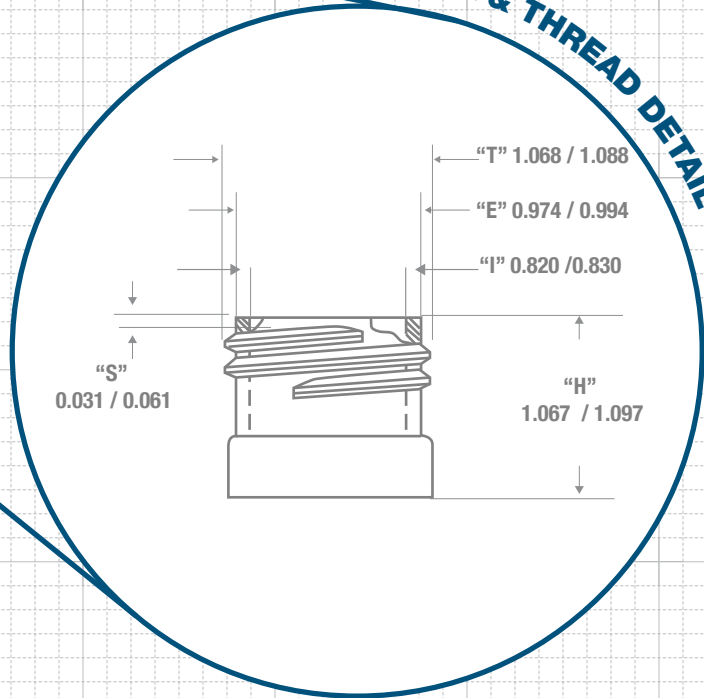

**BOTTOM VIEW**

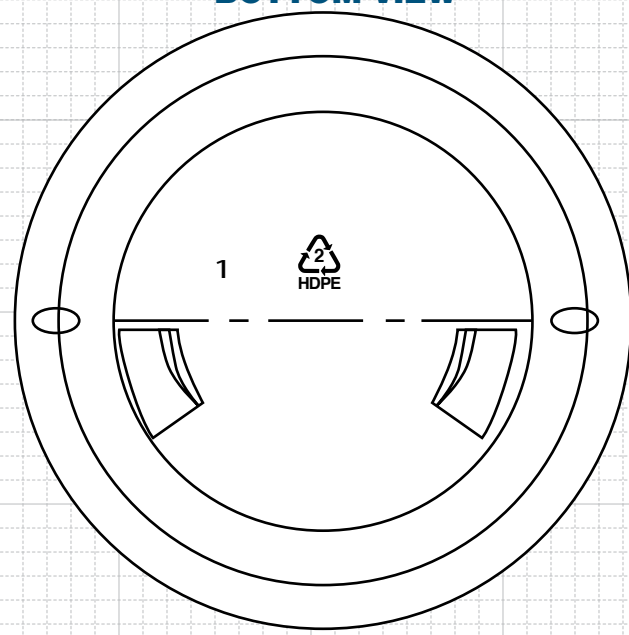

**CLASSIC CONTAINERS INC**  
 1700 S. Hellman Ave.  
 Ontario, CA 91761  
 Phone: 909-930-3610  
 e-mail: info@classiccontainers.com  
 www.classiccontainers.com

Drawing: <b>32 oz Imperial Round 28/415</b>	Gram Weight: <b>58 ± 2 grs</b>	Max Print Area (Height): <b>6.688"</b>	Cases Per Pallet: <b>16</b>
Stock Code: <b>003200050290000</b>	Neck Finish: <b>28/415</b>	Max Print Area (Width): <b>9.875"</b>	Box Dimensions: <b>24 7/16 x 18 1/2 x 23</b>
Manufacturing Process: <b>Extrusion Blow Molding</b>	Base Width (A): <b>3.210 ± 0.05</b>	Case Pack: <b>98</b>	Stock Material:
Overflow Capacity: <b>1027 - 1050 ml (34.8 - 35.6 oz)</b>	Overall Height (B): <b>9.750 ± 0.050</b>	Case Weight (lb): <b>15.4 ± 0.4</b>	Rev #4 08/2018 Drawing not exactly to size.

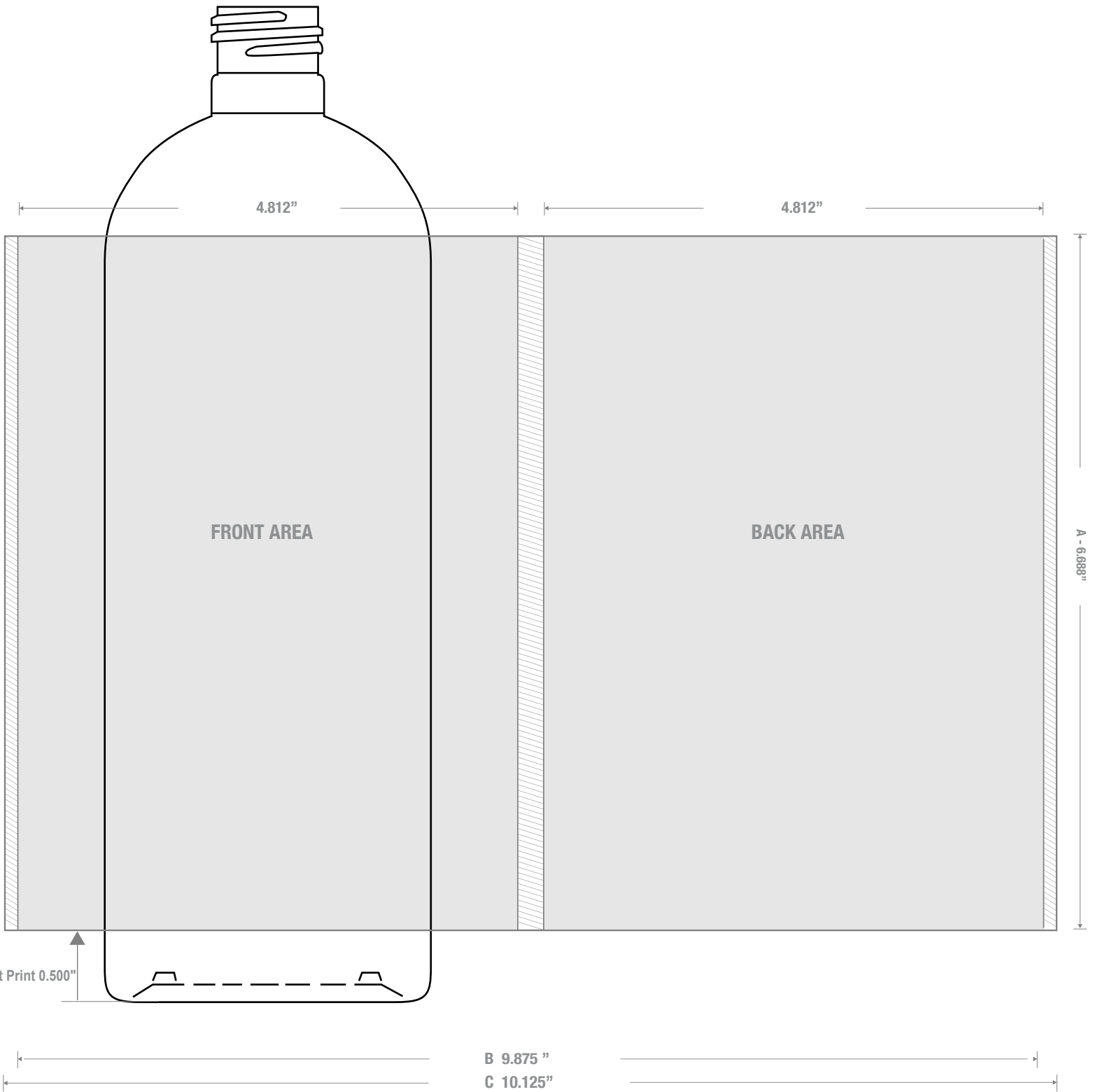

1700 S Hellman Ave, Ontario, California 91761  
Phone: (909) 930-3610 | Fax: (909) 930-3640  
e-mail: [info@classiccontainers.com](mailto:info@classiccontainers.com)  
[www.classiccontainers.com](http://www.classiccontainers.com)

**A - Total Height.**  
**B - Max. Decorating Area.**  
**C - Total bottle circumference.**  
☐ Unprintable area

LABELING SPECIFICATIONS (WRAP LABEL): 32oz IMPERIAL ROUND 28/415



1700 S Hillman Ave, Ontario, California 91761  
Phone: (909) 930-3610 | Fax: (909) 930-3640  
e-mail: [info@classiccontainers.com](mailto:info@classiccontainers.com)  
[www.classiccontainers.com](http://www.classiccontainers.com)

**A - Total Height.**  
**B - Total bottle circumference.**