

FRONT VIEW

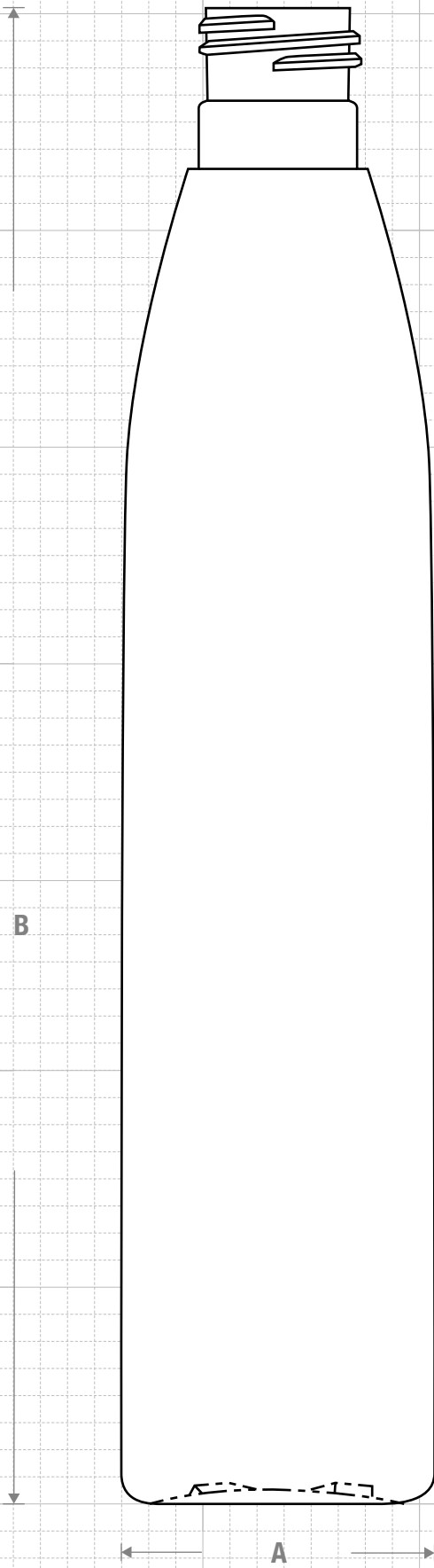

NECK & THREAD DETAIL

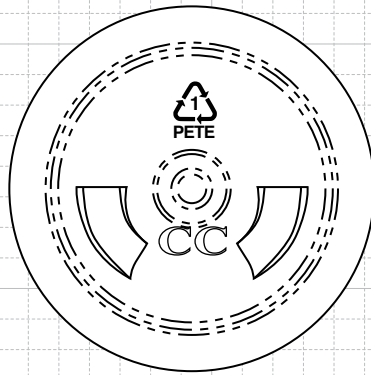
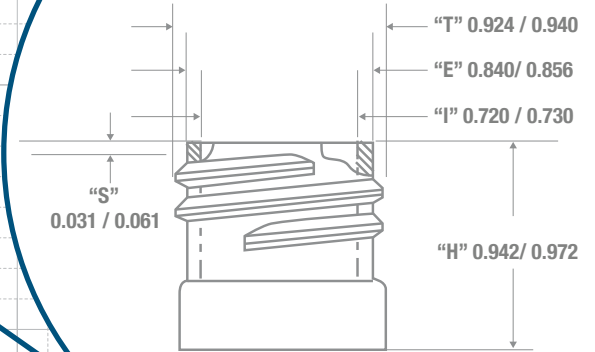

BOTTOM VIEW

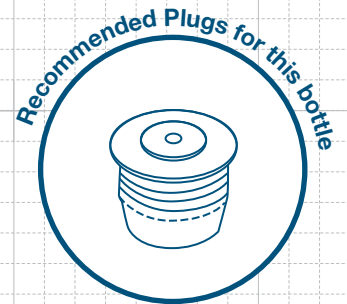

FRICTION FIT

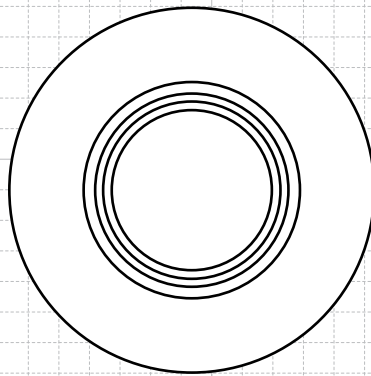

TOP VIEW



CLASSIC CONTAINERS INC
 1700 S. Hellman Ave.
 Ontario, CA 91761
 Phone: 909-930-3610
 e-mail: info@classiccontainers.com
 www.classiccontainers.com

Drawing: 300 ml Evolution Slim 24/415	Gram Weight: 25 ± 1	Max Print Area (Height): 4.890"	Cases Per Pallet: 16
Stock Code: 030000470250000	Neck Finish: 24/415	Max Print Area (Width): 5.738"	Box Dimensions: 24 7/16 x 18 1/2 x 23
Manufacturing Process: Stretch Blow Molding	Base Width (A): 1.900 ± 0.050	Case Pack: 312	Stock Material: 
Overflow Capacity: 307- 325 ml (10.4 - 11.0 oz)	Overall Height (B): 8.807 ± 0.050	Case Weight (lb): 20.1 ± 0.7	Rev #2 03/2015 Drawing not exactly to size.