



Drawing:  
300 ml Boston Round 24/410

Stock Code:  
030000060241700

Manufacturing Process:  
Stretch Blow Molding

Overflow Capacity:  
313 - 330 ml (10.6 - 11.2 oz)

Gram Weight:  
25 ± 1

Neck Finish:  
24/410

Base Width (A):  
2.465 ± 0.050

Overall Height (B):  
5.160 ± 0.050

Max Print Area (Height):  
3.250"

Max Print Area (Width):  
7.574"

Case Pack: 308

Case Weight (lb): 19.9 ± 0.7

Cases Per Pallet: 16

Box Dimensions:  
24 7/16 x 18 1/2 x 23

Stock Material:



**CLASSIC CONTAINERS INC**  
1700 S. Hellman Ave.  
Ontario, CA 91761  
Phone: 909-930-3610  
e-mail: info@classiccontainers.com  
www.classiccontainers.com



### NECK & THREAD DETAIL

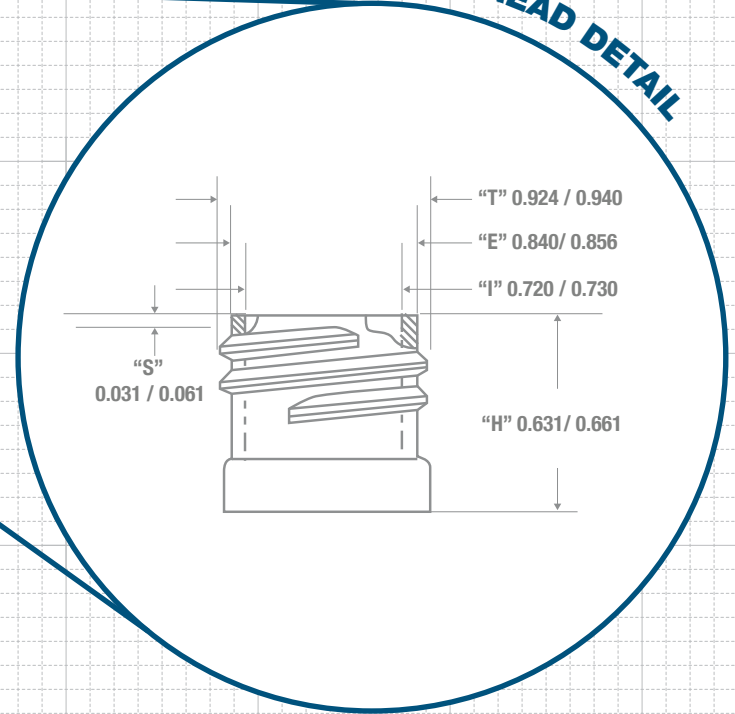
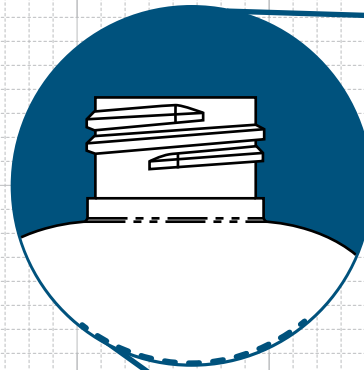

### FRONT VIEW

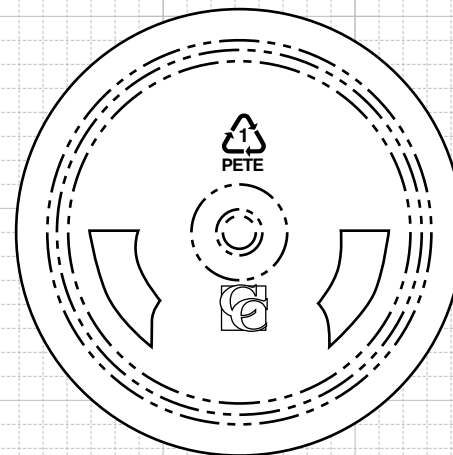
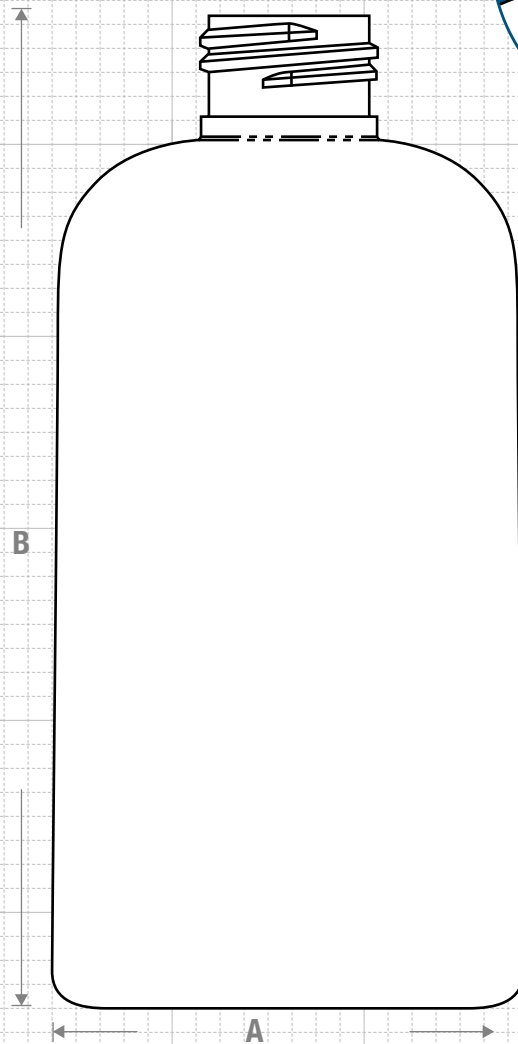

### BOTTOM VIEW

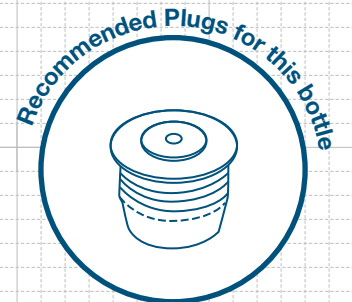

### FRICION FIT

PRINTING SPECIFICATIONS: 300 ml BOSTON ROUND 24/410

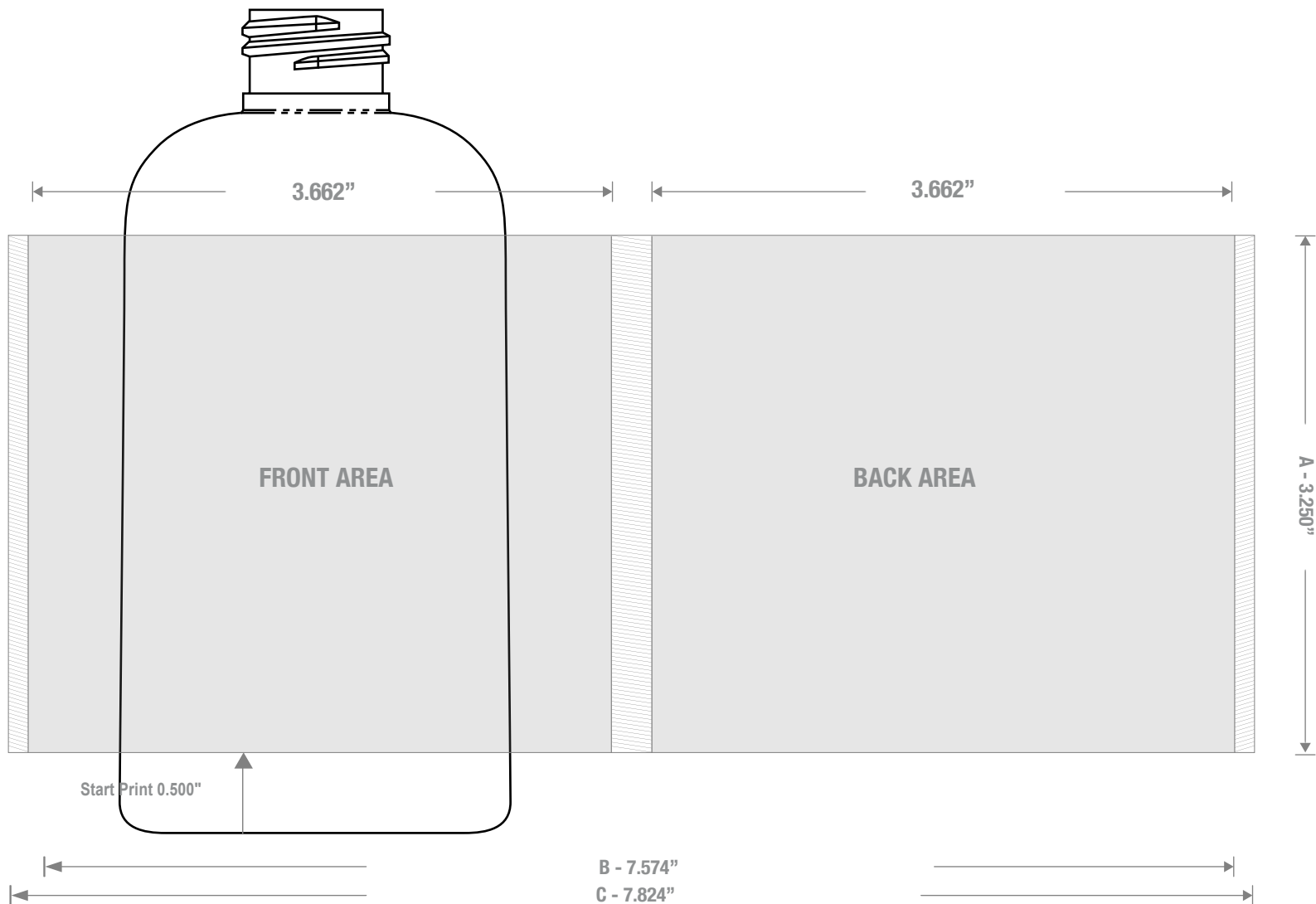

1700 S Hellman Ave, Ontario, California 91761  
 Phone: (909) 930-3610 | Fax: (909) 930-3640  
 e-mail: info@classiccontainers.com  
[www.classiccontainers.com](http://www.classiccontainers.com)

**A - Total Height.**  
**B - Max. Decorating Area.**  
**C - Total bottle circumference.**  
 [Hatched Box] - Unprintable area.

# LABELING SPECIFICATIONS: 300 ml BOSTON ROUND 24/410



1700 S Hellman Ave, Ontario, California 91761  
Phone: (909) 930-3610 | Fax: (909) 930-3640  
e-mail: [info@classiccontainers.com](mailto:info@classiccontainers.com)  
[www.classiccontainers.com](http://www.classiccontainers.com)

**A - Total Height.**  
**B - Max. Decorating Area.**