

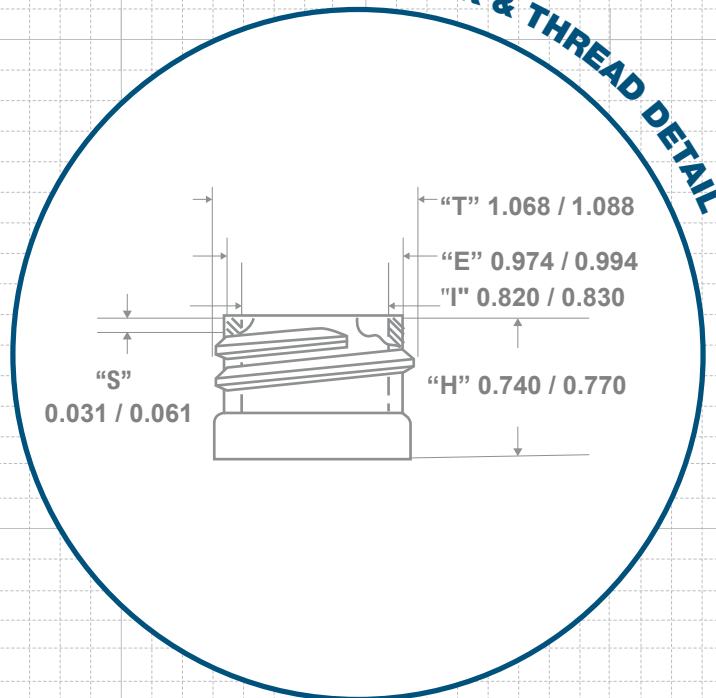

NECK & THREAD DETAIL



FRONT VIEW

SIDE VIEW

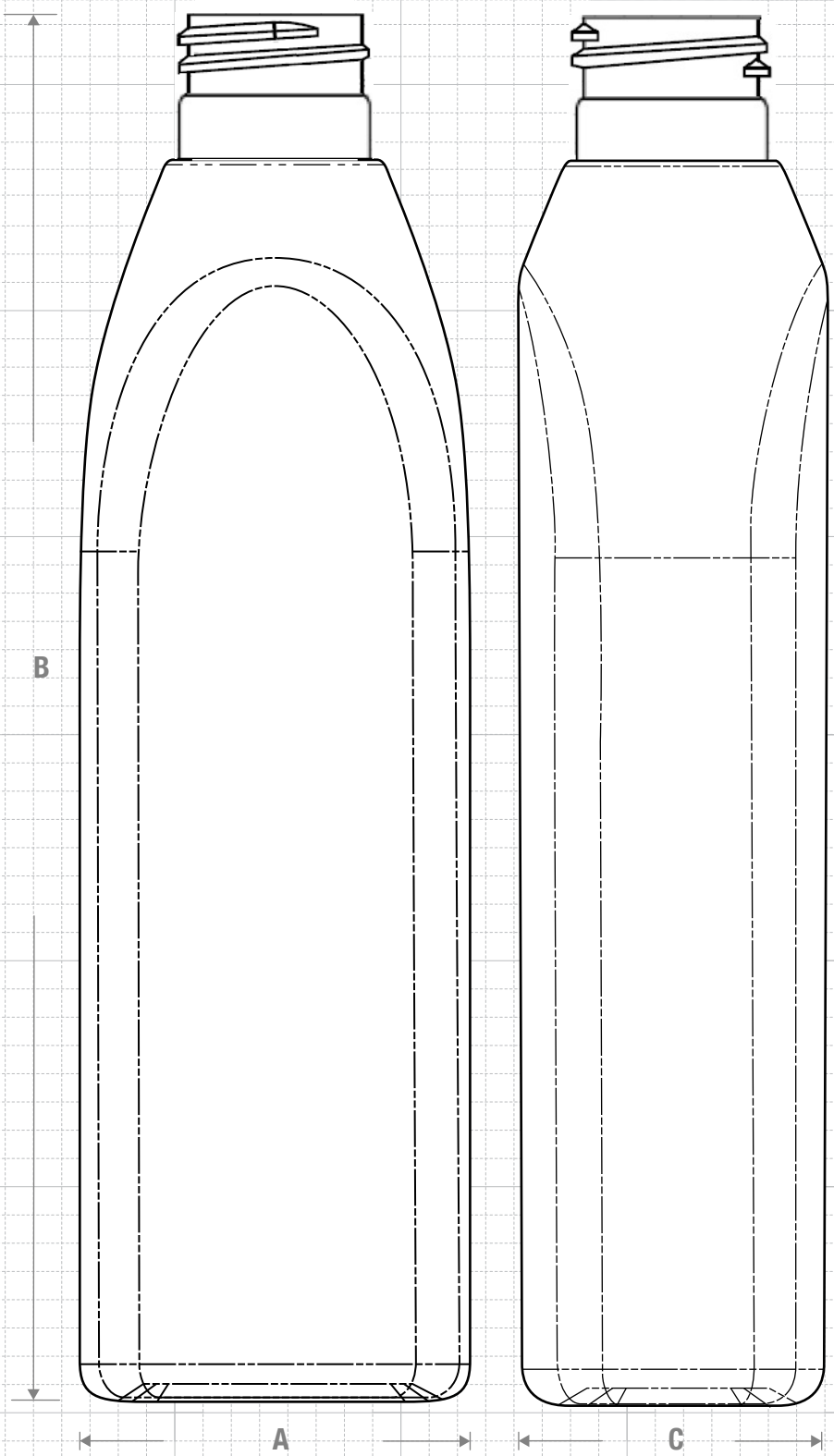

BOTTOM VIEW

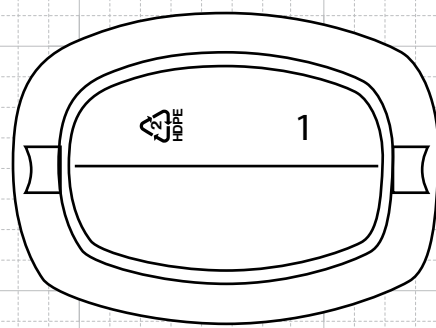

CLASSIC CONTAINERS INC
 1700 S. Hellman Ave.
 Ontario, CA 91761
 Phone: 909-930-3610
 e-mail: info@classiccontainers.com
 www.classiccontainers.com

| | | | |
|--|--|--|---|
| Drawing: 300 ml Allure 28/410 Spl | Gram Weight: 24.0 ± 2 | Max Print Area (Height): 5.532" | Cases Per Pallet: 16 |
| Stock Code: 030001123S0000 | Neck Finish: 28/410 Spl | Max Print Area (Width): 1.300"/ 0.687" | Box Dimensions: 24 7/16 x 18 1/2 x 23 |
| Manufacturing Process: Extrusion Blow Molding | Base Width (A) Base Deep (C): 2.216± 0.050 1.733±0.050 | Case Pack: 360 | Stock Material: |
| Overflow Capacity: 316-333 ml (10.7 - 11.3 oz) | Overall Height (B): 7.790 ± 0.050 | Case Weight (lb): 22.0 ± 1.6 | Rev #0 10/2020 Drawing not exactly to size. |

