



Drawing:  
2 oz Royalty Round 20/415  
M-2

Stock Code:  
000200040210000

Manufacturing Process:  
Extrusion Blow Molding

Overflow Capacity:  
61.9 - 70.8 ml (2.1 - 2.4 oz)

Gram Weight:  
9.5 ± 1

Neck Finish:  
20/415

Base Width (A):  
1.360 ± 0.050

Overall Height (B):  
3.890 ± 0.050

Max Print Area (Height):  
2.375"

Max Print Area (Width):  
4.063"

Case Pack: 908

Case Weight (lb): 21.1 ± 2.0

Cases Per Pallet: 25

Box Dimensions:  
23 5/8 x 15 9/16 x 17

Stock Material:



**CLASSIC CONTAINERS INC**  
1700 S. Hellman Ave.  
Ontario, CA 91761  
Phone: 909-930-3610  
e-mail: info@classiccontainers.com  
www.classiccontainers.com



### FRONT VIEW

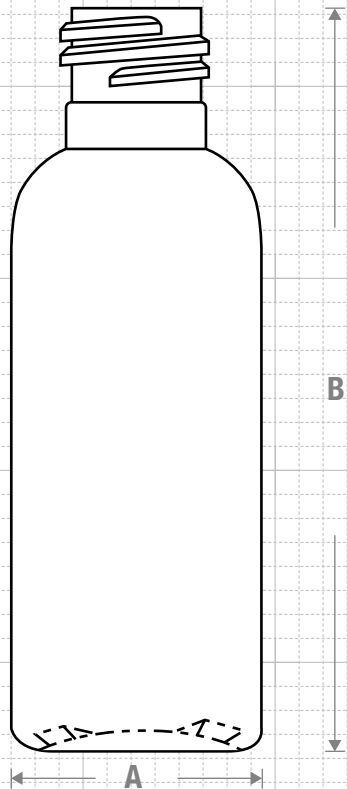

### NECK & THREAD DETAIL

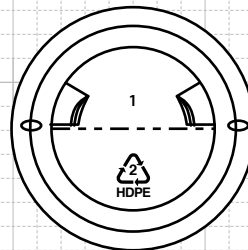
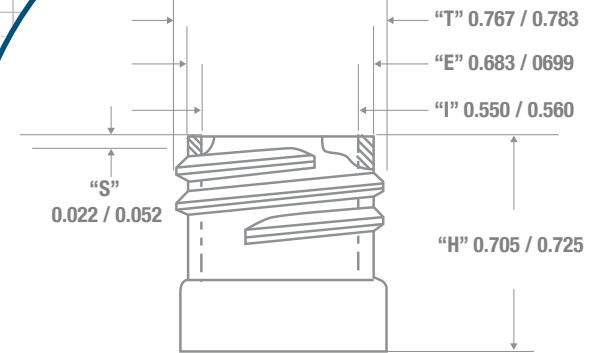

### BOTTOM VIEW

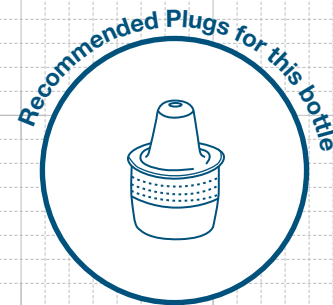

### FRICION FIT

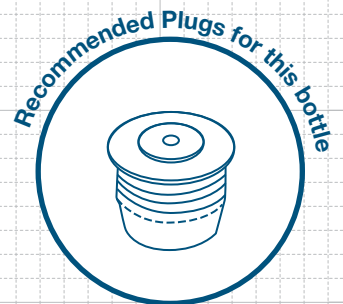

# PRINTING SPECIFICATIONS: 2 oz Royalty Round 20/415 M-2

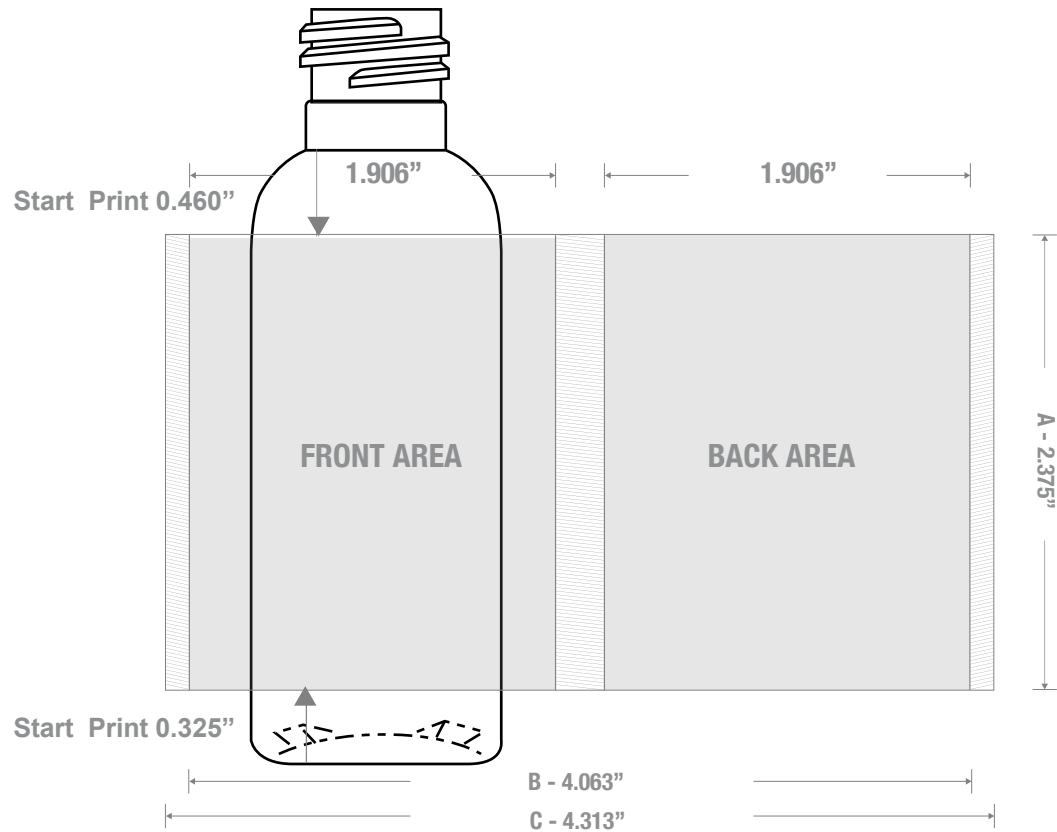

1700 S Hellman Ave, Ontario, California 91761  
Phone: (909) 930-3610 | Fax: (909) 930-3640  
e-mail: [info@classiccontainers.com](mailto:info@classiccontainers.com)  
[www.classiccontainers.com](http://www.classiccontainers.com)

**A - Total Height.**  
**B - Max. Decorating Area.**  
**C - Total bottle circumference.**  
☐ - Unprintable area.