

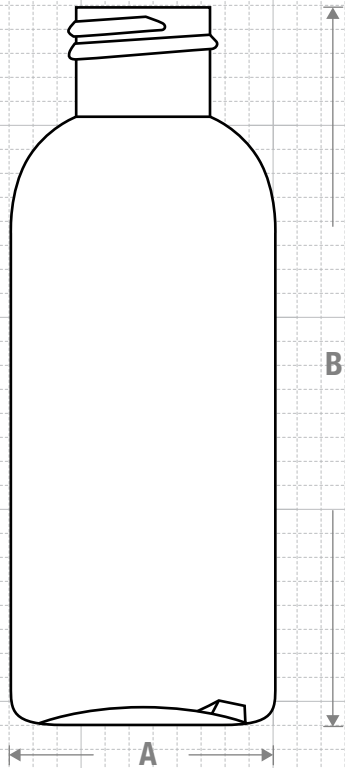

### FRONT VIEW

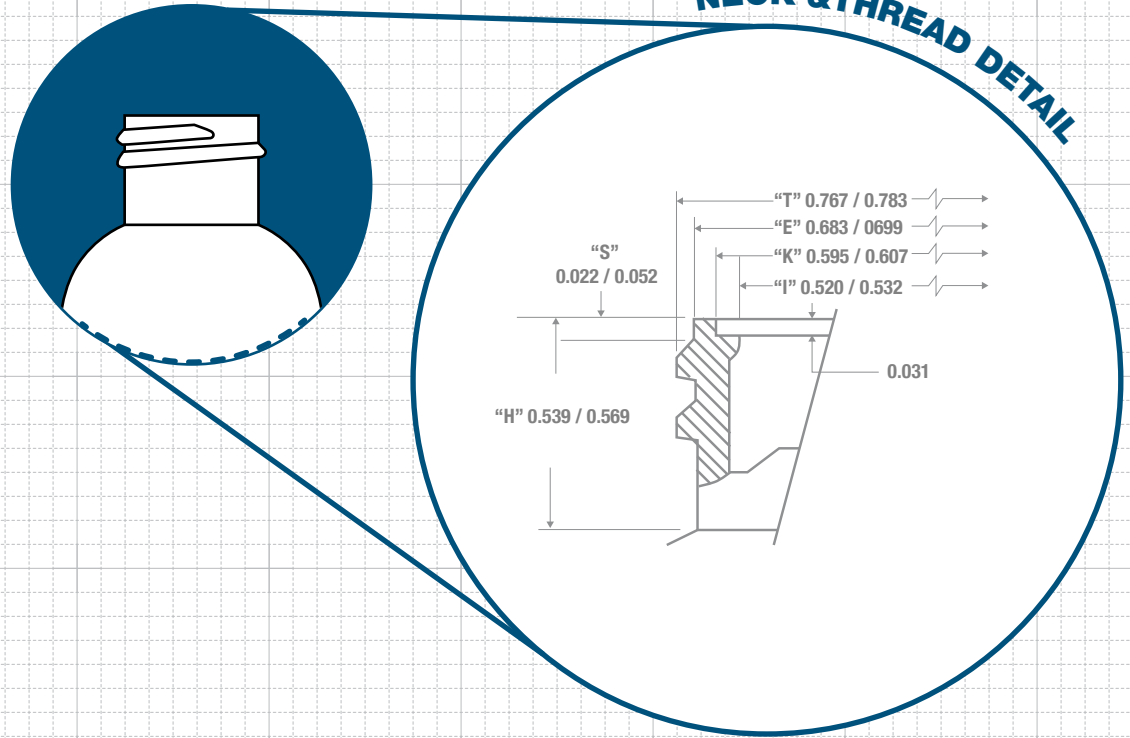

### NECK & THREAD DETAIL



Drawing:  
**2 oz Royalty Round 20/410  
IBM**

Stock Code:  
**00020004020000**

Manufacturing Process:  
**Injection Blow Molding**

Overflow Capacity:  
**62 - 71 ml (2.1 - 2.4 oz)**

Gram Weight:  
**8.7 ± 1**

Neck Finish:  
**20/410**

Base Width (A):  
**1.360 ± 0.050**

Overall Height (B):  
**3.665 ± 0.050**

Max Print Area (Height):  
**2.375"**

Max Print Area (Width):  
**4.063"**

Case Pack: **928**

Case Weight (lb): **19.9 ± 2.0**

Cases Per Pallet: **25**

Box Dimensions:  
**23 5/8 x 15 9/16 x 17**

Stock Material:

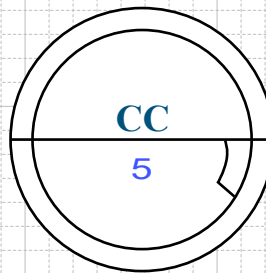

### BOTTOM VIEW

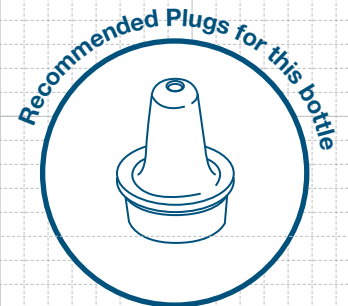
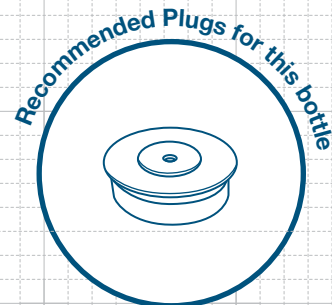

### SNAP FIT

**CLASSIC CONTAINERS INC**  
1700 S. Hellman Ave.  
Ontario, CA 91761  
Phone: 909-930-3610  
e-mail: info@classiccontainers.com  
[www.classiccontainers.com](http://www.classiccontainers.com)

# PRINTING SPECIFICATIONS: 2 oz Royalty Round 20/410

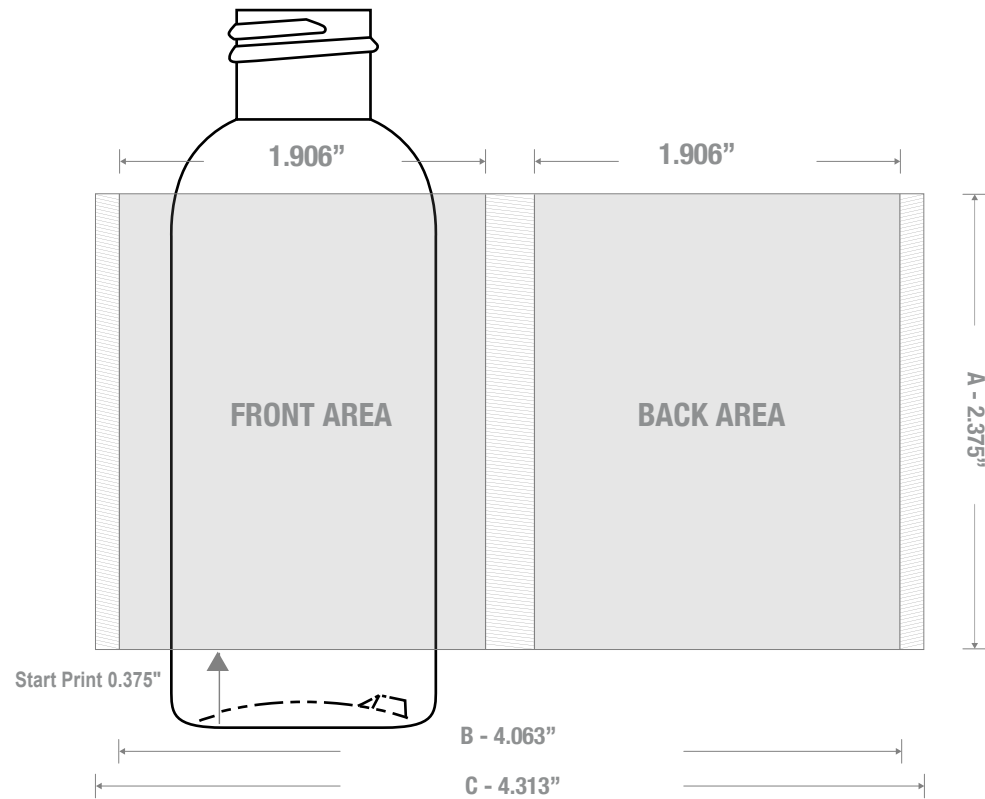

1700 S Hellman Ave, Ontario, California 91761  
Phone: (909) 930-3610 | Fax: (909) 930-3640  
e-mail: [info@classiccontainers.com](mailto:info@classiccontainers.com)  
[www.classiccontainers.com](http://www.classiccontainers.com)

**A - Total Height.**  
**B - Max. Decorating Area.**  
**C - Total bottle circumference.**  
▨ - Unprintable area.