



Drawing:
2 oz Imperial Round 20/415

Stock Code:
000200050210000

Manufacturing Process:
Extrusion Blow Molding

Overflow Capacity:
62- 68 ml (2.1 - 2.3 oz)

Gram Weight:
9.0 ± 1

Neck Finish:
20/415

Base Width (A):
1.280 ± 0.050

Overall Height (B):
4.200± 0.050

Max Print Area (Height):
2.500"

Max Print Area (Width):
3.812"

Case Pack: 980

Case Weight (lb): 21.6 ± 2.1

Cases Per Pallet: 25

Box Dimensions:
23 5/8 x15 9/16 x17

Stock Material:



CLASSIC CONTAINERS INC

1700 S. Hellman Ave.
Ontario, CA 91761

Phone: 909-930-3610

e-mail: info@classiccontainers.com

www.classiccontainers.com

FRONT VIEW

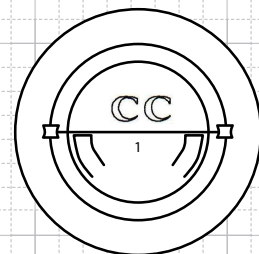
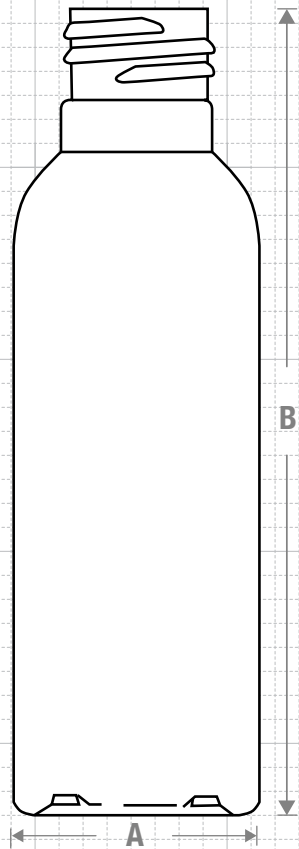

BOTTOM VIEW



NECK & THREAD DETAIL

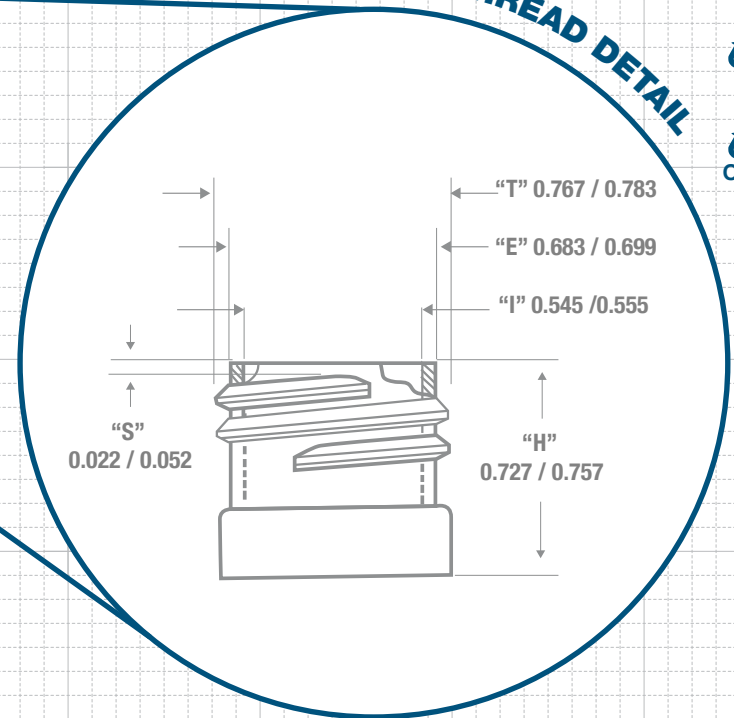

Recommended Plugs for this bottle



Recommended Plugs for this bottle



FRICITION FIT

PRINTING SPECIFICATIONS: 2 oz IMPERIAL ROUND 20/415

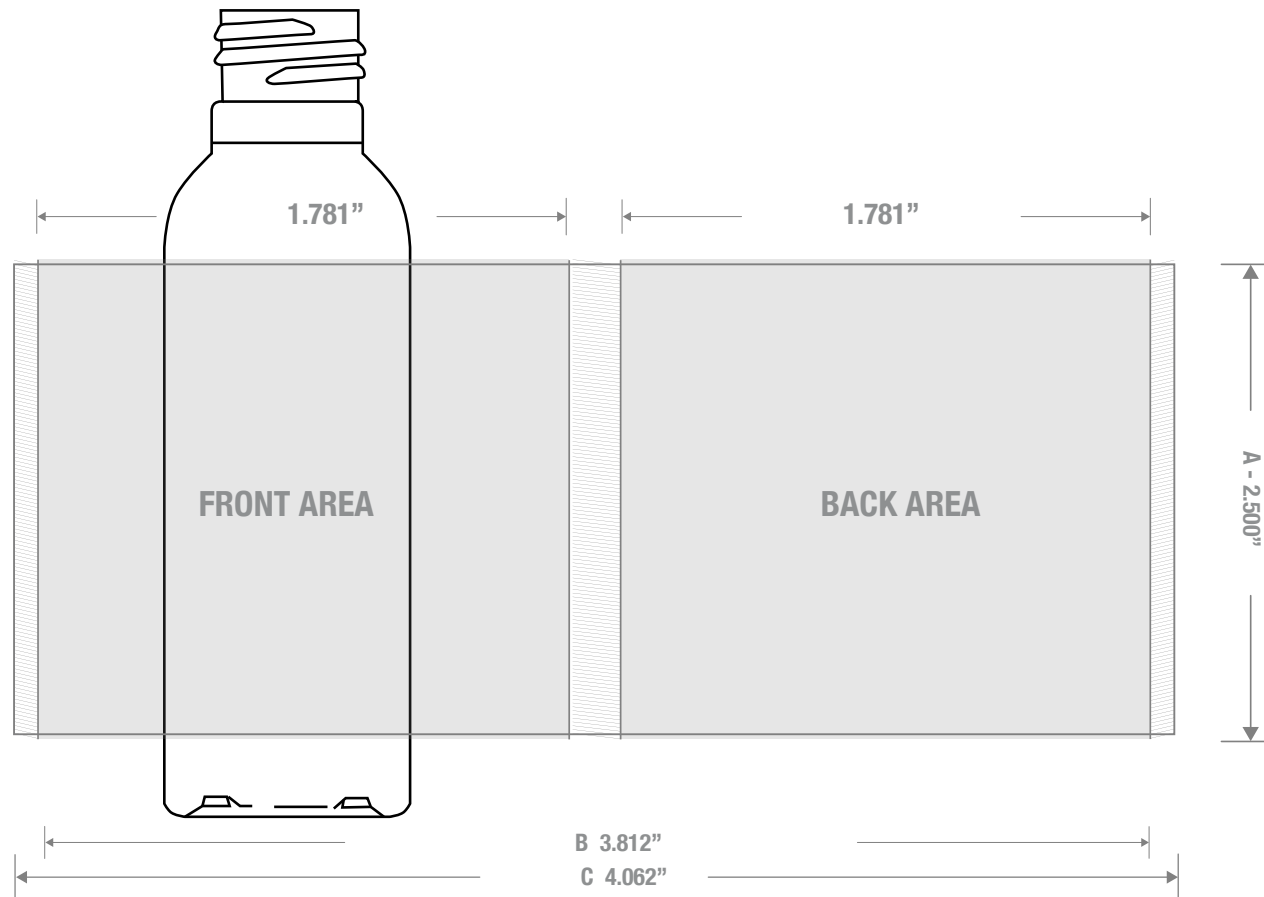

1700 S Hellman Ave, Ontario, California 91761
Phone: (909) 930-3610 | Fax: (909) 930-3640
e-mail: info@classiccontainers.com
www.classiccontainers.com

A - Total Height.
B - Max. Decorating Area.
C - Total bottle circumference.
▨ - Unprintable area.

LABELING SPECIFICATIONS: 2 oz IMPERIAL ROUND 20/415

FRONT AREA

BACK AREA



1700 S Hellman Ave, Ontario, California 91761
Phone: (909) 930-3610 | Fax: (909) 930-3640
e-mail: info@classiccontainers.com
www.classiccontainers.com

A - Total Height.
B - Total bottle circumference.