



Drawing:  
2 oz Evolution 20/410

Stock Code:  
000200330200000

Manufacturing Process:  
Extrusion Blow Molding

Overflow Capacity:  
62.0 - 71.0 ml (2.1 - 2.4 oz)

Gram Weight:  
8.5 ± 1

Neck Finish:  
20/410

Base Width (A):  
1.320 ± 0.050

Overall Height (B):  
4.000 ± 0.050

Max Print Area (Height):  
2.250"

Max Print Area (Width):  
3.875"

Case Pack: 884

Case Weight (lb): 18.7 ± 1.9

Cases Per Pallet: 25

Box Dimensions:  
23 5/8 x 15 9/16 x 17

Stock Material:



**CLASSIC CONTAINERS INC**  
1700 S. Hellman Ave.  
Ontario, CA 91761  
Phone: 909-930-3610  
e-mail: info@classiccontainers.com  
www.classiccontainers.com

### FRONT VIEW

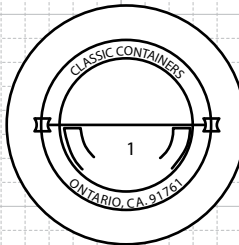
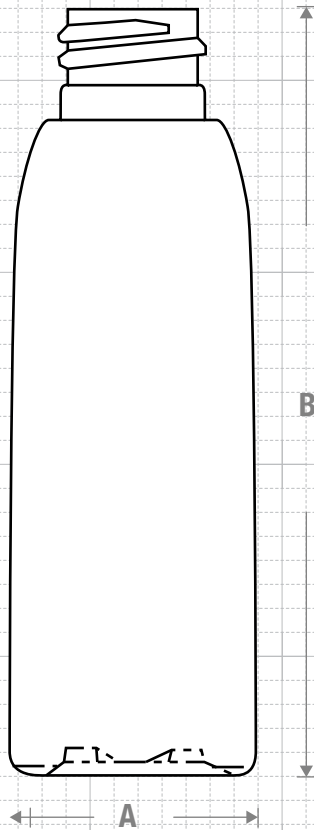

### BOTTOM VIEW

### NECK & THREAD DETAIL

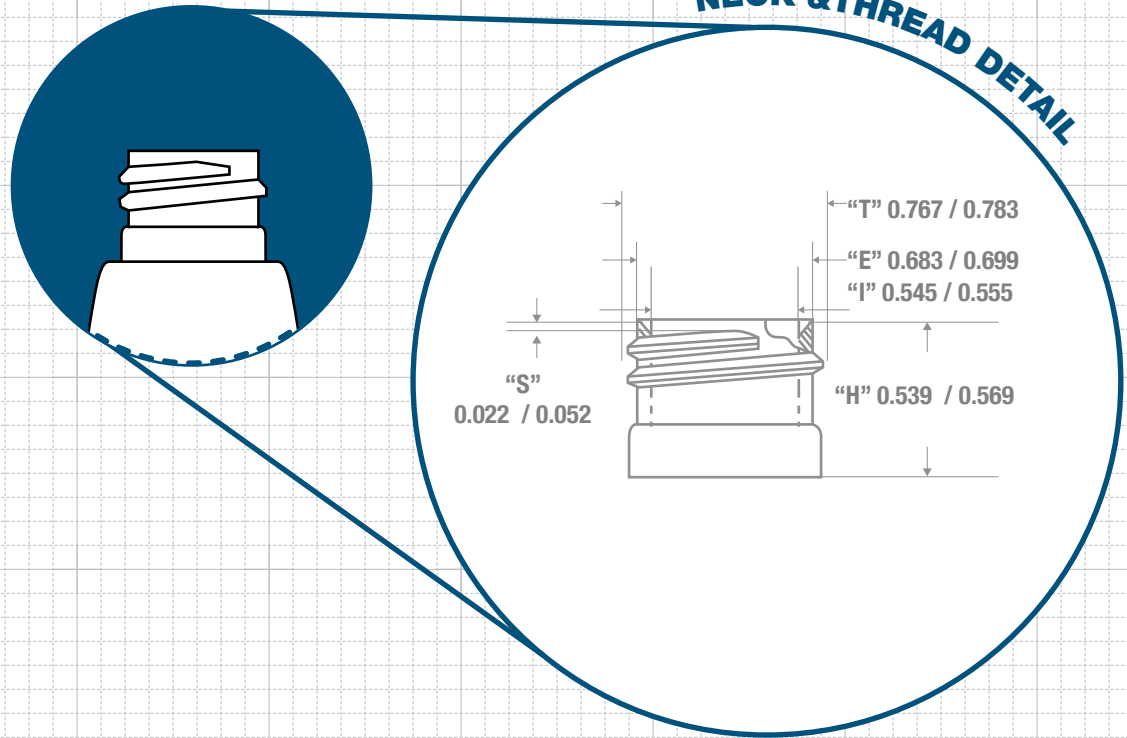

Recommended Plugs for this bottle



Recommended Plugs for this bottle



### FRICITION FIT



# PRINTING SPECIFICATIONS: 2 oz EVOLUTION 20/410

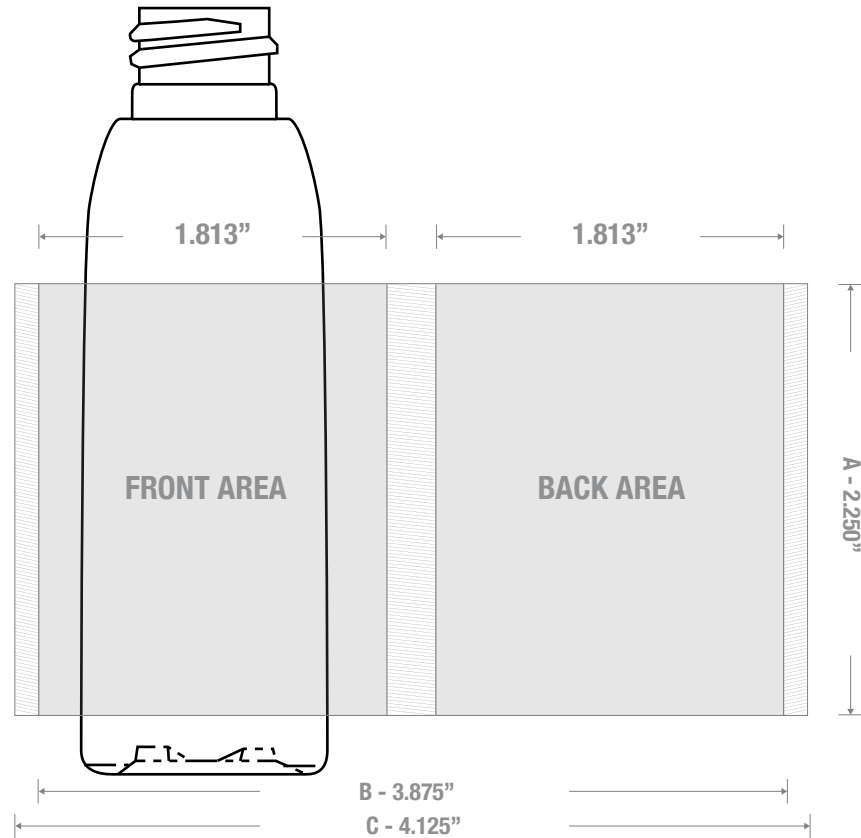

1700 S Hellman Ave, Ontario, California 91761  
Phone: (909) 930-3610 | Fax: (909) 930-3640  
e-mail: [info@classiccontainers.com](mailto:info@classiccontainers.com)  
[www.classiccontainers.com](http://www.classiccontainers.com)

A - Total Height.  
B - Max. Decorating Area.  
C - Total bottle circumference.  
▨ - Unprintable area.

# LABELING SPECIFICATIONS: 2 oz EVOLUTION 20/410

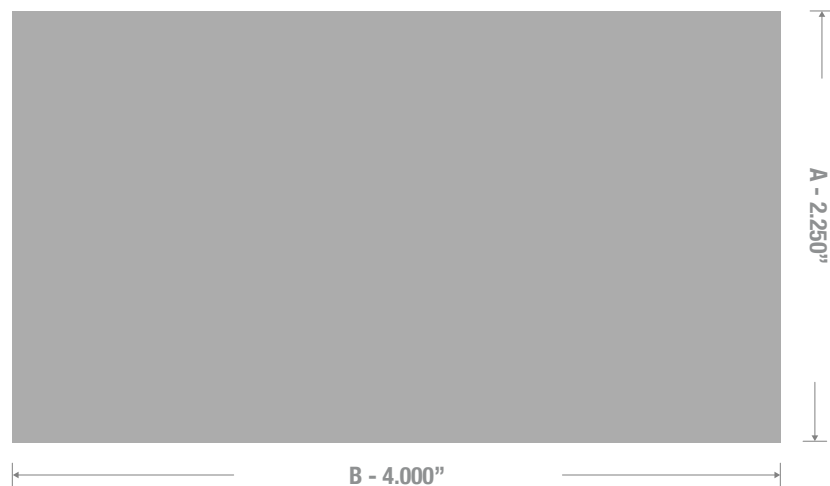

1700 S Hellman Ave, Ontario, California 91761  
Phone: (909) 930-3610 | Fax: (909) 930-3640  
e-mail: [info@classiccontainers.com](mailto:info@classiccontainers.com)  
[www.classiccontainers.com](http://www.classiccontainers.com)

**A - Total Height.**  
**B - Total bottle circumference.**