

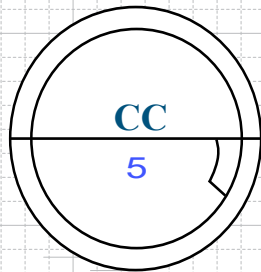

FRONT VIEW

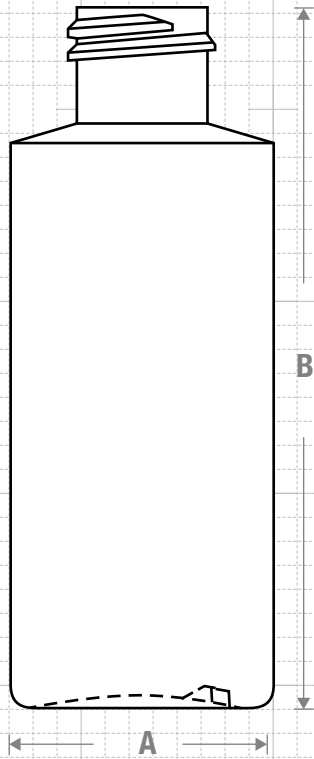

BOTTOM VIEW

NECK & THREAD DETAIL

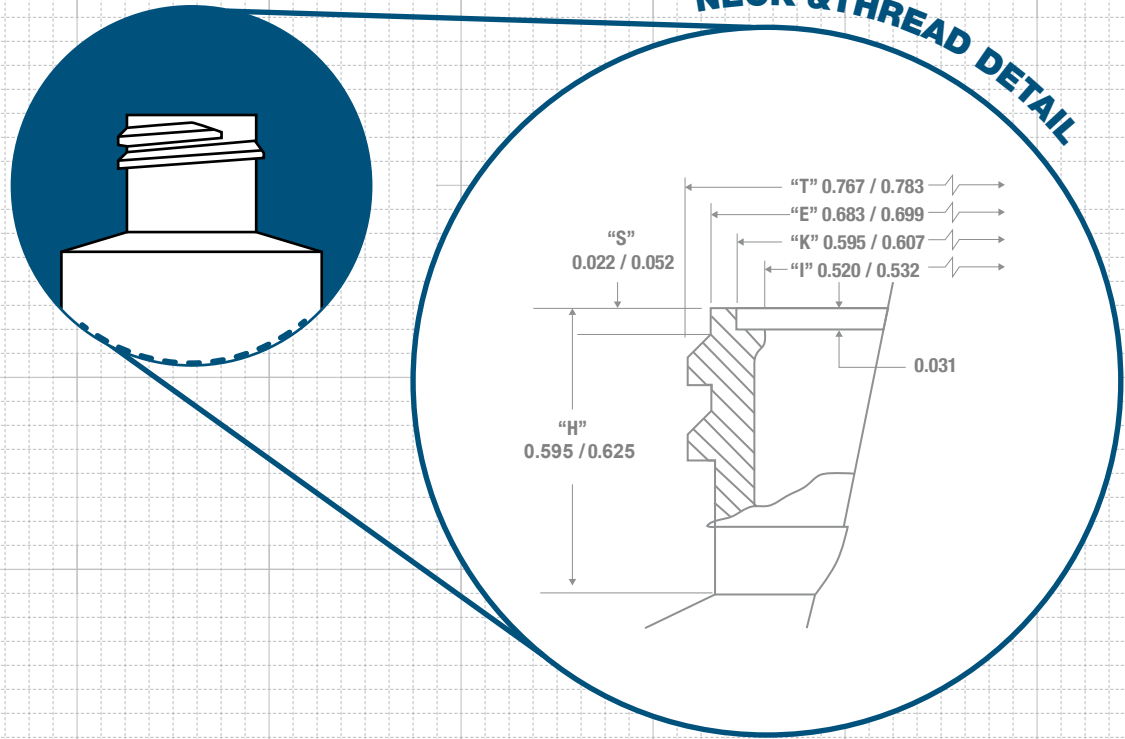

Recommended Plugs for this bottle

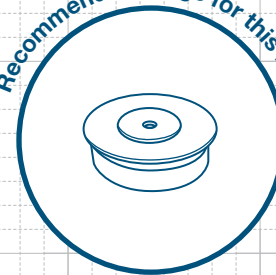

Recommended Plugs for this bottle



SNAP FIT



Drawing: 2 oz Cylinder Round 20/410

Stock Code: 00020001020000

Manufacturing Process: Injection Blow Molding

Overflow Capacity: 66.5 +/- 4.5 ml and 2.25 +/- 0.15 oz

Gram Weight: 9.5 ± 1

Neck Finish: 20/410

Base Width (A): 1.370 ± 0.050

Overall Height (B): 3.650 ± 0.050

Max Print Area (Height): 2.500"

Max Print Area (Width): 4.063"

Case Pack: 928

Case Weight (lb): 21.5 ± 2.0

Cases Per Pallet: 25

Box Dimensions: 23 5/8 x 15 9/16 x 17

Stock Material:



CLASSIC CONTAINERS INC
1700 S. Hellman Ave.
Ontario, CA 91761
Phone: 909-930-3610
e-mail: info@classiccontainers.com
www.classiccontainers.com

PRINTING SPECIFICATIONS: 2 oz CYLINDER ROUND 20/410

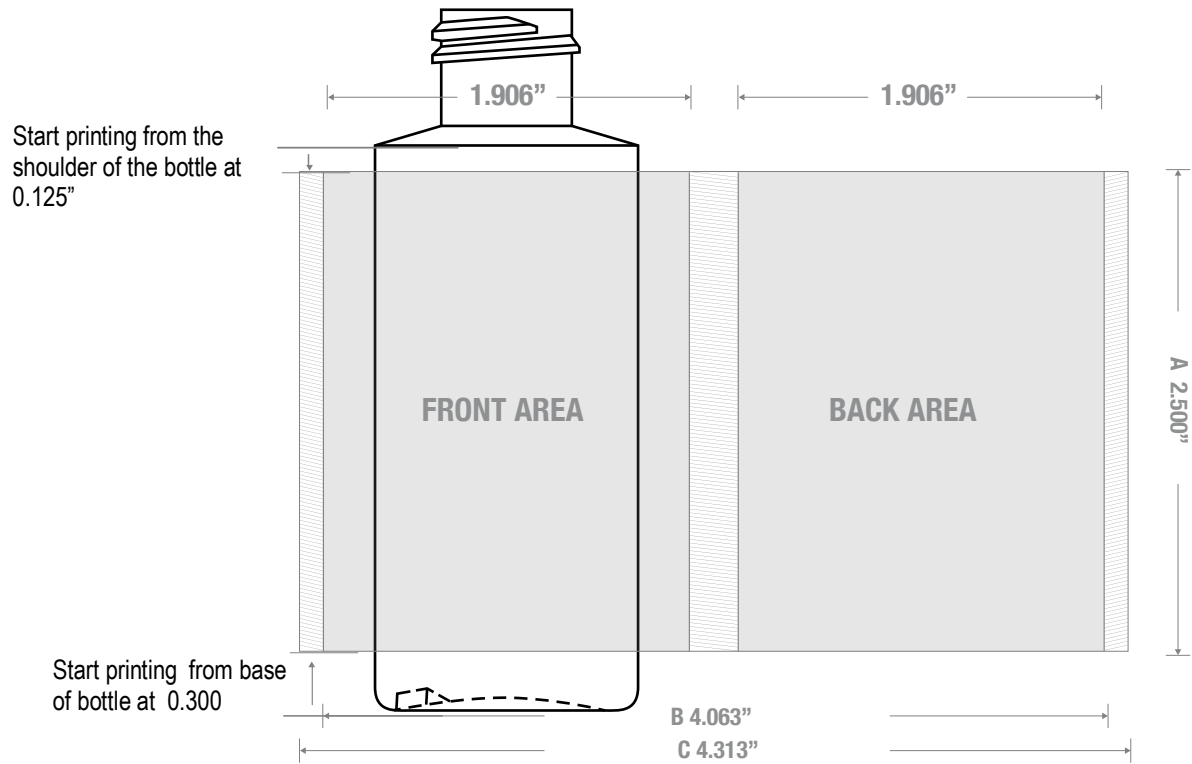

1700 S Hellman Ave, Ontario, California 91761
 Phone: (909) 930-3610 | Fax: (909) 930-3640
 e-mail: info@classiccontainers.com
www.classiccontainers.com

A - Total Height.
B - Max. Decorating Area.
C - Total bottle circumference.
 [Hatched Box] - Unprintable area.

LABELING SPECIFICATIONS: 2 oz CYLINDER ROUND 20/410



1700 S Hellman Ave, Ontario, California 91761
Phone: (909) 930-3610 | Fax: (909) 930-3640
e-mail: info@classiccontainers.com
www.classiccontainers.com

A - Total Height.
B - Total bottle circumference.