



Drawing:
2 oz Classic Oval 20/415

Stock Code:
000200230210000

Manufacturing Process:
Extrusion Blow Molding

Overflow Capacity:
65 - 74 ml (2.2 - 2.5 oz)

Gram Weight:
9.5 ± 1

Neck Finish:
20/415

Base Width (A): Base Depth (C)
1.610 ± 0.050 0.970 ± 0.050

Overall Height (B):
4.313 ± 0.005

Max Print Area (Height):
2.750"

Max Print Area (Width):
1.313"

Case Pack: 920

Case Weight (lb): 21.4 ± 2.0

Cases Per Pallet: 25

Box Dimensions:
23 5/8 x 15 9/16 x 17

Stock Material:



CLASSIC CONTAINERS INC
1700 S. Hellman Ave.
Ontario, CA 91761
Phone: 909-930-3610
e-mail: info@classiccontainers.com
www.classiccontainers.com

FRONT VIEW

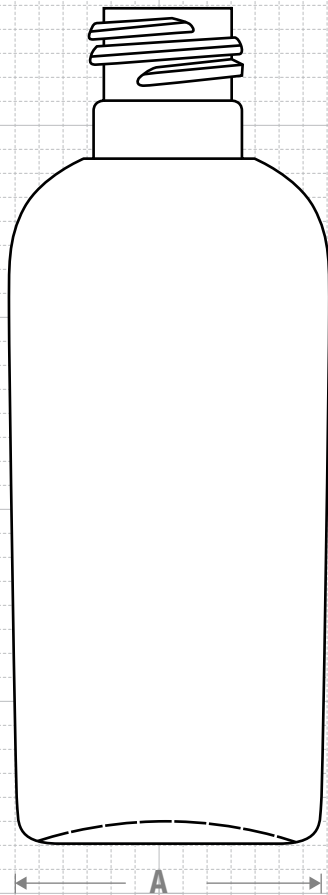

SIDE VIEW

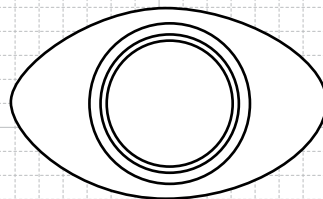
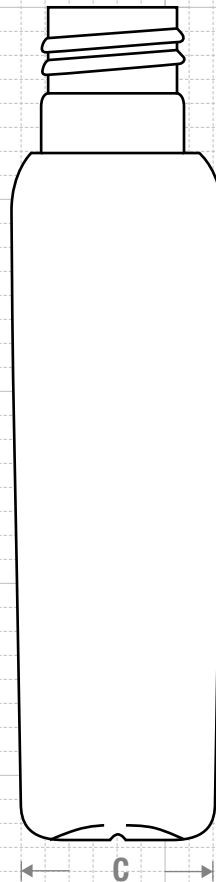

TOP VIEW

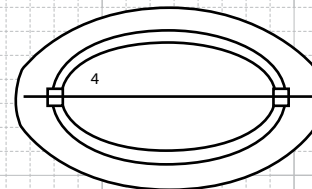

BOTTOM VIEW

NECK & THREAD DETAIL

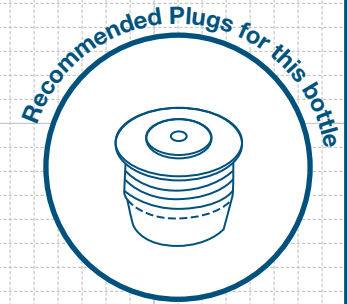
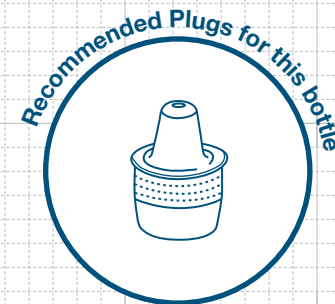
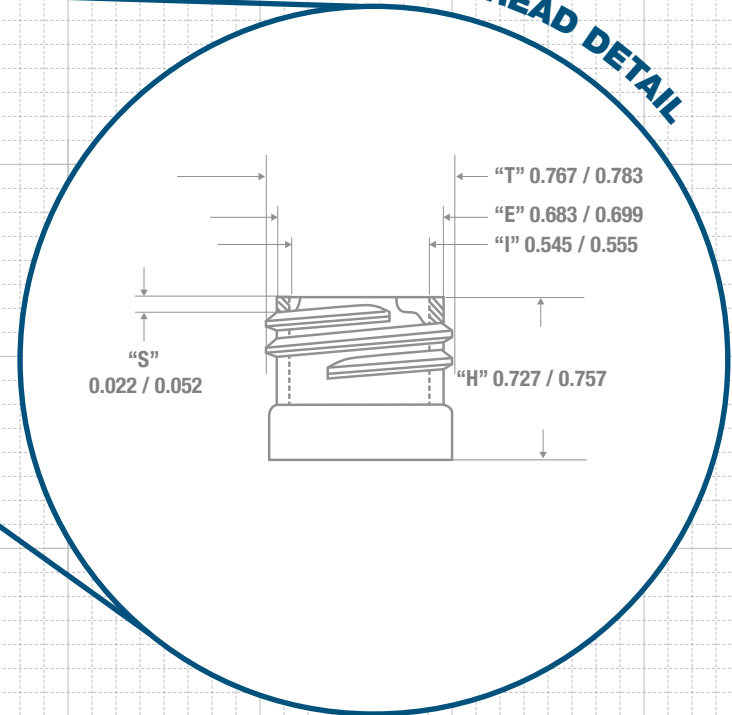

FRICION FIT



PRINTING SPECIFICATIONS: 2 oz CLASSIC OVAL 20/415

FRONT AREA

BACK AREA

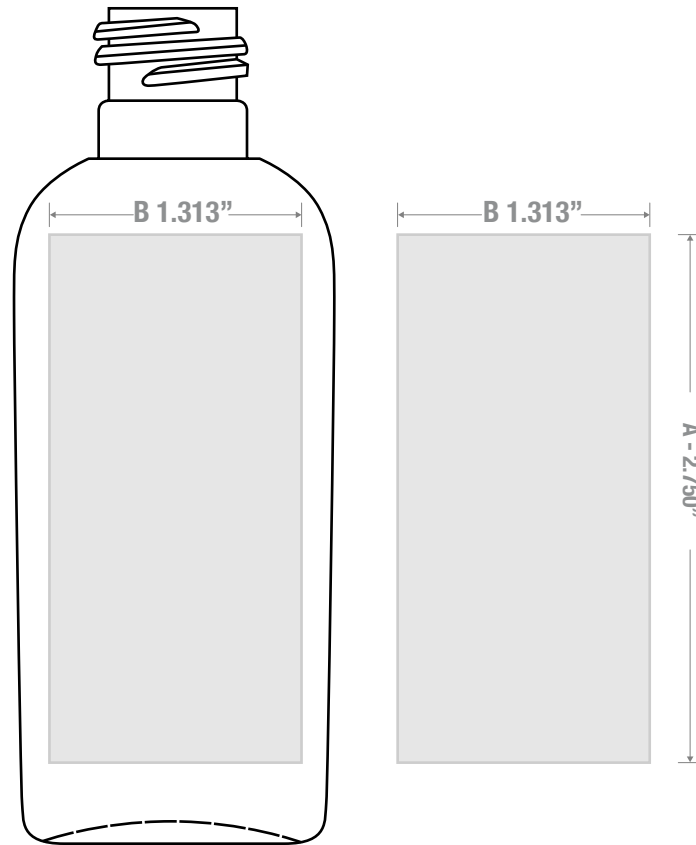

1700 S Hellman Ave, Ontario, California 91761
Phone: (909) 930-3610 | Fax: (909) 930-3640
e-mail: info@classiccontainers.com
www.classiccontainers.com

A - Total Height.
B - Max. Decorating Area.