



Drawing:  
2 oz Classic Oval 20/410

Stock Code:  
000200230200000

Manufacturing Process:  
Extrusion Blow Molding

Overflow Capacity:  
62 - 71 ml (2.1 - 2.4 oz)

Gram Weight:  
9.5± 1

Neck Finish:  
20/410

Base Width (A): Base Depth (C)  
1.610 ± 0.050 0.970 ± 0.050

Overall Height (B):  
4.130 ± 0.005

Max Print Area (Height):  
2.750"

Max Print Area (Width):  
1.313"

Case Pack: 920

Case Weight (lb): 21.3 ± 2.0

Cases Per Pallet: 25

Box Dimensions:  
23 5/8 x 15 9/16 x 17

Stock Material:



CLASSIC CONTAINERS INC  
1700 S. Hellman Ave.  
Ontario, CA 91761  
Phone: 909-930-3610  
e-mail: info@classiccontainers.com  
www.classiccontainers.com

### FRONT VIEW

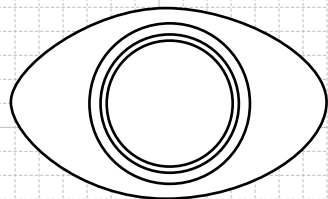
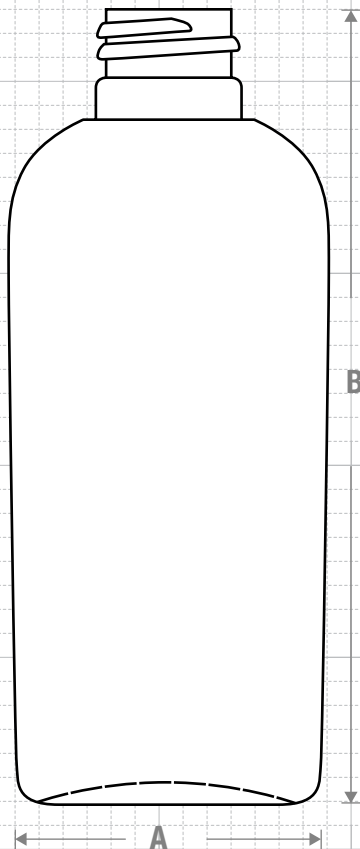

### TOP VIEW



### BOTTOM VIEW

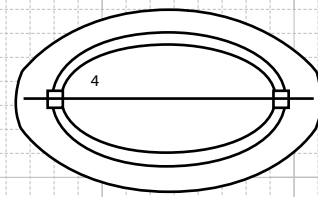

### NECK & THREAD DETAIL

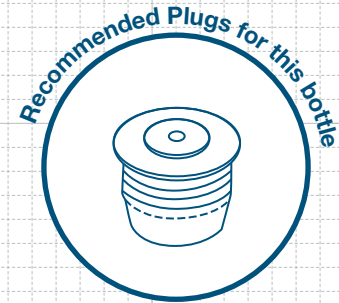
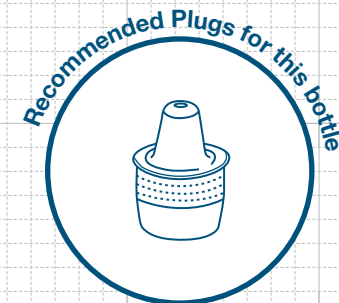
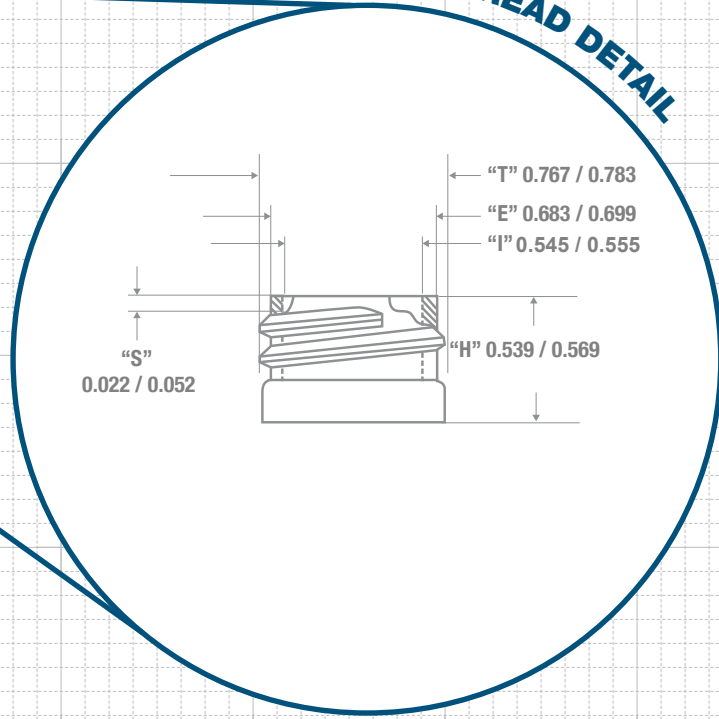

### FRICTION FIT



FRONT AREA

BACK AREA

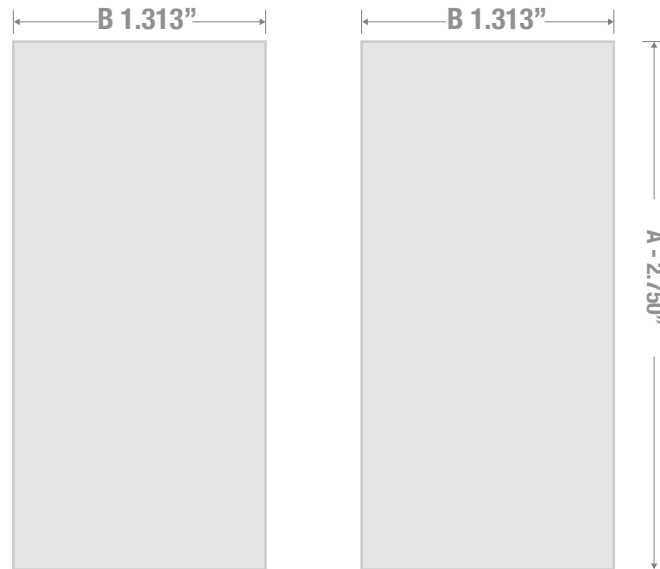

1700 S Hellman Ave, Ontario, California 91761  
Phone: (909) 930-3610 | Fax: (909) 930-3640  
e-mail: [info@classiccontainers.com](mailto:info@classiccontainers.com)  
[www.classiccontainers.com](http://www.classiccontainers.com)

**A - Total Height.**  
**B - Max. Decorating Area.**