

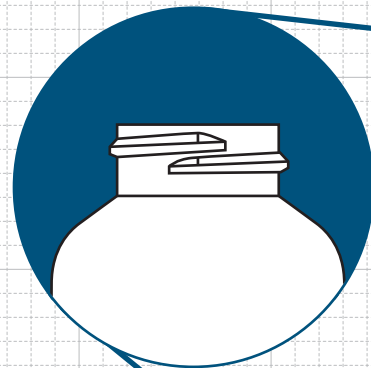

### FRONT VIEW

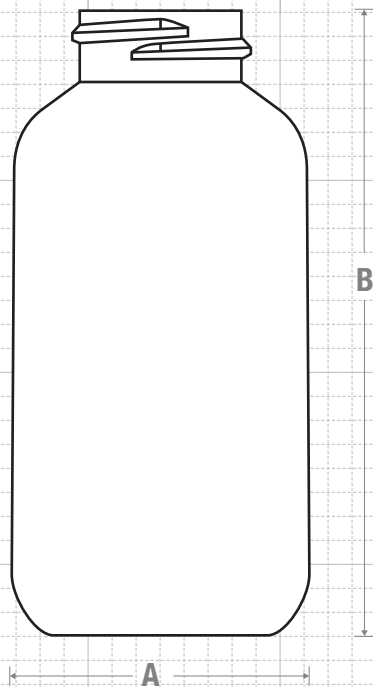

### NECK & THREAD DETAIL

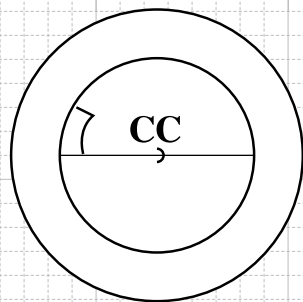
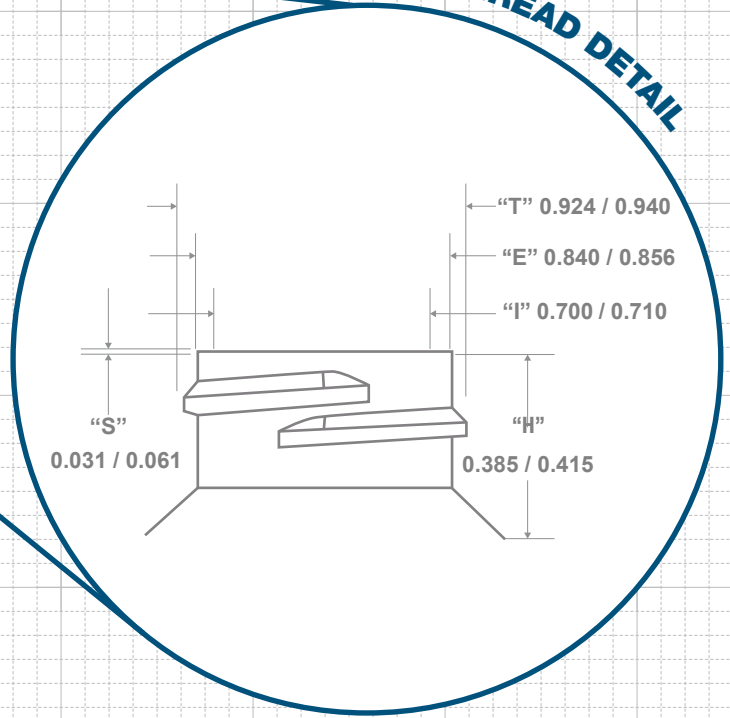

### BOTTOM VIEW

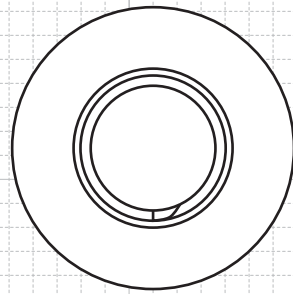

### TOP VIEW

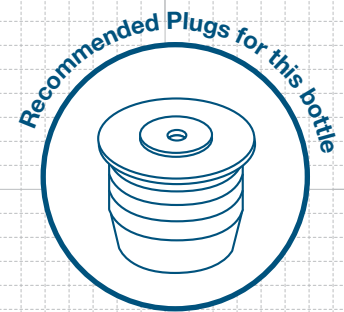

### FRICTION FIT

Drawing:  
**2 oz Boston Round  
24/400**

Stock Code:  
**000200060260000**

Manufacturing Process:  
**Extrusion Blow Molding**

Overflow Capacity:  
**71 - 77 ml (2.40 - 2.60 oz)**

Gram Weight:  
**8.5 ± 0.5**

Neck Finish:  
**24/400**

Base Width (A):  
**1.519 ± 0.050**

Overall Height (B):  
**3.215 ± 0.050**

Max Print Area (Height):  
**1.875"**

Max Print Area (Width):  
**4.563"**

Case Pack: **855**

Case Weight (lb): **18.2 ± 1.0**

Cases Per Pallet: **25**

Box Dimensions:  
**24 x 17 x 16**

Stock Material:



### CLASSIC CONTAINERS INC

1700 S. Hellman Ave.  
Ontario, CA 91761  
Phone: 909-930-3610  
e-mail: info@classiccontainers.com  
[www.classiccontainers.com](http://www.classiccontainers.com)

# PRINTING SPECIFICATIONS: 2 oz BOSTON ROUND 24/400

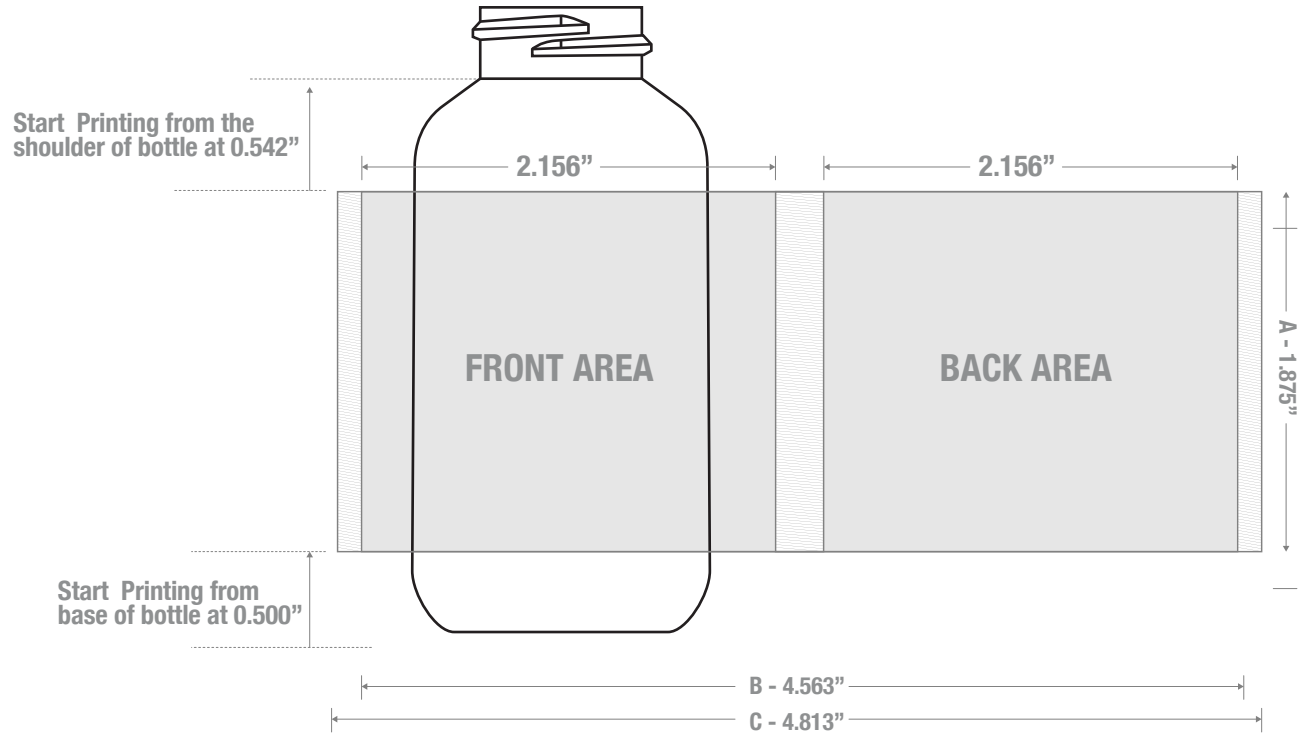

1700 S Hellman Ave, Ontario, California 91761  
Phone: (909) 930-3610 | Fax: (909) 930-3640  
e-mail: [info@classiccontainers.com](mailto:info@classiccontainers.com)  
[www.classiccontainers.com](http://www.classiccontainers.com)

**A - Total Height.**  
**B - Max. Decorating Area.**  
**C - Total bottle circumference.**  
☒ - Unprintable area.

# LABELING SPECIFICATIONS: 2 oz BOSTON ROUND 24/400



1700 S Hellman Ave, Ontario, California 91761  
Phone: (909) 930-3610 | Fax: (909) 930-3640  
e-mail: [info@classiccontainers.com](mailto:info@classiccontainers.com)  
[www.classiccontainers.com](http://www.classiccontainers.com)

**A - Total Height.**  
**B - Max. Decorating Area.**