

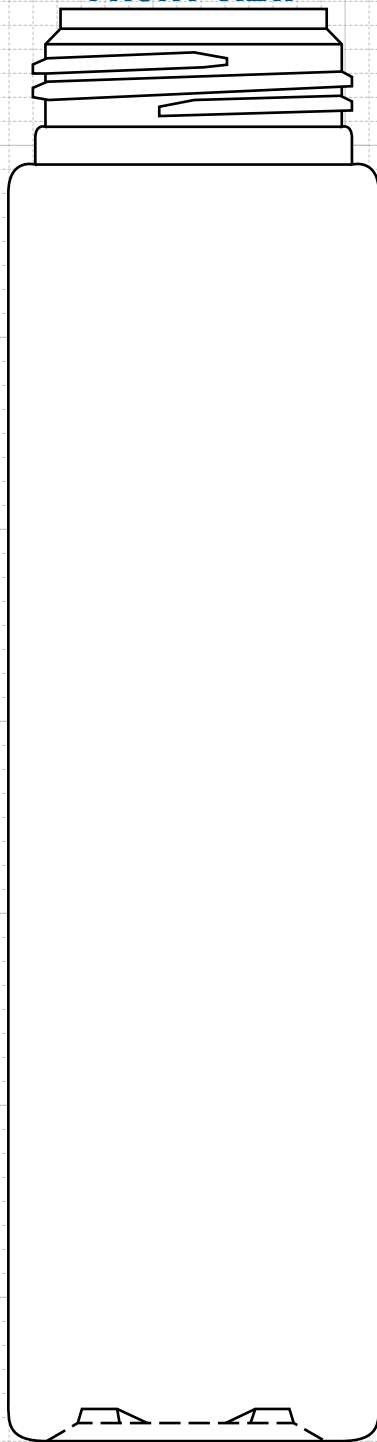

FRONT VIEW



Drawing:
250 ml Classic Foamer
43 mm

Stock Code:
025000200430000

Manufacturing Process:
Extrusion Blow Molding

Overflow Capacity:
301 - 319 ml (10.2 - 10.8 oz)

Gram Weight:
30 ± 2

Neck Finish:
43 mm

Base Width (A):
1.930 ± 0.050

Overall Height (B):
7.459 ± 0.050

Max Print Area (Height):
6.000"

Max Print Area (Width):
5.750"

Case Pack: 396

Case Weight (lb): 29.0 ± 1.7

Cases Per Pallet: 16

Box Dimensions:
24⁷/₁₆ x 18¹/₂ x 23

Stock Material:



CLASSIC CONTAINERS INC
1700 S. Hellman Ave.
Ontario, CA 91761
Phone: 909-930-3610
e-mail: info@classiccontainers.com
www.classiccontainers.com

NECK & THREAD DETAIL

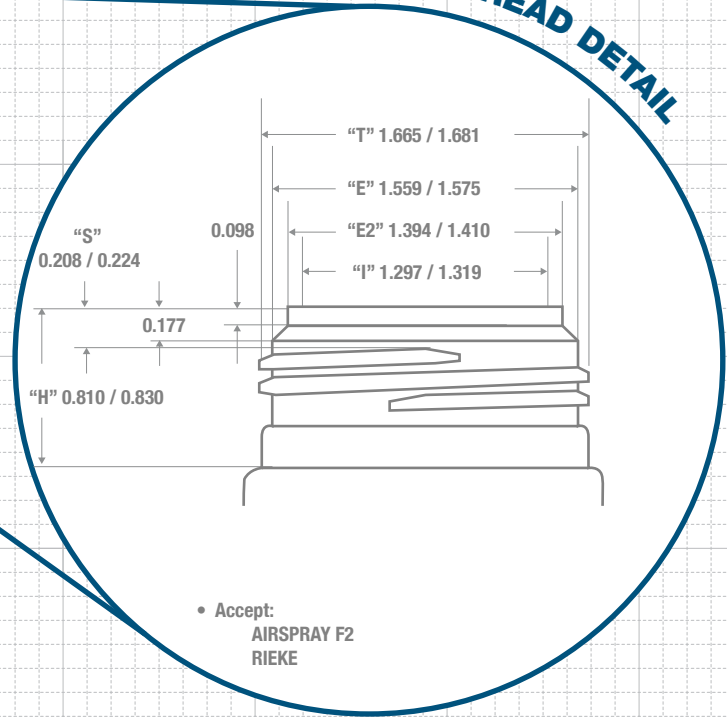
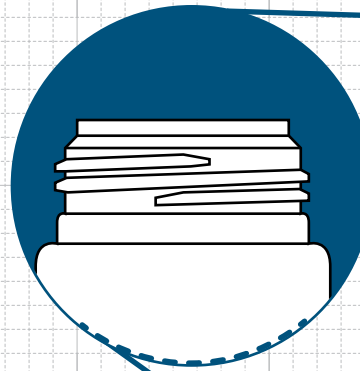

B

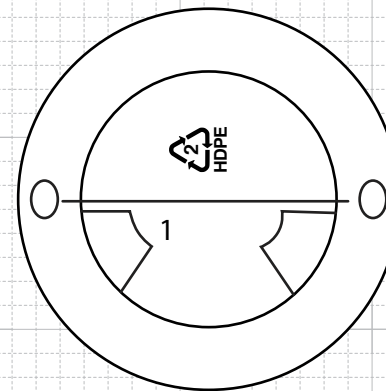

BOTTOM VIEW

A



PRINTING SPECIFICATIONS: 250 ml CLASSIC FOAMER 43 mm

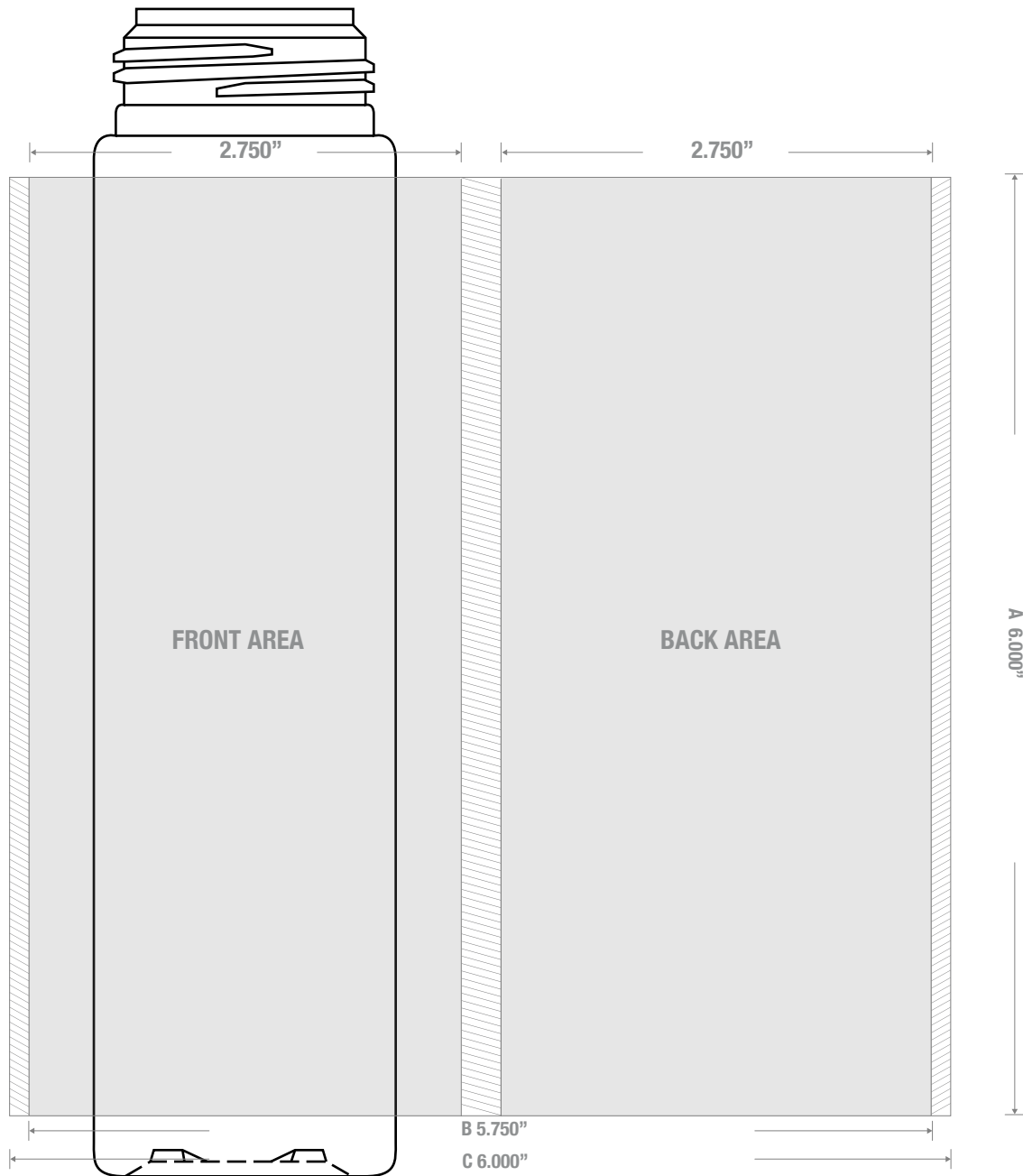

1700 S Hellman Ave, Ontario, California 91761
Phone: (909) 930-3610 | Fax: (909) 930-3640
e-mail: info@classiccontainers.com
www.classiccontainers.com

A - Total Height.
B - Max. Decorating Area.
C - Total bottle circumference.
▨ - Unprintable area.

LABELING SPECIFICATIONS: 250 ml CLASSIC FOAMER 43 mm

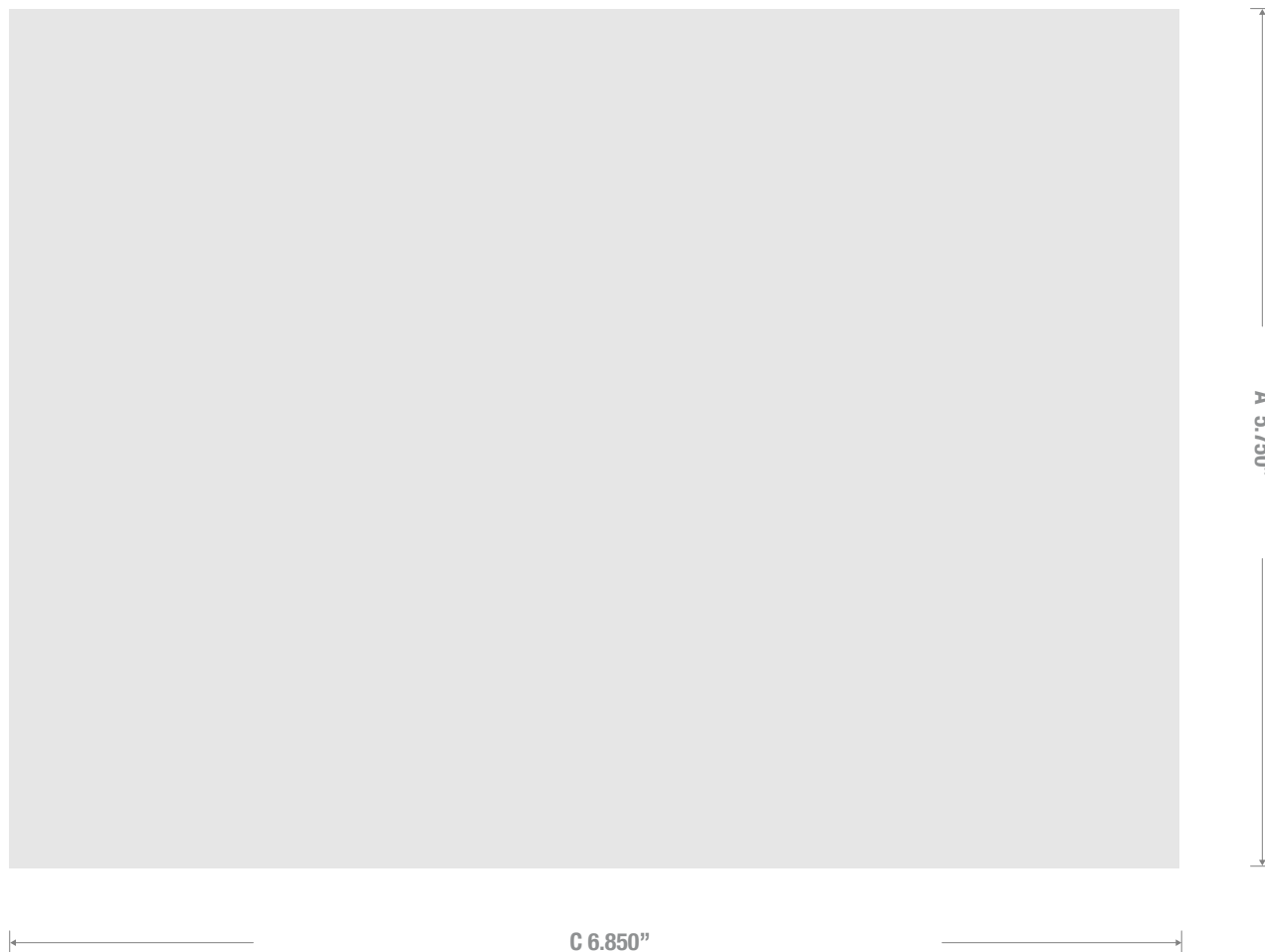

1700 S Hellman Ave, Ontario, California 91761
Phone: (909) 930-3610 | Fax: (909) 930-3640
e-mail: info@classiccontainers.com
www.classiccontainers.com

A - Total Height.
B - Total bottle circumference.