



Drawing:  
225 ml Cylinder Slim Tall  
24/410

Stock Code:  
022500870241700

Manufacturing Process:  
Stretch Blow Molding

Overflow Capacity:  
225 -236 ml (7.6 - 8.0 oz)

Gram Weight:  
20 ± 1

Neck Finish:  
24/410

Base Width (A):  
1.732 ± 0.050

Overall Height (B):  
6.903 ± 0.050

Max Print Area (Height):  
5.531"

Max Print Area (Width):  
5.188"

Case Pack: 521

Case Weight (lb): 25.9 ± 1.1

Cases Per Pallet: 16

Box Dimensions:  
24 7/16 x 18 1/2 x 23

Stock Material:



**CLASSIC CONTAINERS INC**  
1700 S. Hellman Ave.  
Ontario, CA 91761  
Phone: 909-930-3610  
e-mail: info@classiccontainers.com  
www.classiccontainers.com

### FRONT VIEW

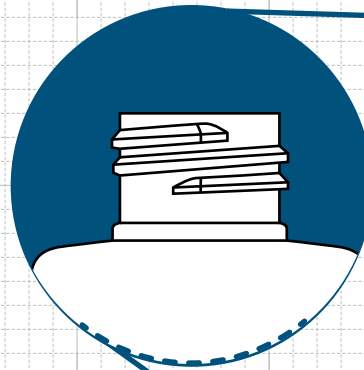
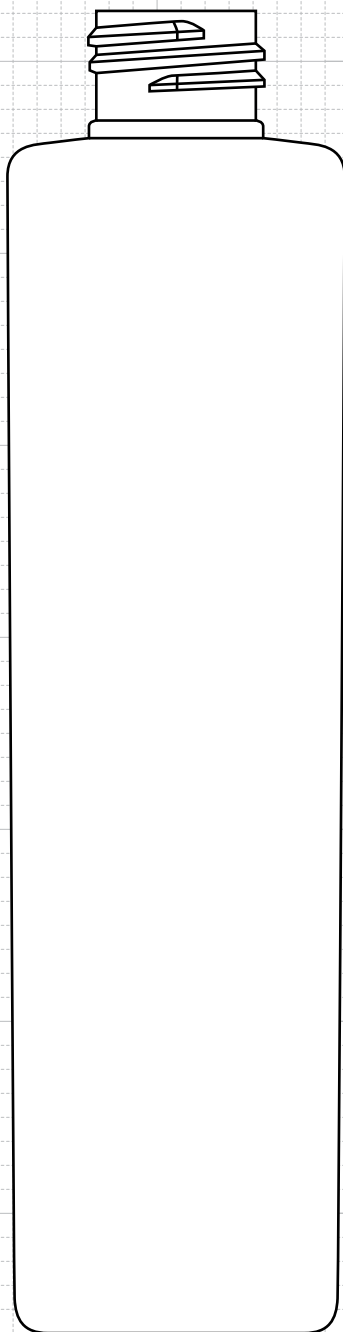

### NECK & THREAD DETAIL

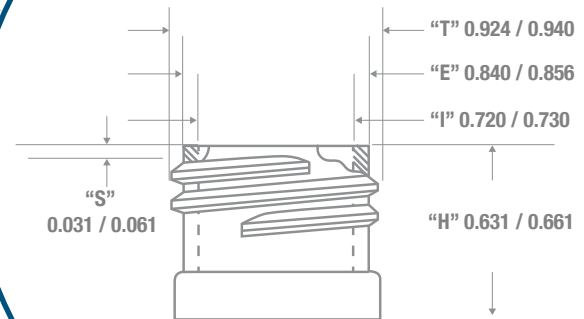

B

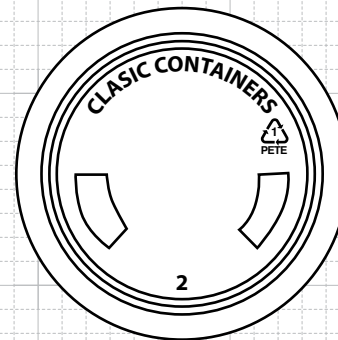

### BOTTOM VIEW

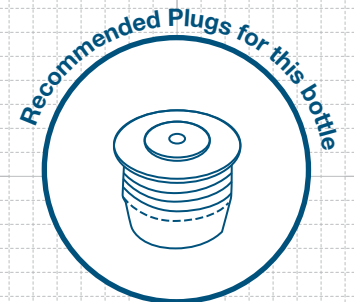

### FRICITION FIT

# PRINTING SPECIFICATIONS: 225 ml Cylinder Slim Tall 24/410

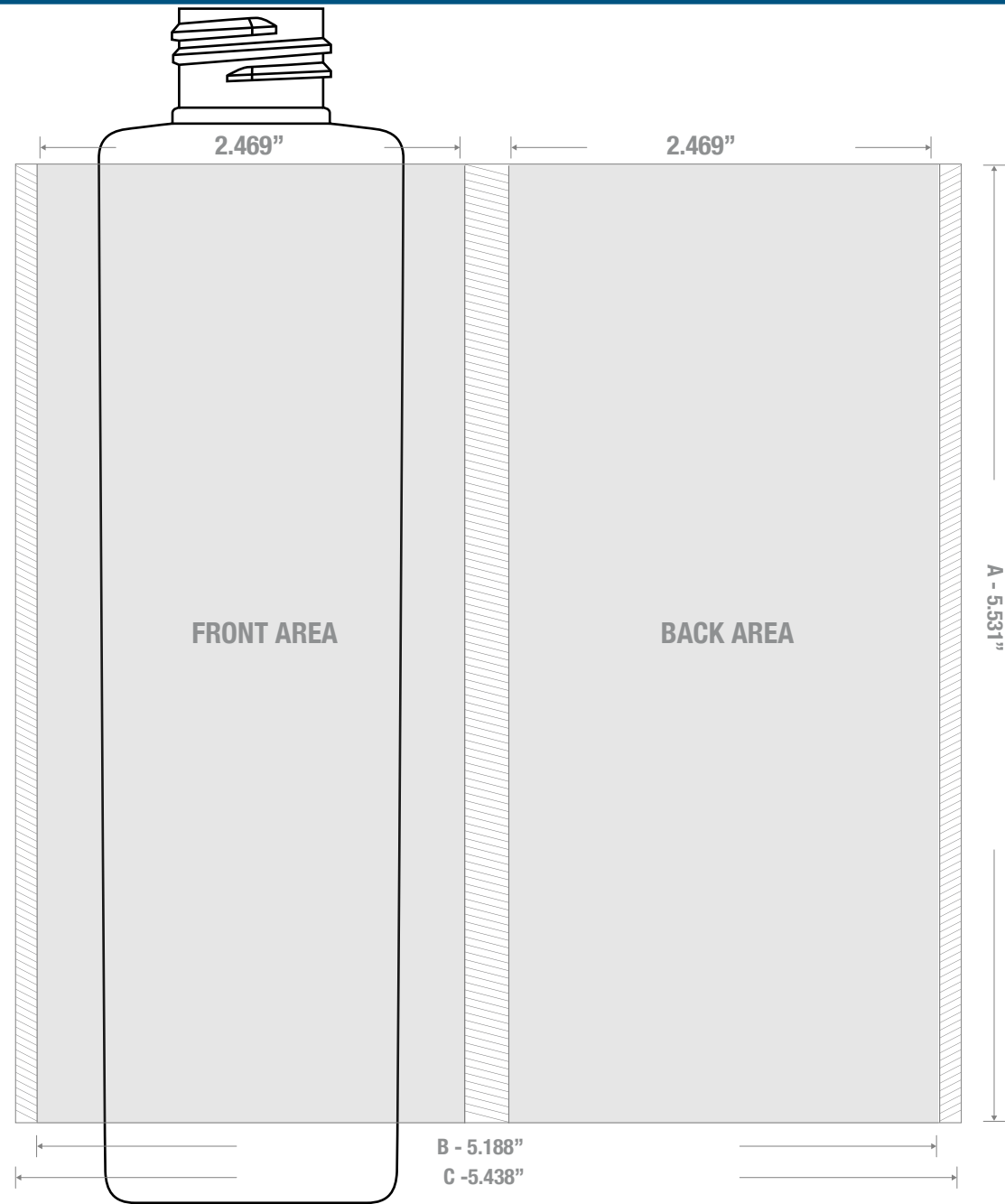

1700 S Hellman Ave, Ontario, California 91761  
Phone: (909) 930-3610 | Fax: (909) 930-3640  
e-mail: [info@classiccontainers.com](mailto:info@classiccontainers.com)  
[www.classiccontainers.com](http://www.classiccontainers.com)

**A - Total Height.**  
**B - Max. Decorating Area.**  
**C - Total bottle circumference.**  
▨ - Unprintable area.