

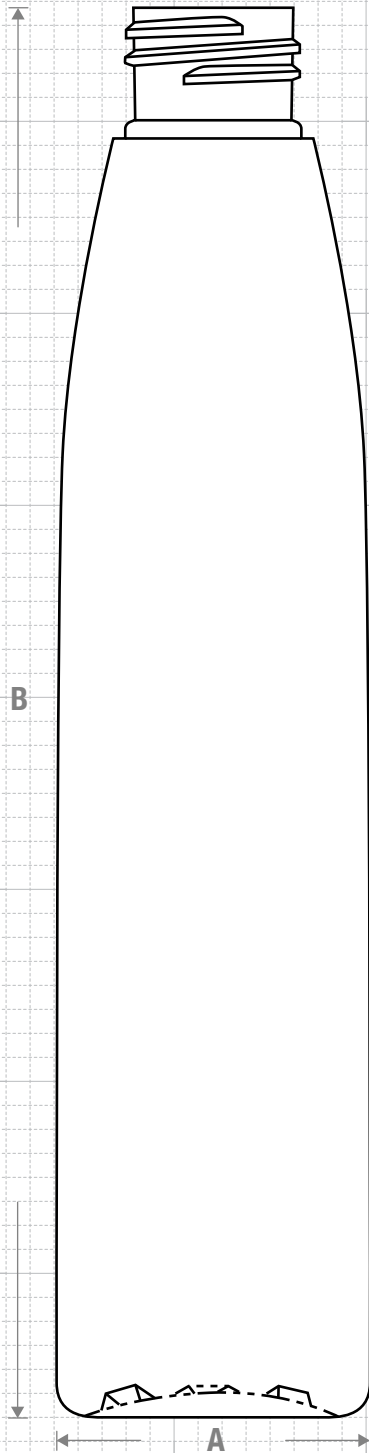

# FRONT VIEW



Drawing:  
200 ml Evolution Slim 24/410

Stock Code:  
020000470240000

Manufacturing Process:  
Stretch Blow Molding

Overflow Capacity:  
204 - 215 ml (6.9 - 7.3 oz)

Gram Weight:  
20 ± 1

Neck Finish:  
24/410

Base Width (A):  
1.675 ± 0.050

Overall Height (B):  
7.396 ± 0.050

Max Print Area (Height):  
4.180"

Max Print Area (Width):  
5.053"

Case Pack: 504

Case Weight (lb): 25.1 ± 1.1

Cases Per Pallet: 16

Box Dimensions:  
24 7/16 x 18 1/2 x 23

Stock Material:



**CLASSIC CONTAINERS INC**  
1700 S. Hellman Ave.  
Ontario, CA 91761  
Phone: 909-930-3610  
e-mail: info@classiccontainers.com  
www.classiccontainers.com



# NECK & THREAD DETAIL

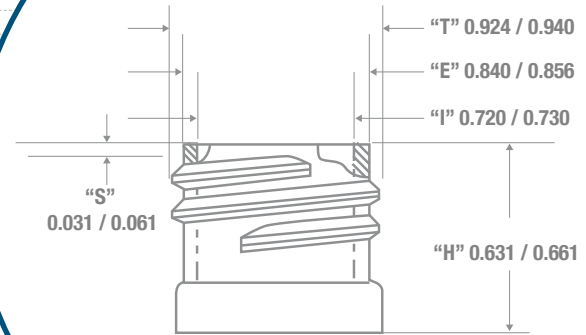

Recommended Plugs for this bottle

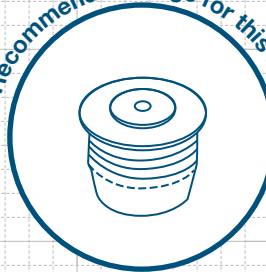

# FRICTION FIT

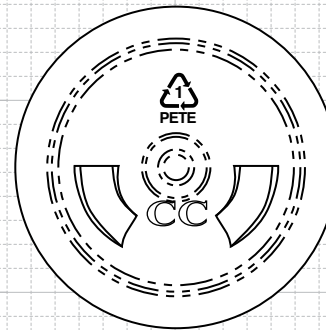

# BOTTOM VIEW

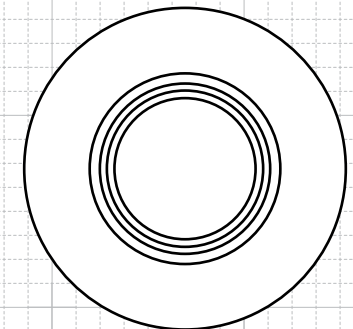

# TOP VIEW