



FRONT VIEW

Drawing:
200 ml Classic Foamer
43 mm Rieke

Stock Code:
020000200440000

Manufacturing Process:
Extrusion Blow Molding

Overflow Capacity:
257 - 271 ml (8.7 - 9.2 oz)

Gram Weight:
21 ± 2

Neck Finish:
43 mm Rieke

Base Width (A):
1.985 ± 0.050

Overall Height (B):
6.153 ± 0.050

Max Print Area (Height):
4.500"

Max Print Area (Width):
6.000"

Case Pack: 417

Case Weight (lb): 22.2 ± 1.8

Cases Per Pallet: 16

Box Dimensions:
24 7/16 x 18 1/2 x 23

Stock Material:



CLASSIC CONTAINERS INC
1700 S. Hellman Ave.
Ontario, CA 91761
Phone: 909-930-3610
e-mail: info@classiccontainers.com
www.classiccontainers.com

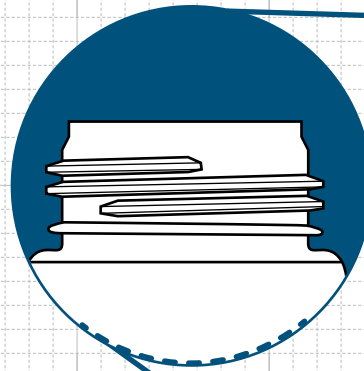
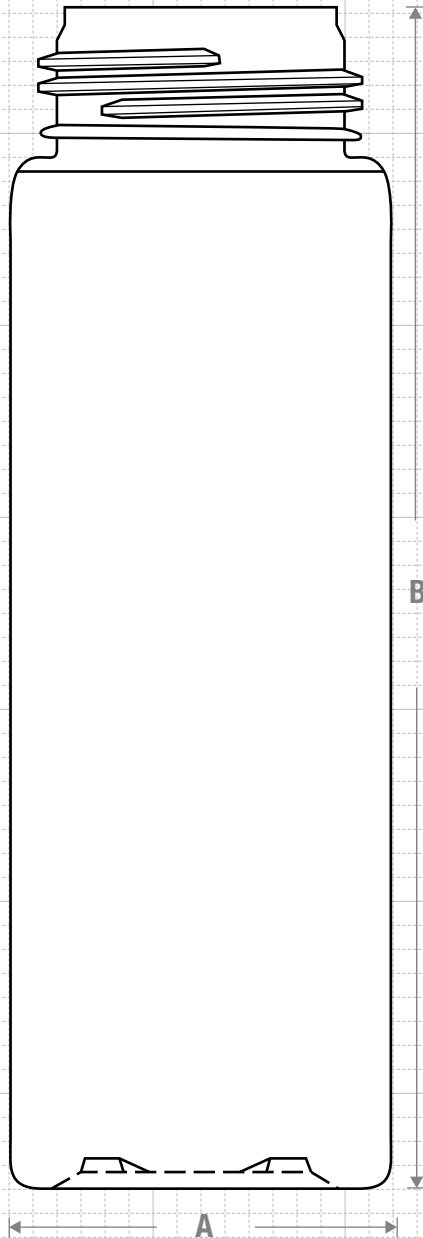

NECK & THREAD DETAIL

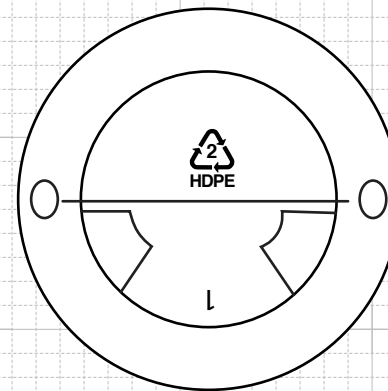
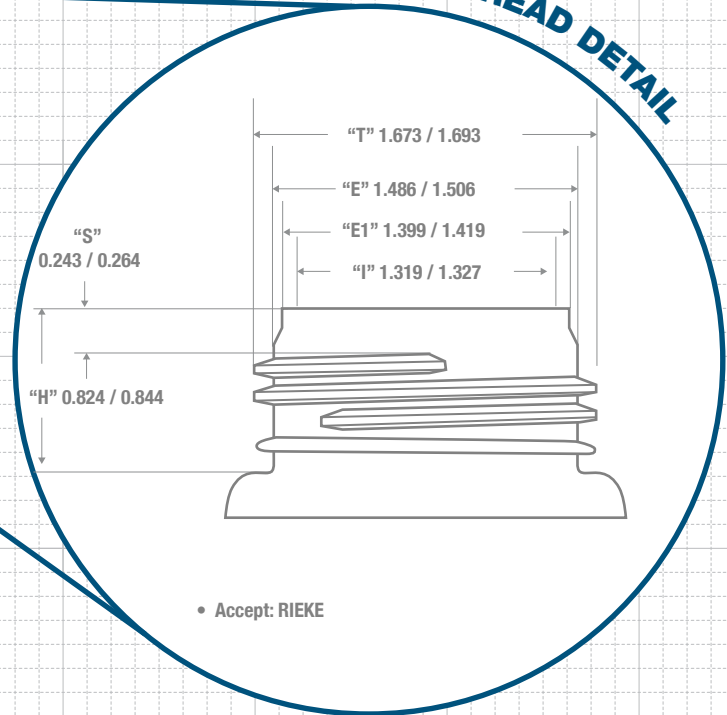

BOTTOM VIEW



PRINTING SPECIFICATIONS: 200 ml CLASSIC FOAMER 43 mm Rieke

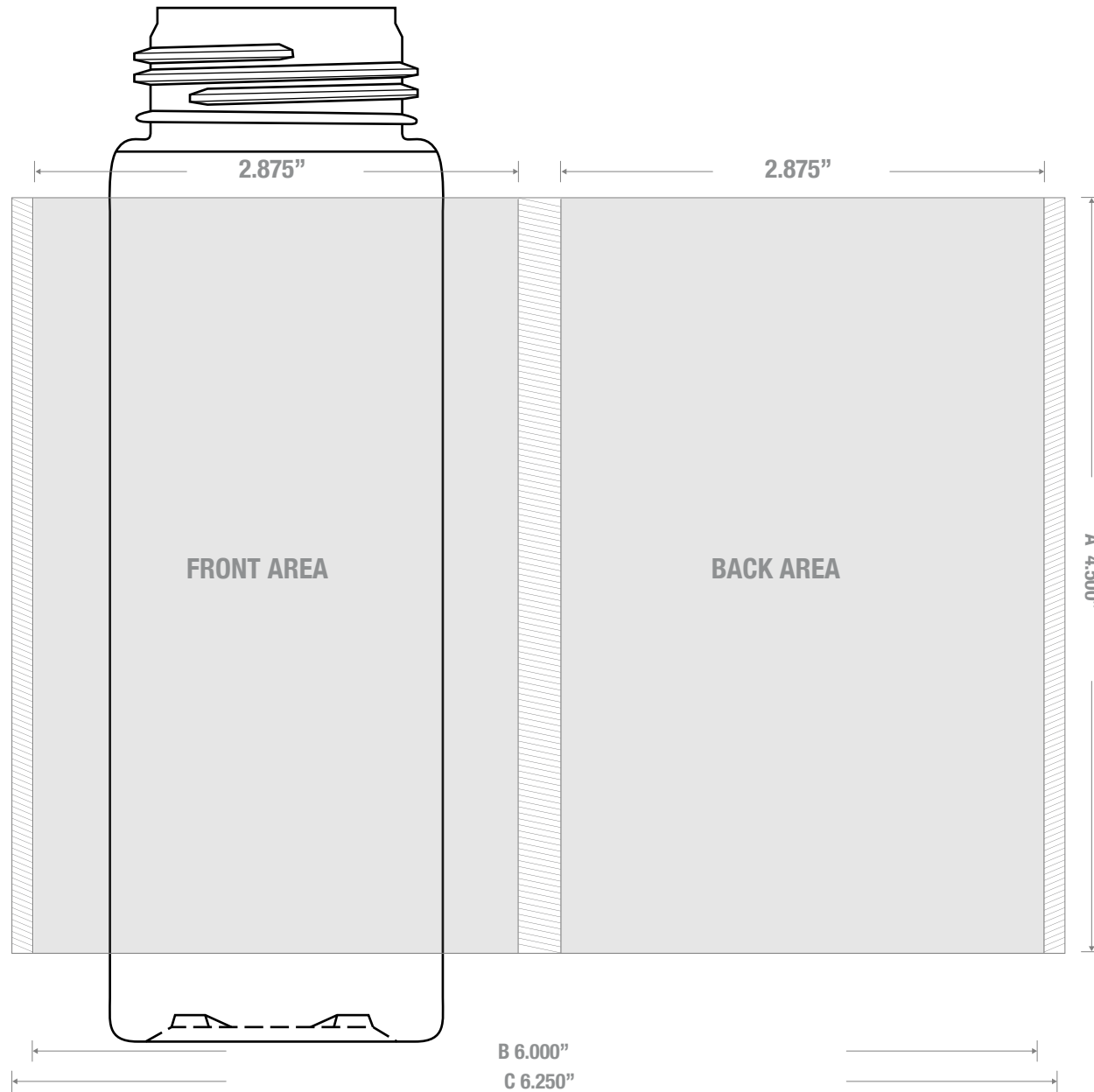

1700 S Hellman Ave, Ontario, California 91761
Phone: (909) 930-3610 | Fax: (909) 930-3640
e-mail: info@classiccontainers.com
www.classiccontainers.com

A - Total Height.
B - Max. Decorating Area.
C - Total bottle circumference.
▨ - Unprintable area.

LABELING SPECIFICATIONS: 200 ml CLASSIC FOAMER 43 mm Rieke

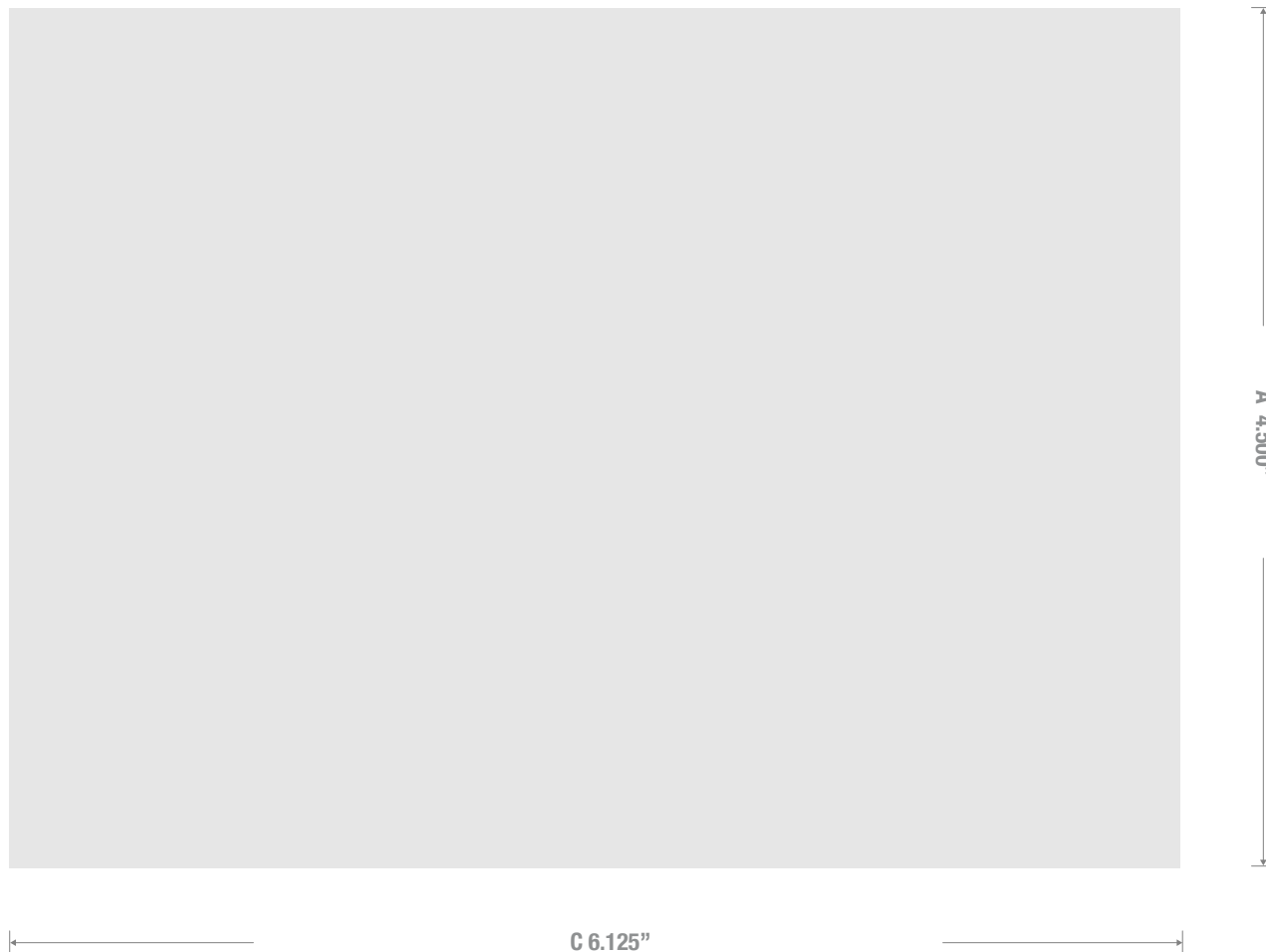

1700 S Hellman Ave, Ontario, California 91761
Phone: (909) 930-3610 | Fax: (909) 930-3640
e-mail: info@classiccontainers.com
www.classiccontainers.com

A - Total Height.
B - Total bottle circumference.