



Drawing:
200 ml Boston Round 24/410

Stock Code:
020000060241700

Manufacturing Process:
Stretch Blow Molding

Overflow Capacity:
209 - 221 ml (7.1 - 7.5 oz)

Gram Weight:
15 ± 1

Neck Finish:
24/410

Base Width (A):
2.200 ± 0.050

Overall Height (B):
4.300 ± 0.050

Max Print Area (Height):
2.625"

Max Print Area (Width):
6.458"

Case Pack: 304

Case Weight (lb): 12.2 ± 0.7

Cases Per Pallet: 25

Box Dimensions:
23 5/8 x 15 9/16 x 17

Stock Material:



CLASSIC CONTAINERS INC
1700 S. Hellman Ave.
Ontario, CA 91761
Phone: 909-930-3610
e-mail: info@classiccontainers.com
www.classiccontainers.com

FRONT VIEW

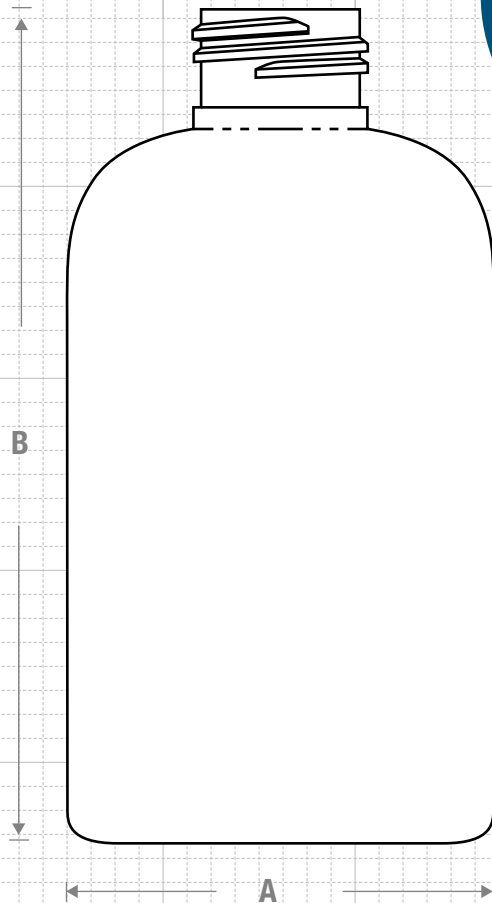

NECK & THREAD DETAIL

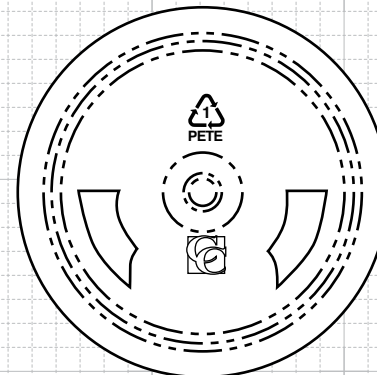
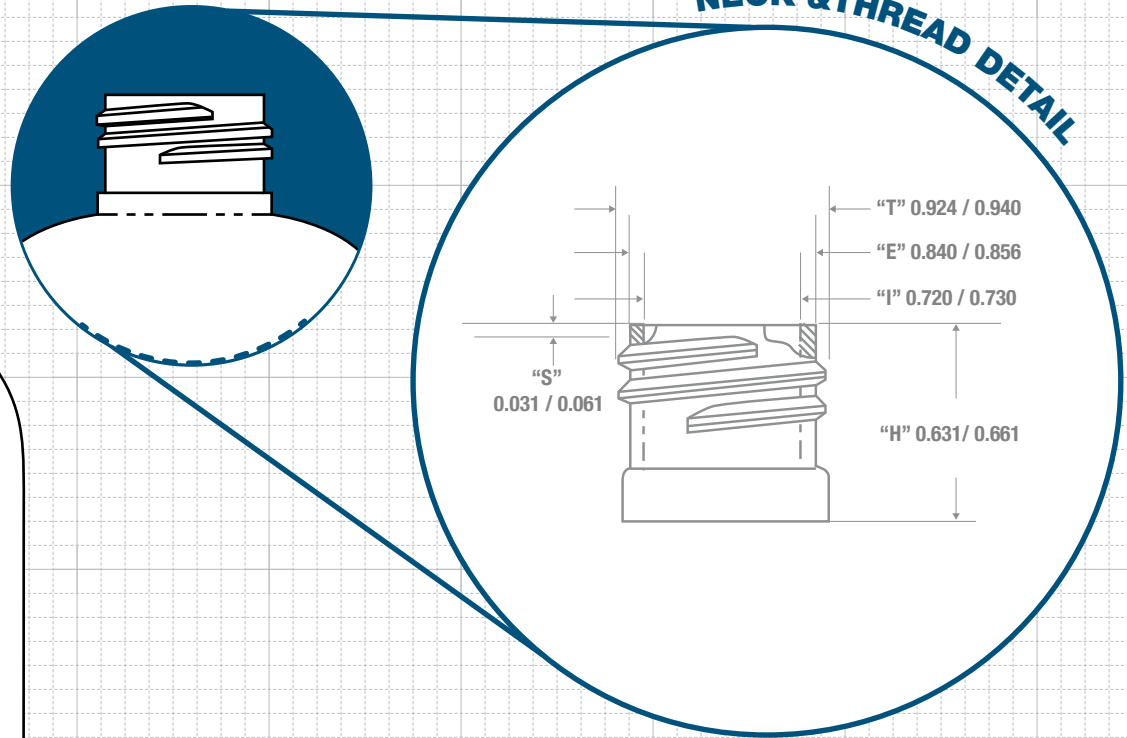

BOTTOM VIEW

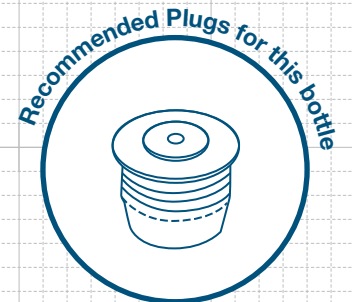

FRICION FIT

PRINTING SPECIFICATIONS: 200 ml BOSTON ROUND 24/410

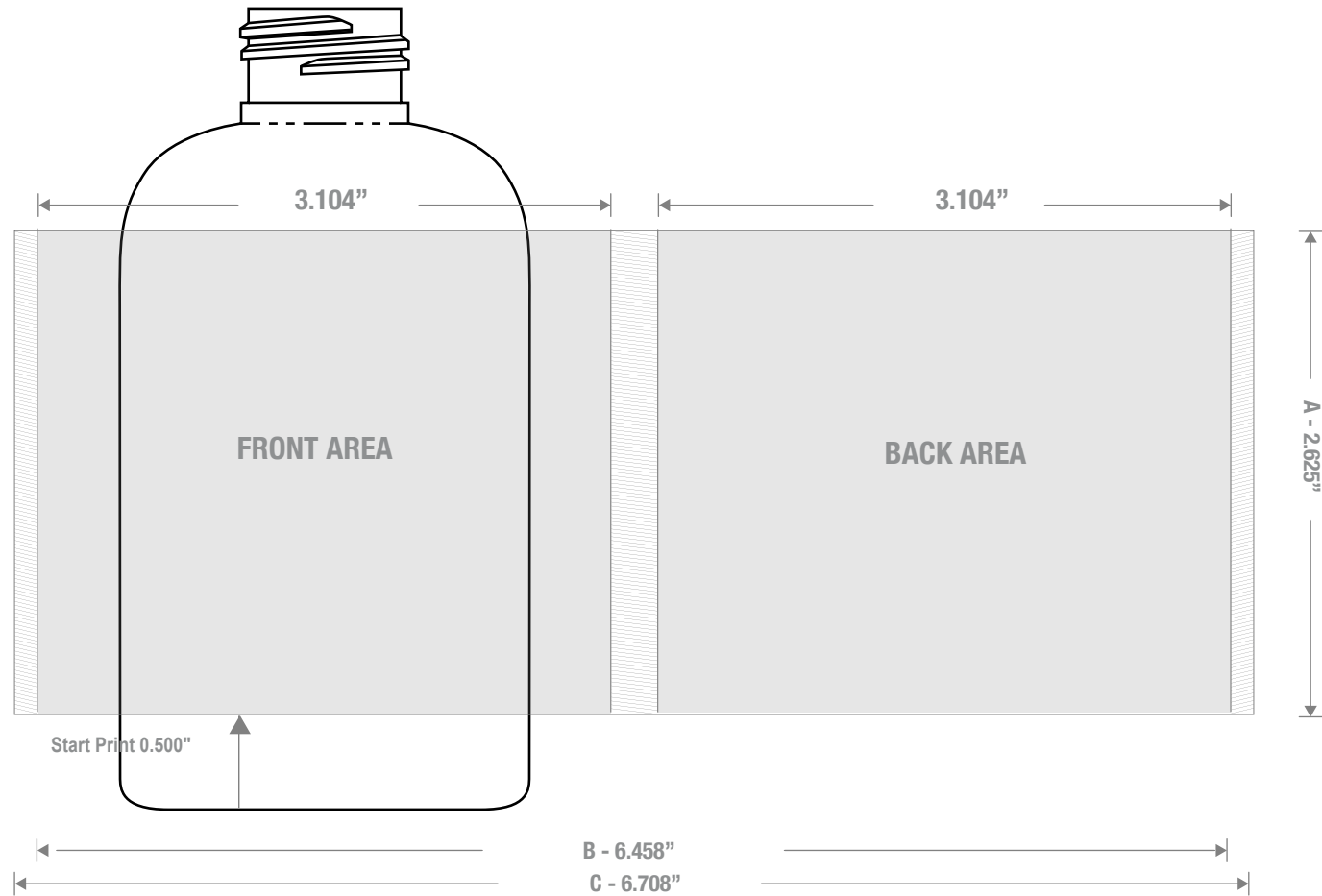

1700 S Hellman Ave, Ontario, California 91761
 Phone: (909) 930-3610 | Fax: (909) 930-3640
 e-mail: info@classiccontainers.com
www.classiccontainers.com

A - Total Height.
B - Max. Decorating Area.
C - Total bottle circumference.
 - Unprintable area.

LABELING SPECIFICATIONS: 200 ml BOSTON ROUND 24/410



1700 S Hellman Ave, Ontario, California 91761
Phone: (909) 930-3610 | Fax: (909) 930-3640
e-mail: info@classiccontainers.com
www.classiccontainers.com

A - Total Height.
B - Max. Decorating Area.