



Drawing:
1 oz Tincture 18/415

Stock Code:
000101400190000

Manufacturing Process:
Extrusion Blow Molding

Overflow Capacity:
36 - 39 ml (1.21 - 1.37 oz)

Gram Weight:
6.5 ± 0.5

Neck Finish:
18/415

Base Width (A):
1.200 ± 0.050

Overall Height (B):
3.138 ± 0.050

Max Print Area (Height):
1.500"

Max Print Area (Width):
3.438"

Case Pack: 1520

Case Weight (lb): 23.9 ± 2.7

Cases Per Pallet: 25

Box Dimensions:
23 5/8 x 15 9/16 x 17

Stock Material:



CLASSIC CONTAINERS INC
1700 S. Hellman Ave.
Ontario, CA 91761
Phone: 909-930-3610
e-mail: info@classiccontainers.com
www.classiccontainers.com

FRONT VIEW

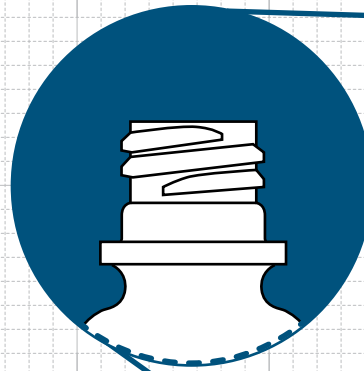
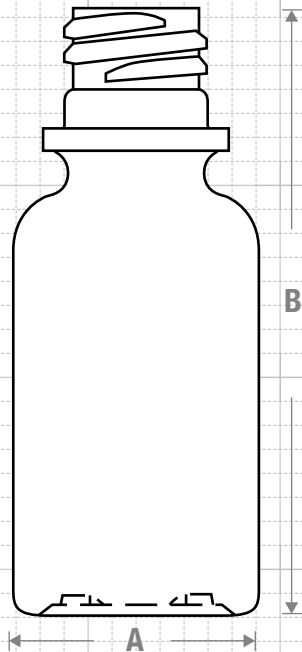

NECK & THREAD DETAIL

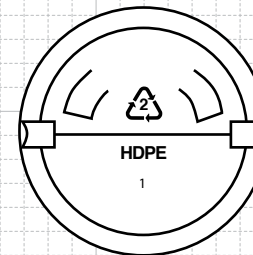
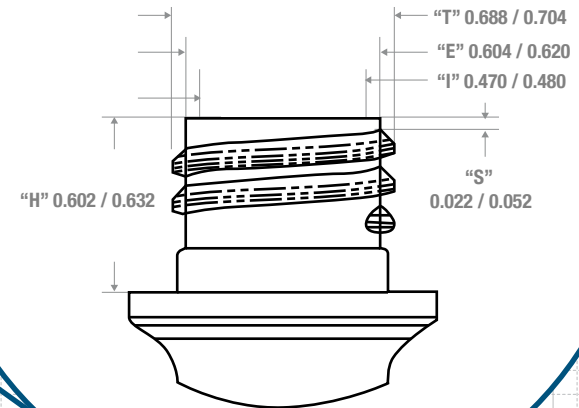

BOTTOM VIEW



PRINTING SPECIFICATIONS: 1 Oz Tincture 18/415

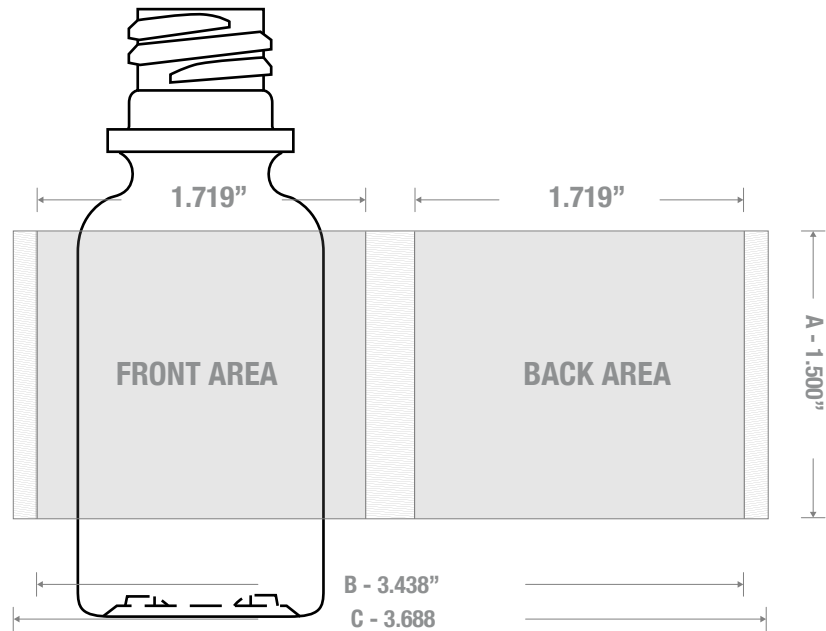

1700 S Hellman Ave, Ontario, California 91761
Phone: (909) 930-3610 | Fax: (909) 930-3640
e-mail: info@classiccontainers.com
www.classiccontainers.com

A - Total Height.
B - Max. Decorating Area.
C - Total bottle circumference.
☐ - Unprintable area.