



Drawing:
**1 oz Imperial Round 20/415
 Mold-2**

Stock Code:
0001000502100M2

Manufacturing Process:
Extrusion Blow Molding

Overflow Capacity:
34- 38.3 ml (1.15 - 1.30 oz)

Gram Weight:
6.0 ± 0.5

Neck Finish:
20/415

Base Width (A):
1.160 ± 0.050

Overall Height (B):
3.150± 0.050

Max Print Area (Height):
1.625"

Max Print Area (Width):
3.437"

Case Pack: **1565**

Case Weight (lb): **22.8 ± 1.7**

Cases Per Pallet: **25**

Box Dimensions:
23 5/8 x15 9/16 x 17

Stock Material:



CLASSIC CONTAINERS INC
 1700 S. Hellman Ave.
 Ontario, CA 91761
 Phone: 909-930-3610
 e-mail: info@classiccontainers.com
www.classiccontainers.com



FRONT VIEW

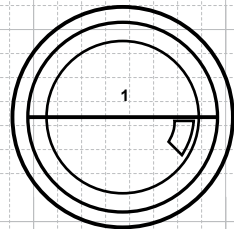
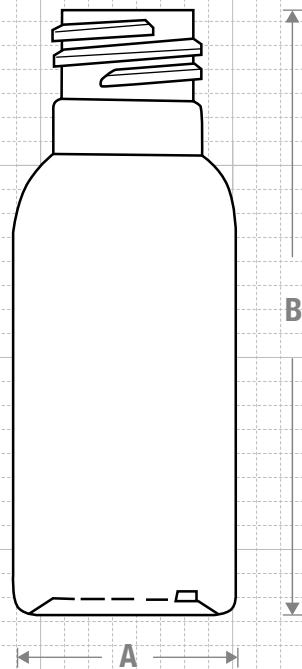

BOTTOM VIEW

NECK & THREAD DETAIL

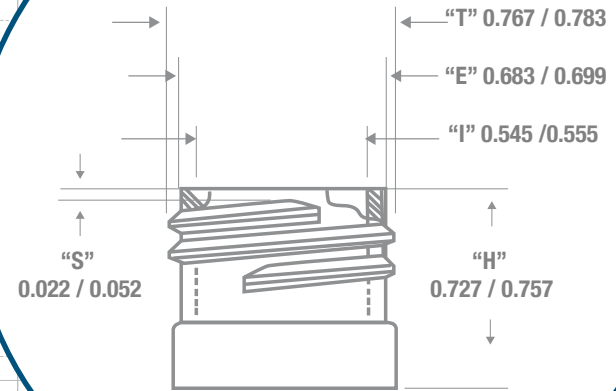

Recommended Plugs for this bottle

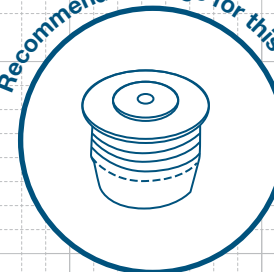

Recommended Plugs for this bottle



FRICTION FIT

PRINTING SPECIFICATIONS: 1 oz IMPERIAL ROUND 20/415 Mold-2

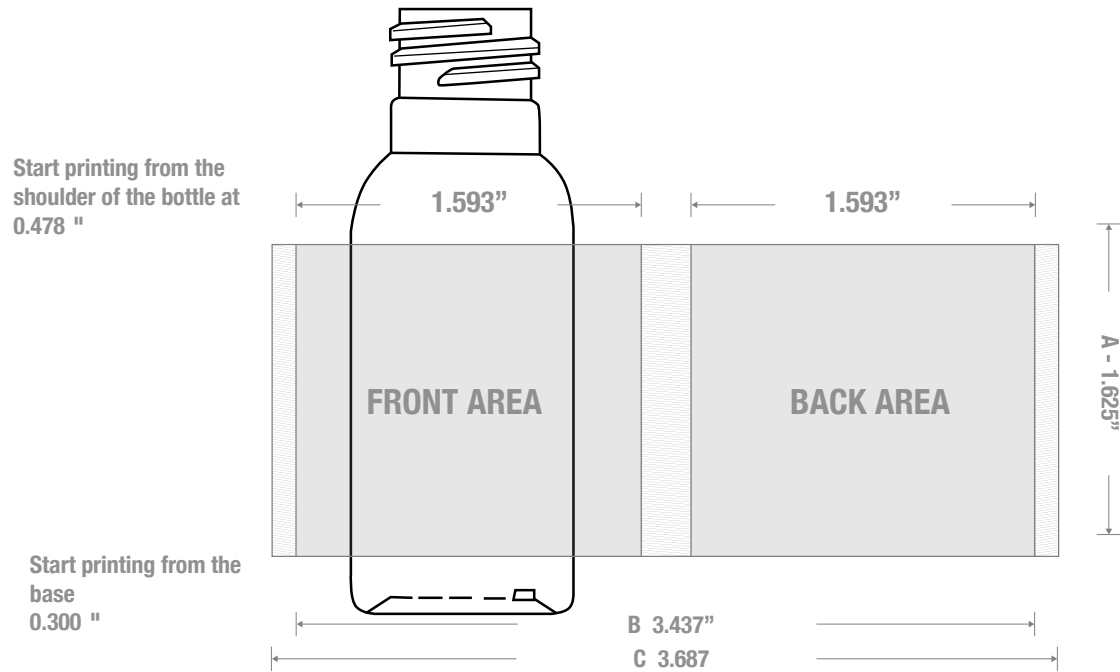

1700 S Hellman Ave, Ontario, California 91761
 Phone: (909) 930-3610 | Fax: (909) 930-3640
 e-mail: info@classiccontainers.com
www.classiccontainers.com

A - Total Height.
B - Max. Decorating Area.
C - Total bottle circumference.
 [Shaded Box] - Unprintable area.

LABELING SPECIFICATIONS: 1 oz IMPERIAL ROUND 20/415 Mold-2

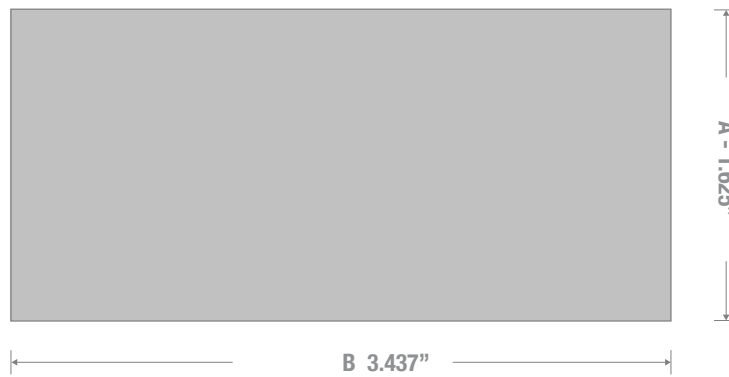

1700 S Hellman Ave, Ontario, California 91761
Phone: (909) 930-3610 | Fax: (909) 930-3640
e-mail: info@classiccontainers.com

A - Total Height.
B - Max. Decorating Area.