



Drawing:
1 oz Imperial Round 20/410

Stock Code:
000100050217000

Manufacturing Process:
Stretch Blow Molding

Overflow Capacity:
35.4 - 40.1ml (1.20 - 1.36 oz)

Gram Weight:
5.5 ± 0.5

Neck Finish:
20/410

Base Width (A):
1.170 ± 0.050

Overall Height (B):
2.840 ± 0.050

Max Print Area (Height):
1.550"

Max Print Area (Width):
3.390"

Case Pack: 1758

Case Weight (lb): 23.4± 1.9

Cases Per Pallet: 25

Box Dimensions:
23 5/8 x 15 9/16 x 17

Stock Material:



FRONT VIEW

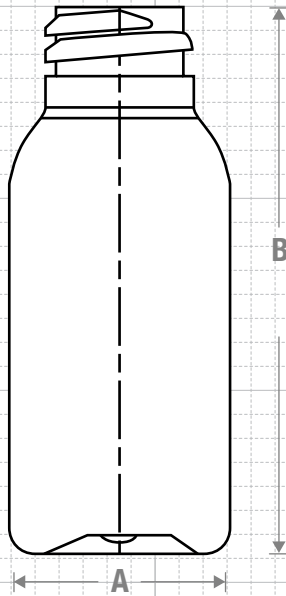

SIDE VIEW

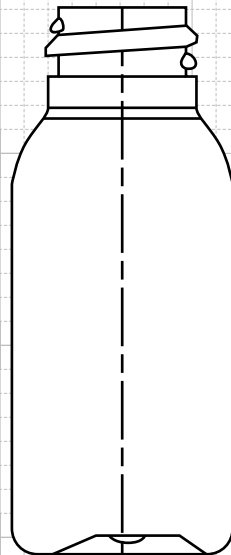

NECK & THREAD DETAIL

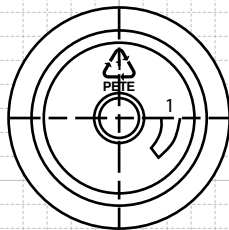
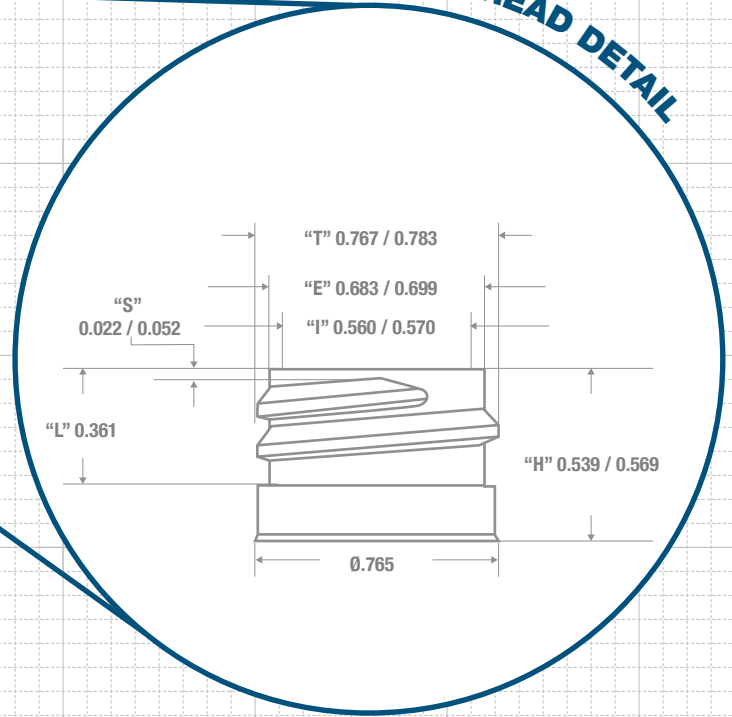
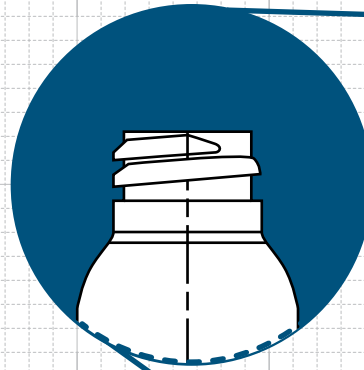

BOTTOM VIEW

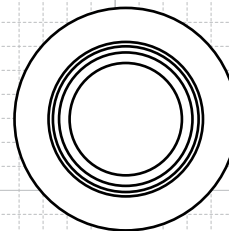

TOP VIEW

Recommended Plugs for this bottle



Recommended Plugs for this bottle



FRICITION FIT

CLASSIC CONTAINERS INC
1700 S. Hellman Ave.
Ontario, CA 91761
Phone: 909-930-3610
e-mail: info@classiccontainers.com
www.classiccontainers.com

PRINTING SPECIFICATIONS: 1 oz IMPERIAL ROUND

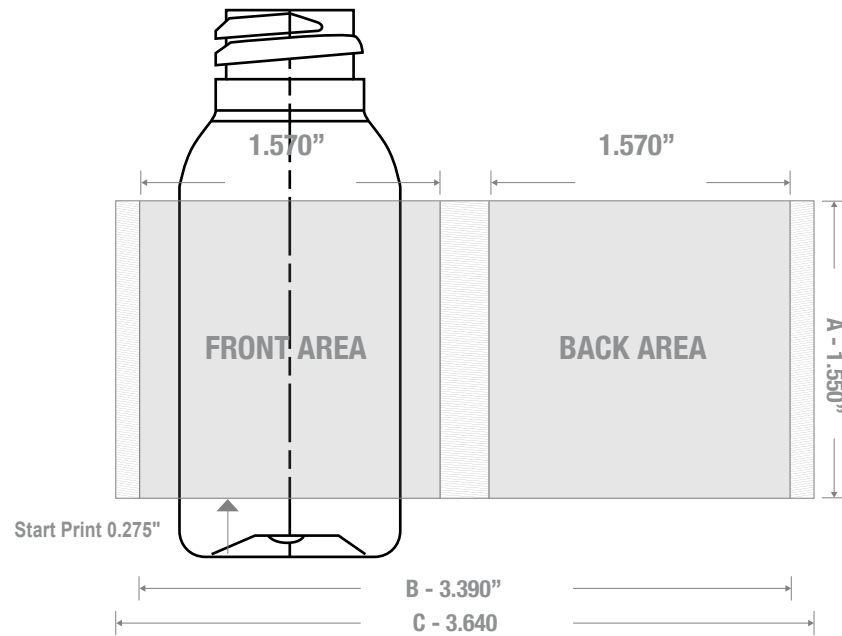

1700 S Hellman Ave, Ontario, California 91761
Phone: (909) 930-3610 | Fax: (909) 930-3640
e-mail: info@classiccontainers.com
www.classiccontainers.com

A - Total Height.
B - Max. Decorating Area.
C - Total bottle circumference.
▨ - Unprintable area.